

PRO Series®

BATTERY HANDLING EQUIPMENT



UNI-TUGGER

OWNER'S MANUAL

OPERATOR'S MANUAL / PARTS MANUAL

PRO SERIES®

BATTERY HANDLING EQUIPMENT

UNI-TUGGER BATTERY HANDLING EQUIPMENT

UTE-XX-24-FM

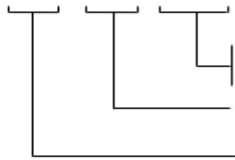

FM-Front Mount

DC Voltage (V)

Compartment Width (30 in; 36 in)

The information contained in the publication is for customer use only.

All rights reserved. Reproduction in any form or by any means, adaptation, translation or other use without the express written permission of Carney Battery Handling is prohibited.

OWNER'S MANUAL OPERATOR'S MANUAL / PARTS MANUAL

PROSERIES®

BATTERY HANDLING SOLUTIONS

EnerSys EMEA Motive Power - Working in partnership with Carney Battery Handling Ltd.

ENERSYS EMEA

EH Europe GmbH
Baarerstrasse 18
6300 Zug
Switzerland

Phone: +41 (0)44 215 74 10 • Fax: +41 (0)44 215 74 11

Email: info@enersys-hawker.com

<http://www.enersys.com>







SYMBOL IDENTIFICATION CHART





	Refer to accompanying documentation.		Refer to Manual.
	Do not operate without all guards and covers in place.		Crush Hazard – Keep Hands Clear.
	Entanglement Hazard – From chain, gear or pulley.		Pinch Point Hazard
	Crush Hazard From Falling Load		Crush Hazard – Keep Feet Clear
	Eye Protection Required		Safety Shoes Required
	Slip Hazard		Heavy Object – Do not exceed recommended load weight.
	Protective Clothing Required		Rubber Gloves Required

BATTERY HANDLING EQUIPMENT

DANGERS, WARNINGS, AND CAUTIONS LABELS

Labels, languages, and symbols shown below may be different than the ones on the unit.
Check the unit for actual labels

DANGER		GEFAHR		DANGER	
	ONLY CERTIFIED OPERATORS SHOULD USE THIS UNIT. WHEN OPERATING, KEEP AREA UNDER LOAD CLEAR.	BETRIEB NUR DURCH AUTORISIERTES PERSONAL. NICHT UNTER DIE LAST TRETEN.	SEULS LES OPERATEURS CERTIFIES PEUVENT UTILISER CET EQUIPEMENT. MAINTIENEZ LES ESPACES SOUS LA CHARGE DEGAGES.		
	DO NOT PULL LOADS IN EXCESS OF 2,300LBS. IT MAY CAUSE INJURY. USE CARE WHEN OPERATING ON AN INCLINE.	DAS ZIEHEN VON LASTEN VON MEHR ALS 1,044 KG (2,300LBS) KANN RÜCKEN-ODER MUSKELVERLETZUNGEN VERURSACHEN, INBESONDERE BEI STEIGUNGEN.	NE TIREZ PAS DES CHARGES EN EXCES DE 2,300 LB / 1,044 KG. DES BLESSURES SONT POSSIBLES. ATTENTION AU TRAVAIL SUR DES INCLINAISONS.		
	DO NOT OPERATE IF YOU ARE IMPAIRED (ILL OR UNDER THE INFLUENCE OF ALCOHOL OR MEDICATION, ERRORS WHEN OPERATING CAN CAUSE HAZARDOUS AND POTENTIALLY LETHAL CONDITIONS.	VERSUCHEN SIE NICHT, DIESES GERÄT ZU BEDIENEN, WENN SIE DURCH KRANKHEIT, MEDIKAMENTE, ALKOHOL ETC BEEINTRÄCHTIGT SIND. FEHLER IM BETRIEB KÖNNEN GEFÄHRLICHE UND POTENZIELL TÖDLICHE FOLGEN HABEN.	N'UTILISEZ AUCUN EQUIPEMENT SI VOUS ETES MALADE OU SOUS L'INFLUENCE DE DROGUES OU DE L'ALCOOL. LES ERREURS DE JUGEMENT PEUVENT ETRE EXTREMEMENT DANGEREUSES ET MEME FATALES. LBL-T60-EGF		
CAUTION		ACHTUNG		ATTENTION	
	TO REDUCE THE RISK OF COLLISION: ENSURE UNIT IS POSITIONED FOR OPTIMAL VISIBILITY.	UM DAS KOLLISIONSRISIKO ZU REDUZIEREN, STELLEN SIE EINE OPTIMALE SICHTBARKEIT SICHER.	AFIN DE REDUIRE LES RISQUES DE COLLISION, ASSUREZ UNE BONNE VISIBILITE.		
	USE CARE WHEN TRANSPORTING LOAD OVER WET FLOOR/SURFACE.	TRANSPORT VON LASTEN AUF NASSEN BODEN FLÄCHEN VORSICHTIG VORGEHEN.	SOYEZ PRUDENT LORSQUE LES PLANCHERS SONT MOUILLES.		
	EYE PROTECTION, SAFETY SHOES AND PROTECTIVE CLOTHING ARE REQUIRED WHEN OPERATING THIS EQUIPMENT.	BEIM BETRIEB DIESES GERÄT, AUGENSCHUTZ, SICHERHEITSSCHUHE UND SCHUTZKLEIDUNG IST ERFORDERLICH.	LUNETTES, CHAUSSURES DE SECURITE, ET VETEMENT DE PROTECTION REQUIS POUR L'OPERATION DE CET EQUIPEMENT. LBL-T60-EGF		

	WARNING	WARNUNG	ATTENTION
	KEEP CLEAR OF MOVING PARTS.	BEWEGLICHE TEILE. ACHTEN SIE AUF HÄNDE UND FINGER.	ÉCRASEMENT! ATTENTION AUX DOIGTS. LBL-T05-EGF
	DANGER	GEFAHR	ATTENTION
	CRUSH HAZARD. KEEP FEET CLEAR.	QUETSCHGEFAHR FÜßE FERN HALTEN.	ÉCRASEMENT! ATTENTION AUX PIEDS. LBL-T10-EGF
	WARNING	WARNUNG	ATTENTION
	PINCH POINT, WATCH YOUR HANDS.	QUETSCHGEFAHR HÄNDE FERN HALTEN.	POINT DE PINCEMENT! ATTENTION AUX MAINS. LBL-T20-EGF
	DANGER	GEFAHR	ATTENTION
	DO NOT OPERATE WITHOUT ALL GUARDS, COVERS AND PANELS IN PLACE.	NUR BETREIBEN, WENN ALLE SCHUTZVORRICHTUNGEN, ABDECKUNGEN UND HAUBEN ANGEBRACHT SIND.	NE PAS UTILISER SANS AVOIR TOUS LES GARDES, COUVERTURES, ET PANNEAUX EN PLACE. LBL-T15-EGF

BATTERY HANDLING EQUIPMENT

VORSICHT **CAUTION** ATTENTION

**DO NOT INSERT FORKS
MORE THAN 305mm**

GABEL NICHT WEITER ALS
305mm EINFÜHREN

NE PAS INSERER LES
FOURCHES PLUS DE 305mm

LBL-T30-EGF

WARNING

IF UNIT FAILS TO OPERATE:
DISCONNECT POWER SOURCE AND
REMOVE TOP COVER.

IF THE BREAKER HAS TRIPPED:
RESET BY PUSHING THE **RED** LEVER UP.

WARNUNG

WENN DAS GERÄT NICHT FUNKTIONIERT
TRENNE SIE DIE STROMQUELLE UND
ENTFERNEN SIE DIE OBERE ABDECKUNG.

WENN DIE BREMSE AUSGELÖST WURDE,
DRÜCKEN SIE DEN ROTEN HEBEL NACH
OBEN.

ATTENTION

SI L'APPAREIL NE FONCTIONNE PAS,
DEBRANCHEZ LA SOURCE D'ALIMENTATION ET
RETIREZ LE COUVERCLE.

SI LE DISJONCTEUR A ETE DECLENCHE,
REACTIVER-LE EN APPUYANT SUR LE LEVIER
ROUGE VERS LE HAUT.

LBL-T30-EGF

WARNING

IF UNIT FAILS TO OPERATE:
DISCONNECT POWER SOURCE AND
REMOVE TOP COVER.

IF THE BREAKER HAS TRIPPED:
RESET BY PUSHING THE **RED** LEVER UP.

WARNUNG

WENN DAS GERÄT NICHT FUNKTIONIERT
TRENNE SIE DIE STROMQUELLE UND
ENTFERNEN SIE DIE OBERE ABDECKUNG.

WENN DIE BREMSE AUSGELÖST WURDE,
DRÜCKEN SIE DEN ROTEN HEBEL NACH
OBEN.

ATTENTION

SI L'APPAREIL NE FONCTIONNE PAS,
DEBRANCHEZ LA SOURCE D'ALIMENTATION ET
RETIREZ LE COUVERCLE.

SI LE DISJONCTEUR A ETE DECLENCHE,
REACTIVER-LE EN APPUYANT SUR LE LEVIER
ROUGE VERS LE HAUT.

LBL-T30-EGF



DANGER GEFAHR



MAGNET HARMFUL TO
PACEMAKER WEARERS.

MAGNETISCH - SCHÄDLICH FÜR
TRÄGER VON
HERZSCHRITTMACHERN.

CHAMP MAGNETIQUE
PEUT-ETRE NOCIF POUR
LES PORTEURS DE
STIMULATEUR CARDIAQUE.

LBL-T55-EGF

BATTERY HANDLING EQUIPMENT

	DANGER CRUSH HAZARD! KEEP BODY CLEAR. <small>LBL-T75-EGF</small>	GEFAHR VORSICHT! NICHT UNTER DIE LAST TRETEN.	DANGER ÉCRASEMENT! GARDER LE CORPS ELOIGNE. <small>LBL-T75-EGF</small>
	WARNING CRUSH HAZARD! KEEP HANDS CLEAR.	WARNUNG QUETSCHGEFAHR! HÄNDE FERN HALTEN.	ADVERTISSEMENT RISQUE D'ÉCRASEMENT! GARDEZ LES MAINS CLAIRES. <small>LBL-T80-EGF</small>
	DANGER HIGH VOLTAGE. QUALIFIED PERSONNEL ONLY.	GEFAHR HOCHSPANNUNG. NUR QUALIFIZIERTES PERSONAL.	ATTENTION HAUTE TENSION UNIQUEMENT AU PERSONNEL QUALIFIE. <small>LBL-T85-EGF</small>



CARNEY

BATTERY HANDLING

BRAMPTON, ONTARIO CANADA LBL-T90-EGF



GABELZIKEN HIER **FORK HERE** FOURCHES ICI





LBL-T05-EGF

BATTERY HANDLING EQUIPMENT

This manual contains important information to help you properly operate and maintain your “**BATTERY TUGGER**” for maximum performance, economy and safety. By practicing correct operating procedures and by carrying out the recommended preventive maintenance suggestions, you will experience long, dependable and safe service.

TABLE OF CONTENTS

TABLE OF CONTENTS.....	7
GENERAL INFORMATION.....	8
Pallet Truck Front Mounting (Figure – 1a).....	9
Fork Truck Front Mounting (Figure – 1b).....	9
UNI-Tugger battery handling equipment / Lift Truck positioning (Figure – 2).....	9
Operating Instructions.....	10
Extraction from the Lift Truck.....	11
UNI-Tugger battery handling equipment Assembly with 24V DC VSJ (Figure – A).....	12
UNI-Tugger battery handling equipment Assembly (Figure – B).....	13
Battery Tugger Assembly (Figure – C).....	14
Battery Tugger Assembly (Figure – D).....	15
Battery Tugger 24V DC VSJ Assembly (Figure – E).....	16
Joystick Control Switch Assembly (Figure – F).....	17
Electrical Schematic 24V VSJ Control (Figure –3.1).....	18
Electrical Schematic 24V Linear Actuators (Figure –3.2).....	19
Battery Tugger Quick Clamp (Figure – 4).....	20
Battery Tugger Quick Clamp (Figure – 4.1).....	21
Electromagnet Maintenance (Figure – 6).....	22
Drive Mechanism Maintenance (Figure – 7).....	23
Slider Strip Maintenance (Figure – 8).....	24
STATEMENT OF WARRANTY.....	26
Pacemaker and Magnet information.....	27
HOW TO PLACE AN ORDER FOR PARTS.....	28

GENERAL INFORMATION

Congratulations on purchasing a new “**UNI-TUGGER**” battery handling equipment. With the proper care and regular maintenance you will receive years of trouble free service.

If you require technical support or other repair services, or if you are ordering replacement parts, please provide us the following information.

Model #	
Serial #	
Customer	
Date in Service	

WARNING

**OPERATING TUGGER WITH LOW VOLTAGE
WILL PREMATURELY CAUSE MOTOR BRUSHES TO FAIL.
(THIS WILL NOT BE COVERED UNDER WARRANTY)**

Note:

**If your Tugger is equipped with an emergency stop button and it is activated, you must wait 20 seconds before pulling the button back up
(This is required for the controller to re-boot itself)**

Pallet Truck Front Mounting (Figure – 1a)

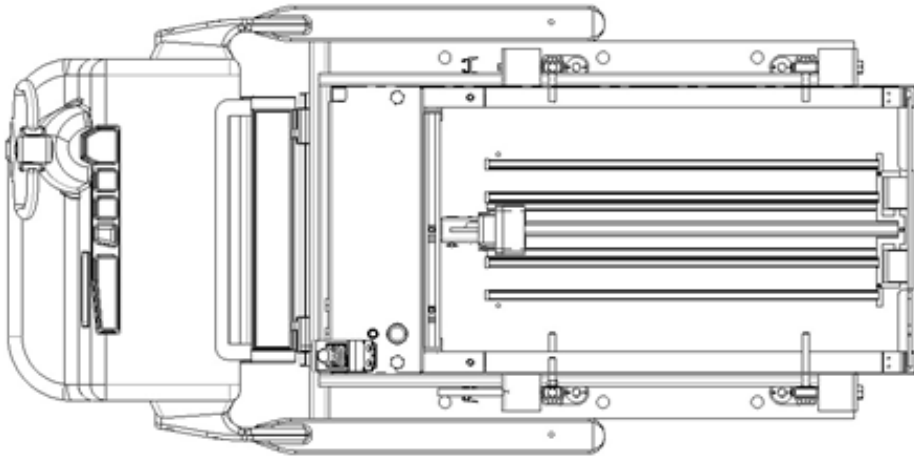

Fork Truck Front Mounting (Figure – 1b)

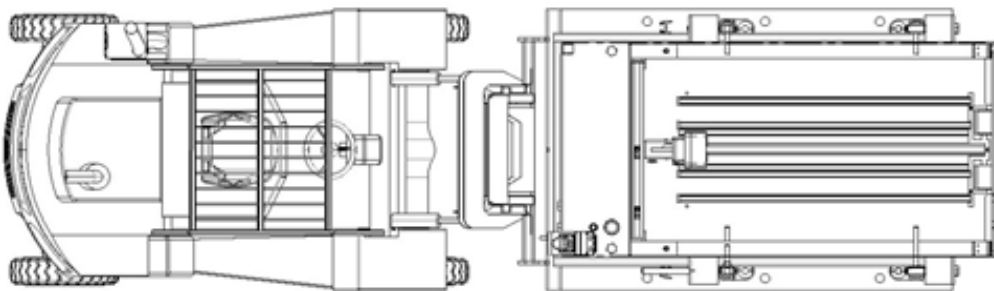

**UNI-Tugger / Lift Truck positioning (Figure – 2)
Example Showing Extraction Using Pallet Truck**

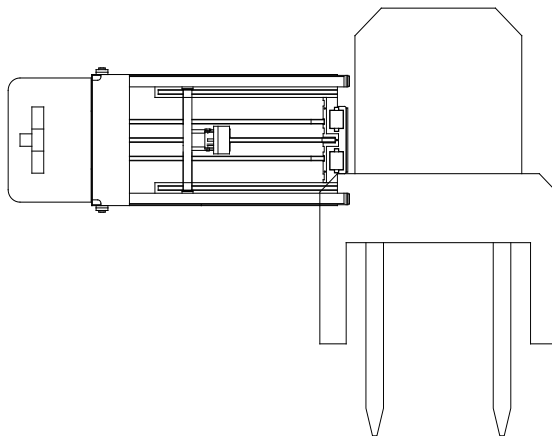

OPERATING INSTRUCTIONS

UNI -Tugger Battery Handling Equipment

Description:

The UNI Tugger battery handling equipment is a non-propelled, electrically powered battery changer that is designed for medium volume applications and all sizes of batteries, such as those found in reach trucks, pallet trucks and 3 & 4 wheel counter-balance trucks.

Before operating the “UNI-TUGGER” battery handling equipment it must be mounted onto a mobile lift truck or pallet truck as shown in figure #1a, or b. It is important that the operator thoroughly review and understand the proper Safety Procedures and Instructions as outlined in this Owner’s Manual and the Owner’s Manual for the mobile truck. It is also important that the “UNI-TUGGER” battery handling equipment be secured to the mobile lifting truck, either bolted permanently or “Quick Clamp” (see Battery Tugger Quick Clamp (Figure – 4) on page 19). Fastening is recommended however fastening can be quick release to allow the host truck to be used in regular operations.

All operators must be trained or certified (if required) in the use of the “UNI-TUGGER” battery handling equipment.



Safety shoes, safety glasses and protective clothing are mandatory in Battery Rooms. Be sure to wear them at all times. Rubber gloves, rubber aprons and full face shields are required when washing and servicing forklift batteries. Always use **caution** and common sense.

Preparation:

1. Park the lift truck in a perpendicular position adjacent to the “UNI-TUGGER” battery handling equipment (Fig. 2, page 8).
2. Prepare the lift truck for battery removal as follows:
 - Lower the forks until they sit flat on the floor.
 - Engage the parking brake.
 - Remove any protective covers.
 - Unplug the battery and position the connector plug And cable so as to prevent snagging or pinching during the battery removal process.
 - Remove the battery retaining gate.

Extraction from the Lift Truck



1. Position the UNI-Tugger battery handling equipment in front of the battery compartment and lower the unit so the front rollers are approximately ½" below the bottom of the battery to be removed.



2. Power the magnet out until it contacts the battery to be removed. Then turn on the magnet toggle switch. Power the magnet back to pull the battery out, until it is just over the large black entry rollers on the UNI-Tugger battery handling equipment.



3. Raise the UNI-Tugger battery handling equipment using the forklift controls until the rollers support the weight of the battery and continue to pull the battery all the way into the UNI-Tugger battery handling equipment.



4. Drive the forklift to an appropriate empty roller stand.



5. Raise or lower the UNI-Tugger battery handling equipment to the roller stand height, then power the magnet to push the battery out onto the roller stand.

Insertion into the Lift Truck:

1. Raise the UNI-Tugger battery handling equipment using the mobile lifting truck controls and/or using linear actuator controls to the roller stand level and retrieve the charged battery.

2. Position the UNI-Tugger battery handling equipment in front of the lift truck battery compartment, and then raise or lower the battery to be **just slightly above** (approx. ½") the level of the lift truck's roller or slider bed.

3. Power the magnet and battery as far as it will go into the lift truck. If using a powered pallet truck, make sure the pallet jack handle is in the vertical position, i.e. brakes are on.

Conclusion:



1. Drive the **"UNI-TUGGER"** battery handling equipment away from the lift truck and park it in a safe location.

2. Check the discharged battery, connect the cables and turn on the charger.

3. Prepare the lift truck for operation as follows:

- **Install the battery retaining gate**
- **Plug in the battery**
- **Install the protective covers**
- **Check the battery indicator gauge**

NOTE: The activation of the controls for the magnet bridge arm (forward/reverse) and the lift up/down can only occur with the simultaneous activation of the two-handed operation button that is mounted next to the emergency stop. The magnet on/off control does not require the activation of the two-handed operation button.

UNI-Tugger Battery Handling Equipment Assembly with 24V DC VSJ (Figure – A)

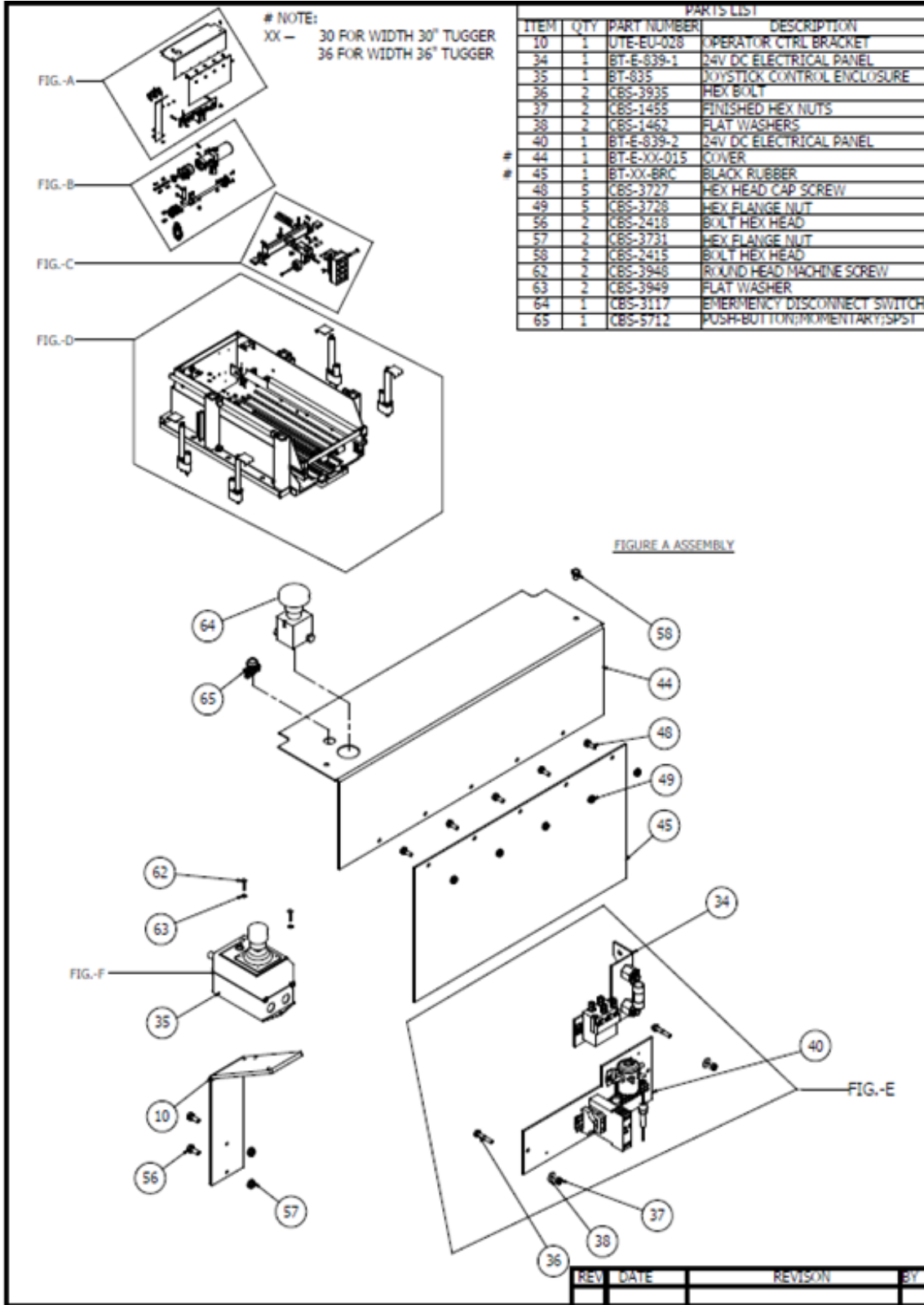

UNI-Tugger Battery Handling Equipment Assembly (Figure – B)

NOTE:
XX- 30 FOR WIDTH 30" TUGGER
36 FOR WIDTH 36" TUGGER

ITEM #	QTY	PART NUMBER	DESCRIPTION
7	1	BT-E-XX-011	Bridge Drive Shaft
8	1	CBS-127	Bearing
9	3	CBS-126	Bearing *
13	3	CBS-364	Sprocket *
15	1	CBS-3748	Motor
21	1	CBS-4388	Sprocket *
30	12	CBS-2474	Hex Bolt *
31	2	CBS-2449	Hex Bolt
32	14	CBS-3722	Large Hex Hange Nut
33	1	CBS-3705	Reducer
47	1	CBS-360-27	Chain *
48	1	CBS-361	Offset Link *
55	4	CBS-3782	Hex Head Bolt
56	4	CBS-1142	Lock Washer
57	8	CBS-1143	Flat Washer
58	4	CBS-1570	Hex Nut
59	2	CBS-109	Double Split Lock Collar
60	1		Keystock 1/4x2-1/4 *
61	1		Keystock 1/4x1-1/4 *
62	1	CBS-4320	Hex Bolt
63	1	CBS-4321	Hex Jam Nut
64	1	CBS-2255	Hex Head Cap Screw
65	1	CBS-3714	Lock Washer
66	1	CBS-3853	Fender Washer
69	1	BTE-SPA-001	Spacer 2L-3/4x2L-1/4x7/16

* : RECOMMENDED SPARE PARTS

FIGURE B ASSEMBLY

REV	DATE	REVISION	BY

Battery Tugger Assembly (Figure – C)

NOTE:
XX – 30 FOR WIDTH 30" TUGGER
36 FOR WIDTH 36" TUGGER

PARTS LIST			
ITEM	QTY	PART NUMBER	DESCRIPTION
16	1	BT-XX-102-W	TUGGER BRIDGE WELDMENT
17	1	BT-522-A	MAGNET PIN WELDMENT
18	2	CBS-1330	PIN
19	1	BT-522-B	PIN WELDMENT
20	1	CBS-2005	ZERK AXLE
22	1	CBS-1252	SPRING *
23	1	MAG-100_1	MAGNET (8 POLES)
24	1	CBS-1312	SET SCREW
25	5	CBS-3721	HEX CAP SCREW
26	1	BT-MAG-505	ELECTRICAL BRACKET
50	1	CBS-511	MAGNET CURLY CORD *
53	8	CBS-3730	HEX BOLT
54	1	BT-101-6-W	MAGNET ARM 6" LONG
		BT-101-8-W	MAGNET ARM 8" LONG
55	1	CBS-3907	NYLOCK HEX NUT
56	1	CBS-2004	WHEEL *
57	1	CBS-2006	SPANNER DRILLED
58	2	BT-518	SLIDE PAD *
59	2	CBS-3727	HEX HEAD CAP SCREW
60	2	CBS-3734	LOCK WASHER
61	2	CBS-1462	FLAT WASHER
62	2	CBS-1334	DOUBLE TUBE WIRE CLAMP

* : RECOMMENDED SPARE PARTS

FIGURE-C ASSEMBLY

DRAWN BY: M.W. DATE: July 6, 2012

Battery Tugger Assembly (Figure – D)

NOTE:
XX – 30 FOR WIDTH 30" TUGGER
36 FOR WIDTH 36" TUGGER

ITEM #	QTY	PART NUMBER	DESCRIPTION
1	1	BT-E-XX	TUGGER UPPER PLATFORM WELDMENT
2	1	BT-E-XX	TUGGER LOWER PLATFORM WELDMENT
3	2	BT-810	TUGGER BUMPER *
4	1	BT-825	TUGGER BUMPER LOWER FRONT
5	2	BT-597	ROLLER SHAFT *
6	2	BT-596	ROLLER *
7	4	CBS-5658	LINEAR ACTUATOR *
8	4	JTE-EU-019	STATIONARY COVER
11	2	BT-574	CHAIN GUARD
14	6	BT-510	SLIDER TRIP 48" LG *
15	1	BT-60X	SLIDER TRIP 48" LG *
19	2	CBS-3908	HEX JAM NUT
23	2	BT-103	SPROCKET YOKE
24	2	BT-105	PIN *
25	4	CBS-258	RETAINING RING *
26	2	CBS-363	SPROCKET *
27	6	CBS-1498	FLAT SOCKET CAP SCREW
28	3	CBS-3718	HEX SOCK FLAT UNY. HEAD SCREW
29	2	CBS-3172	FLAT SOCKET CAP SCREW
30	12	CBS-2474	BOLT HEX
31	1	BT-848-B1	BOLT ON SLIDER TOP
32	8	CBS-3722	LARGE HEX FLANGE NUT
41	4	CBS-3011	FLAT WASHER
42	4	CBS-3714	LOCK WASHER
43	4	CBS-3726	HEX BOLT
46	2	CBS-360-112	CHAIN *
47	2	CBS-362	LINK *
48	2	JTE-EU-030	SPROCKET GUARD
64	2	BT-833	MICRO SWITCH MTG. PLATE
65	2	CBS-3615	FLEXIBLE ROD MICRO SWITCH *
66	8	CBS-3740	HEX NUT NYLOCK
67	4	CBS-3741	SOCKET HEAD SCREW
68	4	CBS-3742	SOCKET HEAD SCREW
69	16	JTE-EU-029	BEARING PAD

* : RECOMMENDED SPARE PARTS

FIGURE D ASSEMBLY

DRAWN BY: RM DATE: 1/19/22

Battery Tugger 24V DC VSJ Assembly (Figure – E)

24V CURTIS CONTROLLER JOYSTICK VARIABLE SPEED ASSEMBLY
BTE-854-4-VSJR-1

PART LIST			
ITEM	QTY	PART NUMBER	DESCRIPTION
1	1	CBS-4106-VSJ	Motor Controller
2	1	BT-E-24-035-R1	Contactors Bracket
3	1	CBS-3736	Motor Contactor
4	3	CBS-2102	Stand Off
5	1	CBS-4375	60A Circuit Breaker *
6	4	CBS-2436	Hex Bolt
7	4	CBS-1494	Lock Washer
8	2	CBS-3894	Flat Washer
9	2	CBS-3983	Flat Washer
10	2	CBS-3982	Machine Screw
11	2	CBS-1522	Machine Screw
12	2	CBS-3887	Lock Nut
13	1	BTE-VSJR-G2	18-70 Pvc CABLE (4Fr) P03 VSJ
14	4	CBS-719	Diode
15	1	BT-E-24-016	MOUNTING RATE
16	1	CBS-291	CONTACTOR 24VDC *
17	1	CBS-5298	TIMER RELAY
18	1	CBS-2100	TERMINAL STRIP
19	2	CBS-1840	FUSE HOLDER
20	1	CBS-1164	DIN RAIL
21	2	CBS-411	TERMINAL BLOCK
22	1	CBS-1413	TERMINAL END BLOCK
23	2	CBS-3986	MACHINE SCREW
24	1	CBS-1842	15A FUSE *
25	1	CBS-2103	6A FUSE *
26	1	CBS-469	Terminal Block End Cap
27	2	CBS-3889	Hex Bolt
28	2	CBS-2399	Hex Nylon Locknut

* : RECOMMENDED SPARE PARTS

24 V JOYSTICK VARIABLE SPEED ELECTRICAL PANEL ASSEMBLY
BTE-840

R3	Item 17 from CBS-1216 to CBS-5298	JAN 2021	J.S.
R1	Change 50A fuse to 60A Circuit Breaker	3 Nov. 2014	J.S.
Rev.	Description	Date	Approved

DRAWN BY:	M.W.	DATE:	Nov.04,2014
-----------	------	-------	-------------

Joystick Control Switch Assembly (Figure – F)

PARTS LIST			
ITEM	QTY	PART NUMBER	DESCRIPTION
1	1	BTE-VSJ-4095	CONTROL PANEL ENCLOSURE (2 PCS)
2	1	CBS-489 *	TOGGLE SWITCH
3	1	CBS-2696 *	JOY STICK
4	1	BTE-VSJ-C-1	18-10C SOOW CABLE CABTIRE 4FT
5	1	CBS-2086 *	IN LINE CONNECT 5 PIN
6	1	CBS-2113	STR. CONECTOR 2 SCREW
7	1	CBS-1823	LOCK NUT
8	1	LBL-177	LABEL
9	2	CBS-5104/5466	BASE/CONTACTOR BLOCK
10	2	CBS-XXXX	PUSH BUTTON

* : RECOMMENDED SPARE PARTS

CUSTOMER ORDER PARTS:
CAN REFERENCE BTE-835

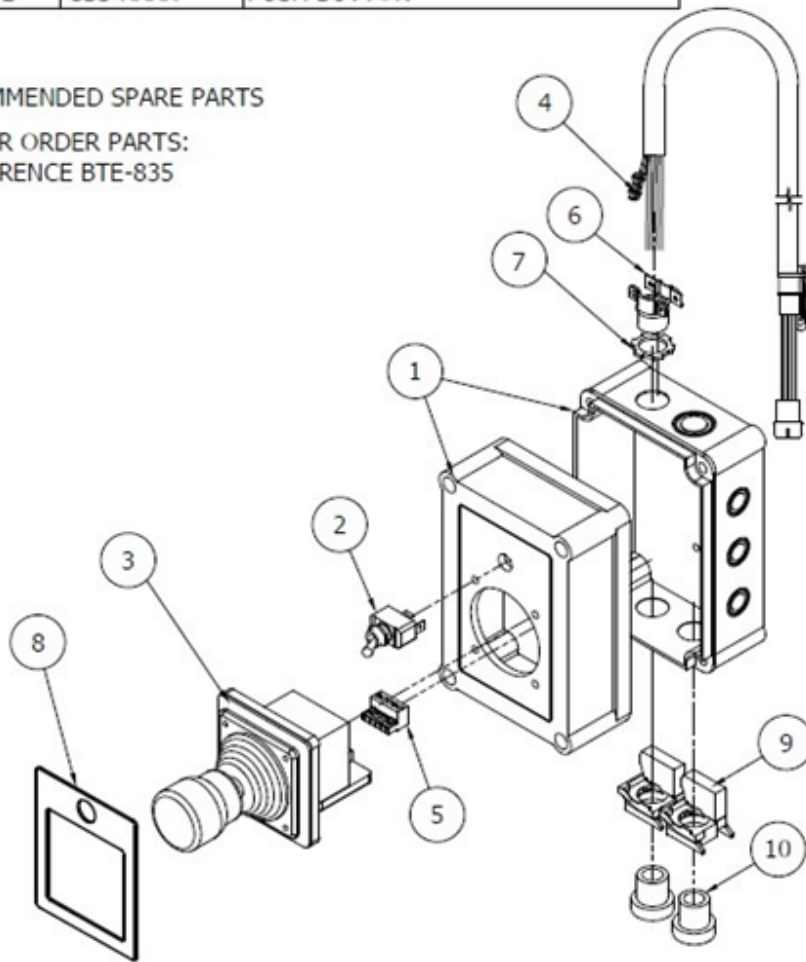

TITLE:	JOYSTICK CONTROL ENCLOSURE WITH SOOW CABLE 18-10C			
DRAWN BY:	RM	DATE:	1/18/22	DWG NO. BTE-835

Electrical Schematic 24V VSJ Control (Figure –3.1)

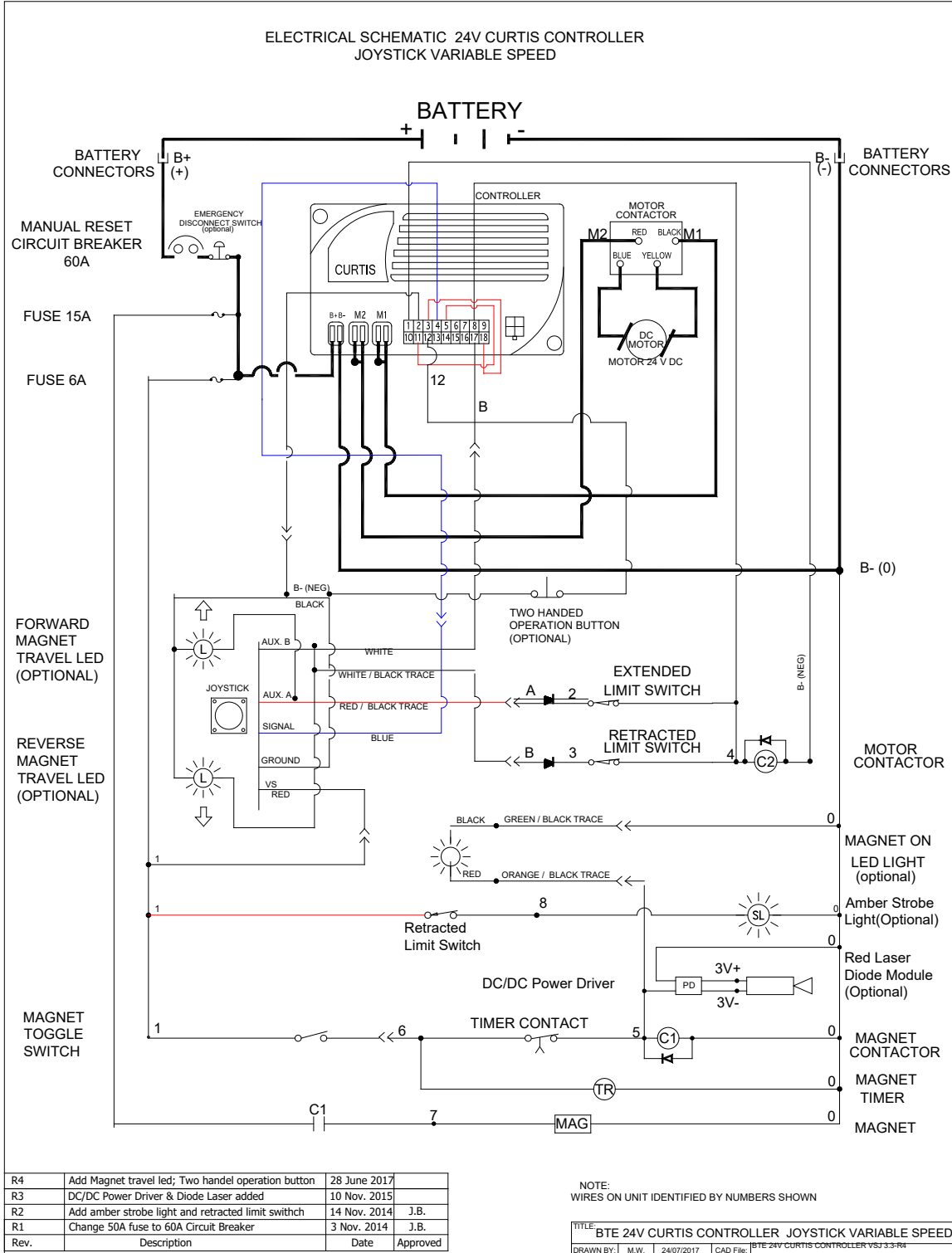

Electrical Schematic 24V Linear Actuators (Figure –3.2)

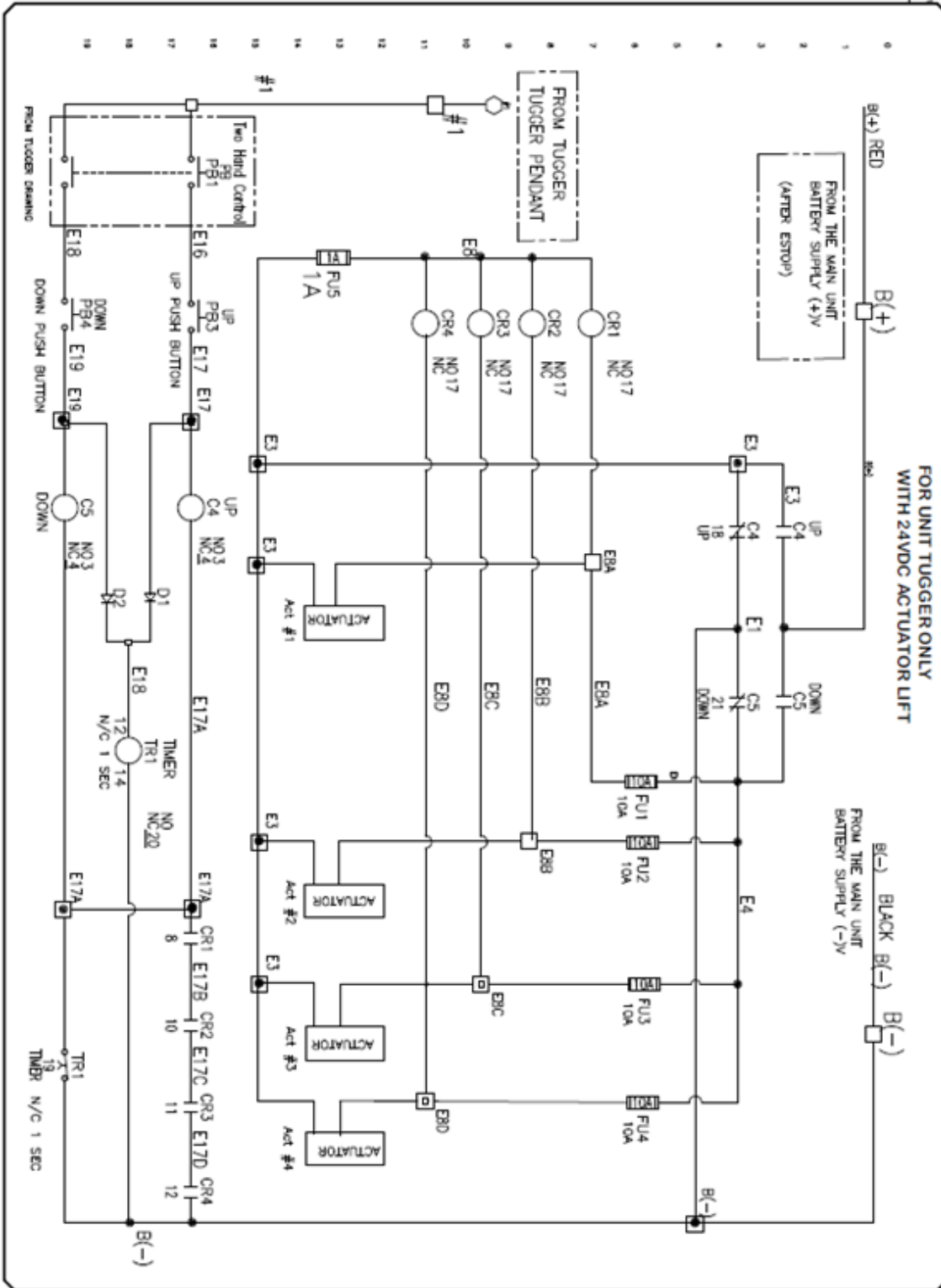

**Battery Tugger Quick Clamp (Figure – 4)
BT-QC**

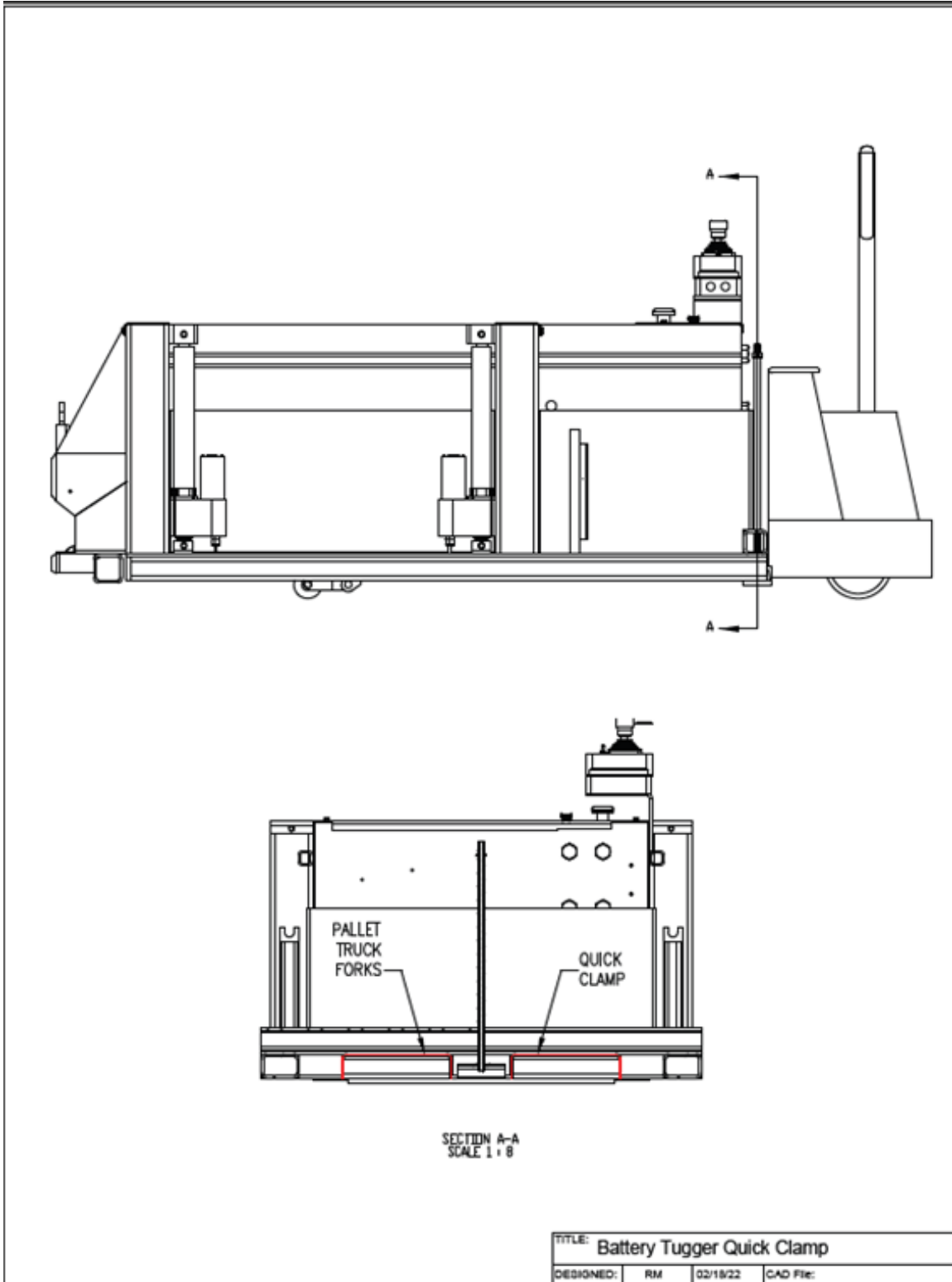

Battery Tugger Quick Clamp (Figure – 4.1)

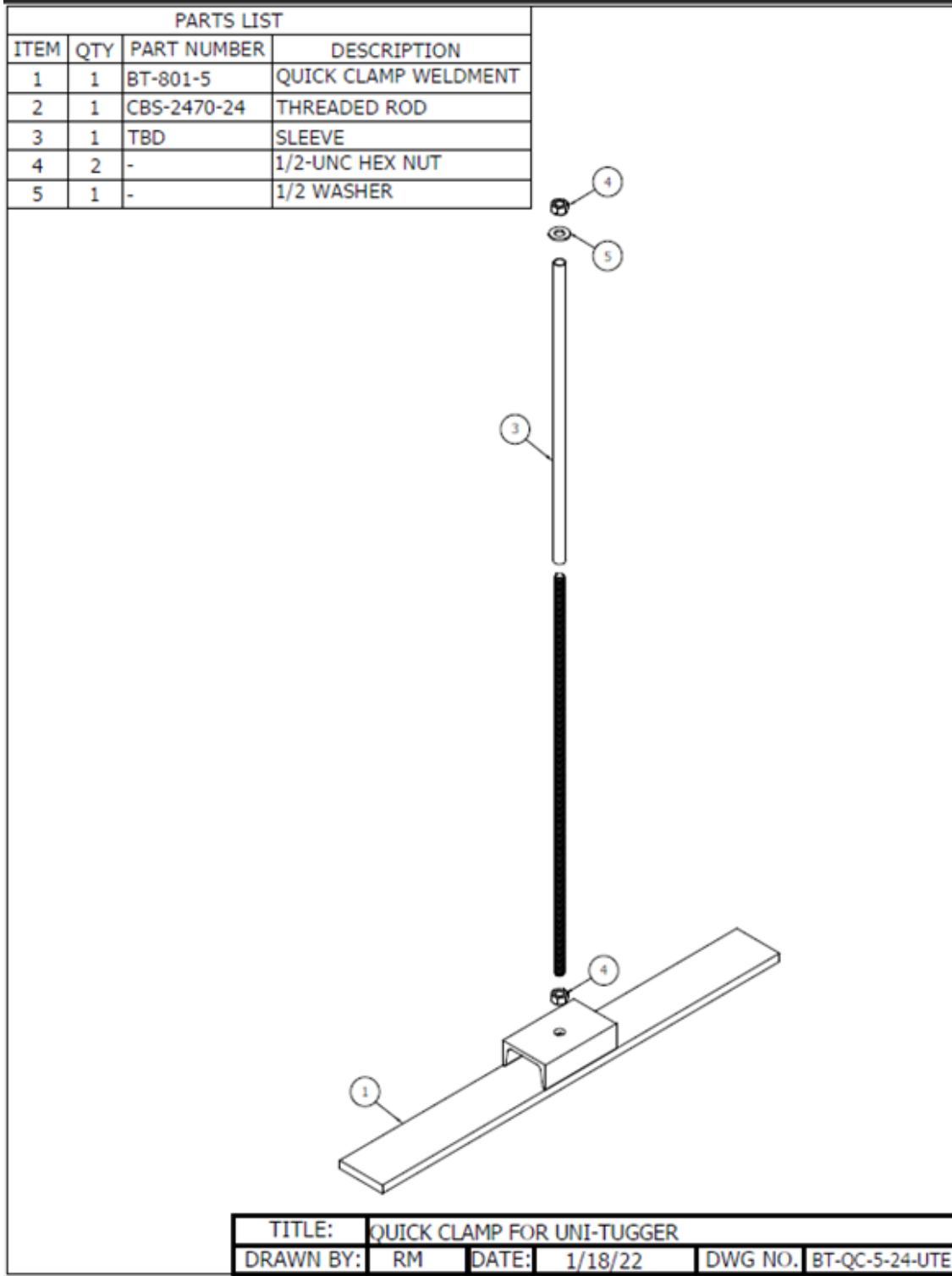

Electromagnet Maintenance (Figure – 6)

Electromagnets require very little maintenance to provide a long useful life. Daily use of a shop towel to wipe the magnet face free of debris, grease and oil or other foreign matter will ensure years of service life and thousands of safe operations.

The pulling capacity is greatly reduced when the face of the magnet is dirty. Use care when handling the magnet so as not to nick or mar the pulling surface. If the face is heavily worn, lightly surface grind a few thousandths off the face to clean up the pulling surface.

Never try to remove the electrical wires mounted in the magnet. Should you do this you will destroy the magnet and it will require rebuilding or replacement.

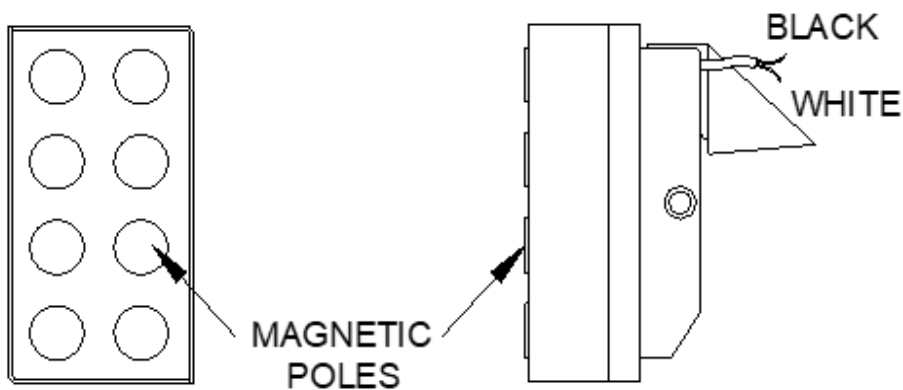

TITLE Electromagnet Maintenance			
DESIGNED:	MJS	04/03/02	CAD FILE: b1manualdrawing.dwg

Drive Mechanism Maintenance (Figure – 7)

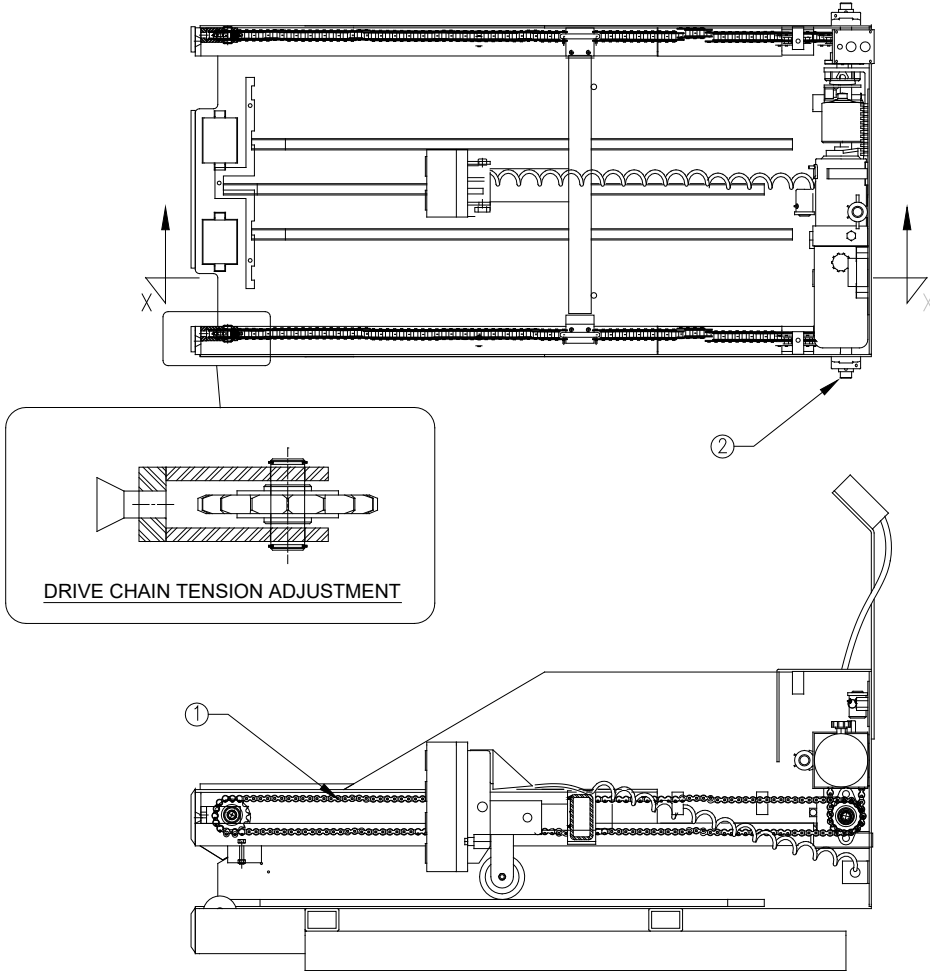

Item	Grease Points	# Of Points	SECTION "A-A" Lubricant	Part Number
1	Drive Chain	3	Spray into container use brush to apply monthly SCHAEFFERS 200	CBS-3597
2	Bearing	2	'Rotanium' / LOWSON Blue grease or equivalent 2 Months. P-35000	CBS-1208
	Cleaner		WD-40 (Local purchase)	
	Antiseize		Loctite silver grade (76759)	CBS-4236

ATTENTION: Check monthly and tighten any bolts that have become loose.
Check the drive chain tension. There should be no more than 1/2" of deflection.
See 'Drive Chain Tension Adjustment' inset.
If excessively slack, remove one full link or 1/2 link and reset tension.
If chain is badly worn or stretched, replace it.

TITLE: Drive Mechanism Maintenance			
DESIGNED:	MJS	04/03/02	CAD File: btmanualdrawings.dwg

Electromagnet Maintenance (Figure – 6)

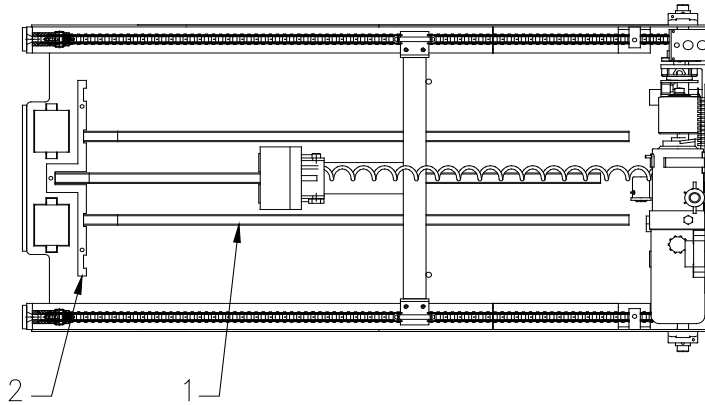

The three (3) slider strips (Item 1) on the floor of the **"BATTERY TUGGER"** will require regular maintenance to provide long and useful service (weekly).

Wipe the top of the slider strips to remove debris, grease, oil and any other foreign material. This will reduce the friction and ensure a long service life with thousands of safe operations.

If the slider strips are heavily worn, replace them. To do this remove front slider stop (item 2) and slide the plastic Slider Strip out. Slide the new Slider Strip into the Slider Strip Channel and replace front slider stop (item 2).

TITLE: Slider Strip Maintenance			
DESIGNED:	MJS	04/03/02	CAD File: btmanualdrawings.dwg



CARNEY BATTERY HANDLING LTD.

SAFETY FEATURES AND RESPONSIBILITIES FOR CARNEY BATTERY HANDLING EQUIPMENT

To whom it may concern:

Carney Battery Handling has engineered and designed all of its equipment to meet or exceed all of the required safety codes and regulations including CSA / UL / and CE.

We have also engineered other safety features into our equipment that we deem necessary for the operator's safety in this particular environment. Each piece of equipment is then inspected and certified by an independent third party before shipment.

Therefore any person or company who removes / disables or re-engineers any of the safety features on our equipment without prior written approval from Carney Battery Handling, will ultimately become responsible and liable for the safety of the operator and the modified equipment.

Please be advised:

Carney Battery Handling will not be held responsible for anyone who operates their equipment without the factory installed safety features and / or proper operator training.

Sincerely,

Wayne Carney

Position: CEO

Carney Battery Handling Ltd.

INDUSTRIAL BATTERY HANDLING SPECIALISTS

14 Regan Road, Unit 2A, Brampton, Ontario L7A 1B9 • Tel. (905) 564-0303 • Fax (905) 564-0313

PROSERIES[®]

BATTERY HANDLING SOLUTIONS

EnerSys EMEA Motive Power - Working in partnership with Carney Battery Handling Ltd.

STATEMENT OF WARRANTY

EnerSys Inc., warrants to the original purchaser of its equipment, that the equipment is free from defects in materials and workmanship under normal and proper use, operation and maintenance. This limited warranty shall remain in effect for a period of one (1) year or use of 2080 hours whichever expires first, from the delivery date of the equipment to the original purchaser.

The term "original purchaser", refers to the customer to whom the equipment was first delivered.

EnerSys Inc. will provide parts and labor to repair or replace (at EnerSys Inc.'s option) any part which is determined to be defective within the applicable warranty period.

All claims for defective products or parts under this warranty must be made in writing immediately upon discovery to EnerSys Inc. or an authorized EnerSys Inc. dealer by the original purchaser.

EnerSys Inc. will also cover normal ground freight charges such as couriers, common carriers, etc. Any special request such as same day or next day service will be the responsibility of the original purchaser.

This warranty does not cover damage or defects caused by overloading, abuse, misuse, accidents or failure to follow operation or maintenance instructions, or from other causes having an origin other than in the manufacture of the equipment. Fuses are not warranted unless found to be defective at commissioning.

EnerSys Inc. does not warrant and this warranty does not apply to accessories or attachments not manufactured by EnerSys Inc. which are incorporated in or delivered with the equipment and are warranted by their respective manufacturers.

At no time shall EnerSys Inc. assume liability in excess of the purchase price of said equipment for which a claim is made. The warranty set forth herein is the complete and entire warranty made by EnerSys Inc., and there are no other warranties, expressed or implied, whether of merchantability, fitness for particular purpose, or otherwise, made by EnerSys Inc. The right to repair or replace, as set forth herein is the sole and exclusive remedy for breach of the above warranty, and EnerSys Inc. shall not be liable for any damages, whether direct, incidental, consequential or otherwise, occasioned by any breach of this warranty, or for any charges or expenses of any nature incurred without EnerSys Inc.'s consent, even though EnerSys Inc. has been negligent.

PACEMAKER AND MAGNET INFORMATION



March 15, 2022

To whom it may concern:

Please accept this letter in response to your request regarding the impact of the electromagnet technology used on all Carney's battery equipment on the proper functioning of a pacemaker. Based on our research it is Carney's Battery Handling's contention that if the Battery Handling Equipment is used as intended and under normal operating conditions the risk of interference appears negligible, providing the device is using a bipolar sensing programming.

This takes into assumption that the medical device itself is operating as designed.

Based on these studies and the information as hand, we do not see any added risk created by the electromagnet technology used by Carney Battery Handling. However, it is the employee's responsibility to ensure that the pacemaker they have is a current model that is shielded and uses Bipolar leads.

Please contact you're a Carney Battery Handling representative should you have any further questions.

Sincerely,

Roland Mark, P.Eng.

Engineering Manager, Carney Battery Handling

HOW TO PLACE AN ORDER FOR PARTS

Please provide the following information:

1. Name, address and phone number of equipment owner:
2. Name of equipment including Model and Serial Numbers:
3. Part Number and Description:
4. Quantity:

It is imperative that Items 1 through 4 above be provided when ordering parts.

Failure to provide this information will only delay or prevent the processing of your order.

To order parts or for assistance in ordering parts, you may contact us by:



For Sales and Service: +41 (0)44 215 74 10



Fax: +41 (0)44 215 74 11

Notes:

PROSERIES[®]

BATTERY HANDLING SOLUTIONS

EnerSys EMEA Motive Power - Working in partnership with Carney Battery Handling Ltd.

ENERSYS EMEA

EH Europe GmbH
Baarerstrasse 18
6300 Zug
Switzerland

Phone: +41 (0)44 215 74 10 • Fax: +41 (0)44 215 74 11
Email: info@enersys-hawker.com
<http://www.enersys.com>

BATTERY HANDLING EXPERTISE

Whatever the size of your battery fleet, PRO Series® battery handling solutions can help you streamline your battery changing operation with a safe, productive and cost-efficient system. From initial design, drawings and engineering through to complete installation and project management, PRO Series® battery handling solutions can support your operation with everything you'll ever need for effective battery charging and changing. Let us plan your success.

PRO Series® battery handling solutions include a range of systems and equipment that comply with health and safety regulations. Using the latest CAD software, we will design a system that matches the needs of your business. With PROSeries® battery handling solutions, you'll enjoy the highest degree of safety and ease of operation of any equipment available today – all backed by our skilled design and installation capabilities.

OUR EXCLUSIVE PARTNERSHIP WITH CARNEY BATTERY HANDLING LTD

Since 1984, Carney Battery Handling Ltd has globally provided EnerSys® with turn-key battery room solutions, sharing our mission to innovate, design, and create quality critical battery room solutions as dedicated partners.

Our dependable alliance allows us to provide dedicated support, delivering tailored engineering and design individualized for every customer.

With an emphasis on quality and safety, all our equipment is rigorously tested for real-world environments ensuring its readiness to meet the demands of any application.

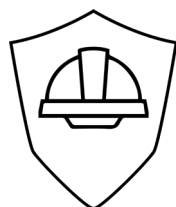

**COMMITTED TO QUALITY
EVERYWHERE FOR EVERYONE.**

www.enersys.com

PROSERIES®

WHEREVER YOU DO BUSINESS, ENERSYS® CAN SUPPORT YOU WITH MOTIVE POWER ENERGY.

ABOUT ENERSYS®

EnerSys, the global leader in stored energy solutions for industrial applications, manufactures and distributes energy systems solutions and motive power batteries, specialty batteries, battery chargers, power equipment, battery accessories and outdoor equipment enclosure solutions to customers worldwide.

Energy Systems, which combine enclosures, power conversion, power distribution and energy storage, are used in the telecommunication, broadband and utility industries, uninterruptible power supplies, and numerous applications.

Motive Power batteries and chargers are utilized in electric forklift trucks and other industrial electric powered vehicles requiring stored energy solutions. Specialty batteries are used in aerospace and defense applications, large over-the-road trucks, premium automotive, medical and security systems applications.

EnerSys also provides aftermarket and customer support services to its customers in over 100 countries through its sales and manufacturing locations around the world. With the recent NorthStar acquisition, EnerSys has solidified its position as the market leader for premium Thin Plate Pure Lead batteries which are sold across all three lines of business.

More information regarding EnerSys can be found at www.enersys.com.



EnerSys EMEA
EH Europe GmbH
Baarerstrasse 18
6300 Zug
Switzerland

EnerSys Ltd (UK)
Oak Court, M60 Office Park,
Wynne Avenue,
Swinton,
Manchester, M27 8FF

Please refer to the website address for details of your nearest EnerSys office: www.enersys.com

© 2022 EnerSys. All rights reserved. Trademarks and logos are the property of EnerSys and its affiliates unless otherwise noted. Subject to revisions without prior notice. E.&O.E.
EMEA-EN-OM-PRO-UNI-0722

EnerSys EMEA Motive Power - Working in partnership with Carney Battery Handling Ltd.

www.enersys.com

PROSERIES®

