



PowerNode System Enclosures

PN-3/PN-4



Technical Manual

PN-3 and PN-4 Models

Effective: April 2007

Alpha Technologies  [®]

Power

PowerNode System Enclosures PN-3 and PN-4 Models Technical Manual

031-103-B0-004, Rev. D

Effective Date: April, 2007

Copyright© 2007

Alpha Technologies, Inc.

member of The  Group™



NOTE:

Photographs contained in this manual are for illustrative purposes only. These photographs may not match your installation.



NOTE:

Operator is cautioned to review the drawings and illustrations contained in this manual before proceeding. If there are questions regarding the safe operation of this powering system, please contact Alpha Technologies or your nearest Alpha representative.



NOTE:

Alpha shall not be held liable for any damage or injury involving its enclosures, power supplies, generators, batteries, or other hardware if used or operated in any manner or subject to any condition not consistent with its intended purpose, or is installed or operated in an unapproved manner, or improperly maintained.

To contact Alpha Technologies:

Visit *www.alpha.com*

or

For general product information and customer service (7 AM to 5 PM, Pacific Time), call

1-800-863-3930,

For complete technical support, call

1-800-863-3364

7 AM to 5 PM, Pacific Time or 24/7 emergency support

To report errors in this document, send email to:

Techpubs@alpha.com

Table of Contents

Safety Notes	6
1.0 Introduction	8
2.0 Unpacking and Inspection	9
3.0 Site Preparation	10
3.1 Concrete Pad Preparation	11
3.2 Enclosure Grounding	12
3.3 Transportation and Lifting	14
3.4 Enclosure Mounting Procedure.....	14
4.0 Installation.....	15
4.1 Utility Powering	15
4.1.1 Connection Procedure for the BBX-100A-8POS Service Disconnect...	16
4.1.2 Connection Procedure for the BBX-70A Service Disconnect.....	17
4.1.3 Sample Input Power Panels.....	18
4.2 Coaxial Cable to Service Power Inserter (SPI) Installation.....	21
4.2.1 SPI to Ground Bar Connection Procedure	21
4.2.2 Conduit Placement.....	22
4.3 Battery Identification	23
4.4 Battery Terminal Connections	23
4.5 Battery Installation Procedure.....	26
4.5.1 Connecting the Battery Temperature Sensor	27
5.0 PN Series Options	28
5.1 Star Lock Security Bolt.....	28
5.2 Battery Interface Unit (BIU).....	29
5.3 Service Disconnects	29
5.4 Input Power Panel (IPP)	30
5.5 Lightning Arrester (LA-P+)	30
5.6 Cooling Fan Kit	31
6.0 Alpha Part Numbers	32
7.0 Pre-cast Pads	33

List of Figures

Fig. 1-1, PN-3 Specifications	8
Fig. 1-2, PN-4 Specifications	9
Fig. 2-1, Enclosure as it Arrives from Alpha	9
Fig. 2-2, Packing Label Location	9
Fig. 3-1, Suggested Site Selection for PN-3 and PN-4.....	10
Fig. 3-2, Single-Wide Concrete Pad for PN-3 and PN-4	11
Fig. 3-3, Suggested Grounding, PN-3 and PN-4.....	12
Fig. 3-4, Alternate Grounding, PN-3 and PN-4	13
Fig. 3-5, PN-3 Mounted to the Prepared Pad.....	14
Fig. 4-1, BBX-100A-8POS Service Disconnect.....	16
Fig. 4-2, BBX-70A Service Disconnect.....	17
Fig. 4-3, Schematic: Primary Service BBX-100A-8POS with IPP-240-3.....	18
Fig. 4-4, Schematic: Primary Service BBX-100A-8POS with IPP-120-3.....	18
Fig. 4-5, Schematic: Secondary Service BBX-100A-8POS with IPP-120-2	19
Fig. 4-6, Schematic: Secondary Service BBX-100A-8POS with IPP-240-2	19
Fig. 4-7, Schematic: Secondary Service BBX-70A with IPP-120-1	20
Fig. 4-8, Schematic: Primary Service BBX-70A with IPP-240-1	20
Fig. 4-9, Conduit Location	22
Fig. 4-10, Coaxial Connectors	22
Fig. 4-11, Alpha Cell Battery Date Code.....	23
Fig. 4-12, Terminal Connections.....	23
Fig. 4-13, Fuse Terminal Connection for Threaded Insert Batteries.....	24
Fig. 4-14, In-Line Fuse Link Mounting, Flag Terminal Batteries	24
Fig. 4-15, Hardware Installation for Fuse Terminal on Threaded Insert Battery	25
Fig. 4-16, Hardware Installation for Flag Terminal Connections.....	25
Fig. 4-17, PN-3/PN-4 Battery Installation	26
Fig. 4-18, Battery Temperature Sensor Mounting Location	27
Fig. 5-1, Battery Interface Unit Installed	29
Fig. 5-2, BBX 70A (BBX-FI2)	29
Fig. 5-3, BX 100A (BBX-FI8)	29
Fig. 5-4, MTS (Showing 100A and 60A boxes).....	29
Fig. 5-5, BBX 100A (BBX-FI8).....	29
Fig. 5-6, IPP for Three Power Supplies	30
Fig. 5-7, IPP for Two Power Supplies.....	30
Fig. 5-8, IPP for One Power Supply	30
Fig. 5-9, Breaker Duplex Option (BDO)	30
Fig. 5-10, LA-P+ Installed in BDO	30
Fig. 5-11, Location of LED on LA-P+	30
Fig. 5-12, Cooling Fan Panel	31
Fig. 5-13, Panel Installed in Top Rear of Enclosure	31
Fig. 5-14, Cooling Fan Plugged into Power Supply and SPI.....	31
Fig. 7-1, Single-wide Pad, for PN 3/4	33
Fig. 7-2, Double-wide Pad, for PN 3/4.....	34
Fig. 7-3, Double-wide Pad, for CE 3x2/9x2 and CE8/9 or PN 3/4.....	35

Safety Notes

Review the drawings and illustrations contained in this manual before proceeding. If there are any questions regarding the safe installation or operation of this product, contact Alpha Technologies or the nearest Alpha representative. Save this document for future reference.

To reduce the risk of injury or death, and to ensure the continued safe operation of this product, the following symbols have been placed throughout this manual. Where these symbols appear, use extra care and attention.

ATTENTION:

The use of ATTENTION indicates specific regulatory/code requirements that may affect the placement of equipment and /or installation procedures.



NOTE:

A NOTE provide additional information to help complete a specific task or procedure.



CAUTION!

The use of CAUTION indicates safety information intended to PREVENT DAMAGE to material or equipment.



WARNING!

WARNING presents safety information to PREVENT INJURY OR DEATH to the technician or user.

Installation Notes

- The system must be installed only by qualified service personnel.
- Always consult local codes for mounting pad requirements.
- Consult local utility codes for additional cabinet grounding and utility requirements.
- Consult the local gas company for correct meter type and riser location.
- Whenever possible, it is best that the enclosure be installed above flood zones.
- Precast Mounting Pads may either be purchased from Alpha or poured in place. The pad must be capable of holding 1,000 lbs. (minimum). Rebar may be placed in a crosshatch pattern for pad reinforcement, as needed.
- If the pad is to be located in an area with a deep frost line or unstable soil, concrete pylon footings (4" diameter X 4' deep, or 1' deeper than the regional frost line) can be placed below the concrete pad, in front of and below the (4) mounting features.
- The top of the pad must be above grade to reduce the buildup of debris around the base of the cabinet.
- Adequate space must be allowed for Cable TV input/output conduit; plant grounding electrode conductor(s); RF cable entrance via (1) 4", (2) 3" or (3) 2 1/2" rigid conduit sweep(s) with 2' bend radius (minimum); and fiber optic cable entrance (refer to fiber manufacturer's specification for minimum bend radius requirements).
- Prior to pouring concrete, any wire running through the pad must have a thermal expansion jacket (i.e., PVC) to prevent cracking of the concrete during lightning strikes.
- Alpha Technologies is not responsible for broken welds or other damage to the cabinet caused by improper installation.
- A 25+ year vapor barrier must be used between the concrete pad and the base of the enclosure to further inhibit the ingress of moisture. Alpha Technologies is not responsible for water damage or moisture damage resulting from improper installation.
- Concrete filled, 6" diameter steel posts (or equivalent) can be placed at the corners of the pad to reduce exposure to accidental traffic damage.
- All dimensions are given in inches.
- For further information regarding this installation, contact Alpha Technologies or your nearest Alpha representative.

Battery Safety Notes



Lead-acid batteries contain dangerous voltages, currents and corrosive material. Battery installation, maintenance, service and replacement must be performed only by authorized personnel.

Chemical Hazards

Any gelled or liquid emissions from a valve-regulated lead-acid (VRLA) battery contain dilute sulfuric acid, which is harmful to the skin and eyes. Emissions are electrolytic, and are electrically conductive and corrosive.

To avoid injury:

- Servicing and connection of batteries shall be performed by, or under the direct supervision of, personnel knowledgeable of batteries and the required safety precautions.
- Always wear eye protection, rubber gloves, and a protective vest when working near batteries. Remove all metallic objects from hands and neck.
- Batteries produce explosive gases. Keep all open flames and sparks away from batteries.
- Use tools with insulated handles, do not rest any tools on top of batteries.
- Batteries contain or emit chemicals known to the State of California to cause cancer and birth defects or other reproductive harm. Battery post terminals and related accessories contain lead and lead compounds. Wash hands after handling (California Proposition 65).
- Wear protective clothing (insulated gloves, eye protection, etc.) whenever installing, maintaining, servicing, or replacing batteries.
- If any battery emission contacts the skin, wash immediately and thoroughly with water. Follow your company's approved chemical exposure procedures.
- Neutralize any spilled battery emission with the special solution contained in an approved spill kit or with a solution of one pound Bicarbonate of soda to one gallon of water. Report chemical spill using your company's spill reporting structure and seek medical attention if necessary.
- Always replace batteries with those of an identical type and rating. Never install old or untested batteries.
- Do not charge batteries in a sealed container. Each individual battery should have at least 0.5 inches of space between it and all surrounding surfaces to allow for convection cooling.
- All battery compartments must have adequate ventilation to prevent an accumulation of potentially dangerous gas.
- Prior to handling the batteries, touch a grounded metal object to dissipate any static charge that may have developed on your body.
- Never use uninsulated tools or other conductive materials when installing, maintaining, servicing or replacing batteries.
- Use special caution when connecting or adjusting battery cabling. An improperly connected battery cable or an unconnected battery cable can make contact with an unintended surface that can result in arcing, fire, or possible explosion.
- A battery showing signs of cracking, leaking, or swelling should be replaced immediately by Authorized Personnel using a battery of identical type and rating.

1.0 Introduction

Alpha's PN Series Power Node enclosures offer complete flexibility and modular expandability for Cable TV powering applications. The Modular Tray system simplifies installation while allowing for future expansion or reconfiguration. The PN Series is designed to accommodate current system power requirements while allowing the cost-effective addition of power capacity, as well as enhanced reliability options, when new services are integrated. Excellent for either distributed or centralized powering architectures, PN Series enclosures are available to accommodate multiple power supplies, battery strings and/or natural gas or propane generators.

Fig. 1-1, PN-3 Specifications
Dimensions: 26" W x 44" H x 24" D
Power Supply Capacity: Up to two power supplies (4kW)
Weight: 100-170 lbs. (depending on options)
Material: Aluminum

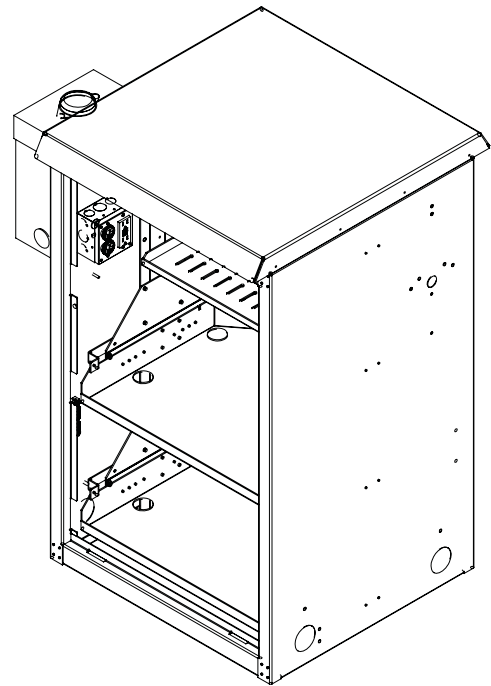
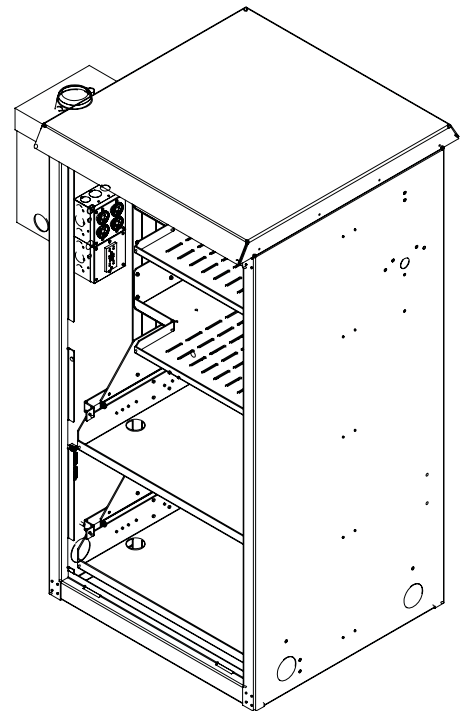

Fig. 1-2, PN-4 Specifications
Dimensions: 26" W x 52" H x 24" D
Power Supply Capacity: Up to three power supplies (6kW)
Weight: 110-180 lbs. (depending on options)
Material: Aluminum



2.0 Unpacking and Inspection

To ensure operator safety:

- Enclosures must be installed only by qualified personnel and in accordance with all applicable electrical codes.
- Use eye protection whenever working with batteries.
- Use only sealed, lead-acid type batteries (gelled-electrolyte or equivalent, 65Ah min).

Unpacking and Inspection:

Carefully remove the enclosure from the shipping container. Inspect the contents. If there are damaged or missing items, contact Alpha Technologies and the shipping company immediately. Most shipping companies have only a short claim period.

Verify the order contents (refer to packing label details located on wooden pallet, see Fig. 2-2).



NOTE:

Batteries are shipped separately.



Fig. 2-1, Enclosure as Shipped



Fig. 2-2, Packing Label Location

3.0 Site Preparation

The site must be planned so that the enclosure will receive good air flow. In areas of extreme heat, position the enclosure so that it will be shaded from the afternoon sun. In areas of prevailing winds, it is best that the enclosure be located so that the sides of the cabinet face the winds instead of the doors. This will greatly reduce the buildup of sand or snow against the enclosure's air vents.

In areas of potential flooding, the geographical site and concrete pad must be located above the flood plain. Pedestals are available to raise the Power Node enclosures above expected snow and water levels.

The enclosure must be placed where it will be free of obstructions, allowing easy access to the doors for service or equipment access. For ventilation and maintenance, allow a minimum space of 36 inches in the front and 36 inches in the rear, between the enclosure and other solid structures.

Place the enclosure well away from ground level sources of forced water, such as underground sprinkler systems and direct roadway splash.

The concrete pad drawing (Section 3.1) contains all of the required mounting details, including electrical service and cable plant entrances.

The vapor barrier material (such as 30 lb. felt, neoprene pond liner, or heavy grade tar paper) must initially extend at least 6" in all directions around the perimeter of the enclosure and be trimmed closer to the enclosure, using the appropriate utility knife or cutting tool.



WARNING!

Never transport the unit with batteries installed. Batteries must ONLY be installed after the unit is transported to the site and secured to the pad. Transporting the unit with batteries installed may cause a short circuit, fire, explosion, and/or damage to the battery pack, enclosure and installed equipment. Damage caused by improper shipping or transporting a unit with batteries installed is not covered under warranty.

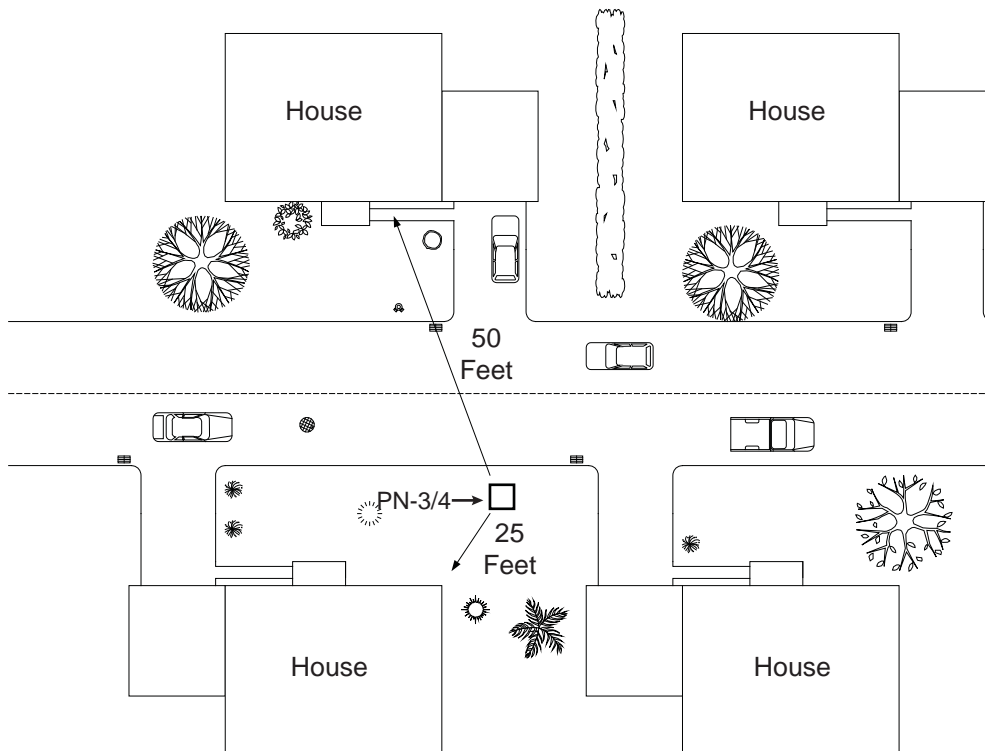

Fig. 3-1, Suggested Site Selection for PN-3 and PN-4

3.0 Site Preparation, continued

3.1 Concrete Pad Preparation

Pads can either be poured on site, or precast by Alpha Technologies. Available concrete pad configurations and part numbers can be found in Section 6.

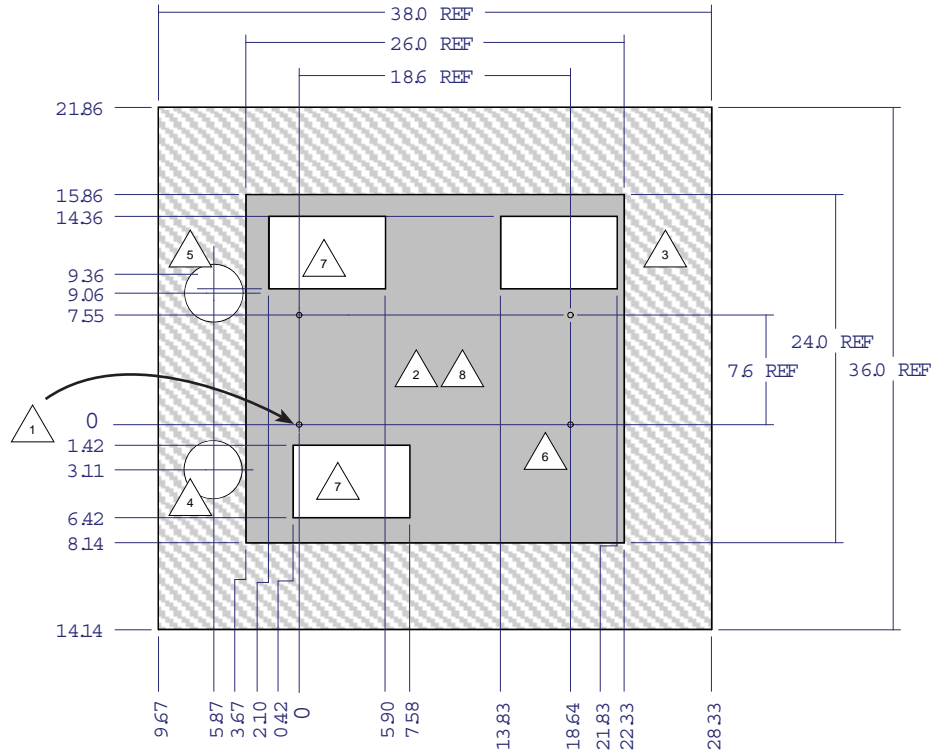

Fig. 3-2, Single-wide Concrete Pad for PN-3 and PN-4
All dimensions shown in inches

- 1 Mounting holes and sweeps indexed from this position.
- 2 Indicates PN-3 and PN-4 pedestal enclosure mating surface.
- 3 Alpha recommended distance (6" minimum) between edge of pad and cabinet.
- 4 Four-inch diameter hole for AC power IN (non-metered installation).
- 5 Four-inch diameter opening for DC Output cable and Status Monitoring harness.
- 6 All mounting hardware must be stainless, galvanized, or better to prevent corrosion.
- 7 5" x 8" rectangular cutout (2 places), open area for all internal connections including: generator power and/or coax cable conduit sweeps.
- 8 A 25+ year continuous vapor barrier must be used between the enclosure and the pad to prevent moisture ingress and possible corrosion caused by metal to concrete contact. The vapor barrier material (such as 30 lb. felt, neoprene pond liner, or heavy grade tar paper) must be initially extended at least 6" in all directions around the perimeter of the enclosure. After the enclosure is secured to the pad, the material can be cut closer to the enclosure, using the appropriate knife or cutting tool.

3.0 Site Preparation, continued

3.2 Enclosure Grounding

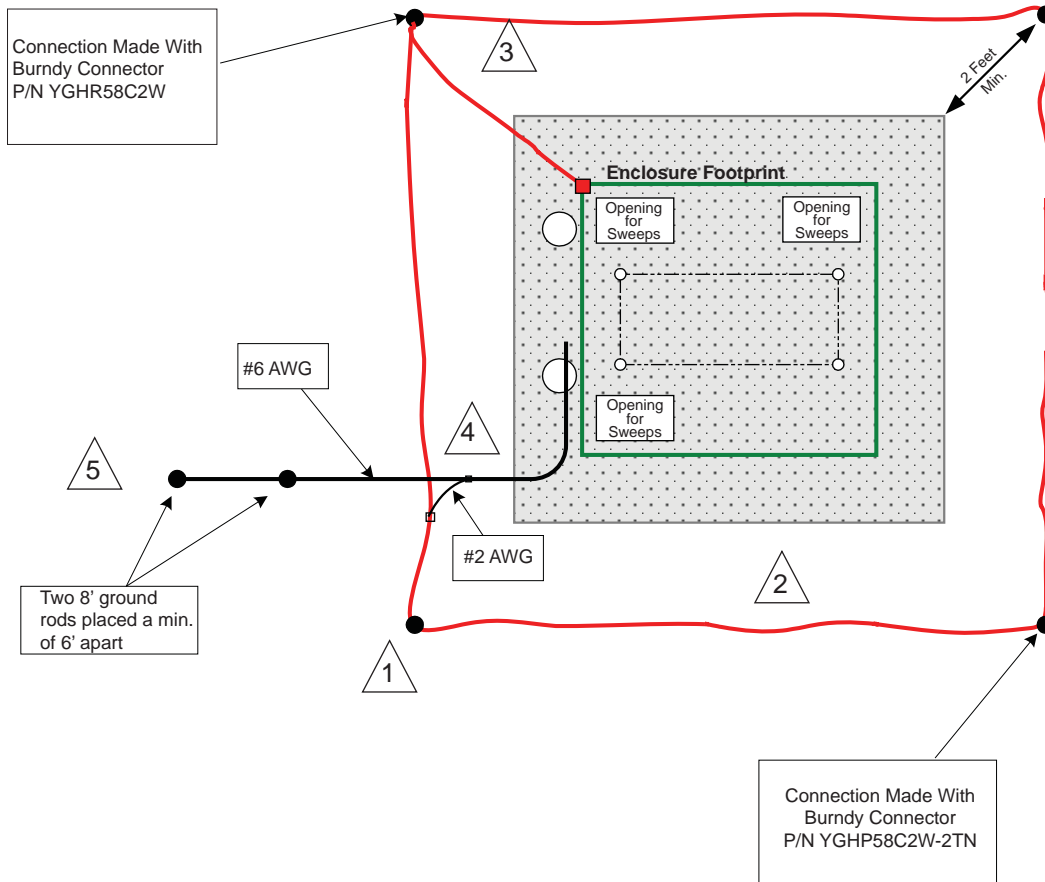

Fig. 3-3, Suggested Grounding, PN-3 and PN-4

Lightning Protection (Optional)

- 1 1/2" x 8' copper ground rod, four places, driven about 2 feet (typical) from the corners of the pad.
- 2 #2 bare copper wire loop terminated to each ground rod and buried below grade 2 to 12 inches. Corrosion-proof connections (25+ year life-span) and hardware suitable for direct burial MUST be used.
- 3 #2 bare copper wire from loop to the enclosure.
- 4 When the electrical supply is a primary service (not a secondary or feeder service) a #2 bare copper wire must be bond the lightning protection loop to the Grounding Electrode Conductor where they are closest.

Service Grounding (required)

- 5 #6 bare copper wire from Service Neutral/Ground Bar with 2 ground rods located 6' apart.

3.0 Site Preparation, continued

3.2 Enclosure Grounding, continued

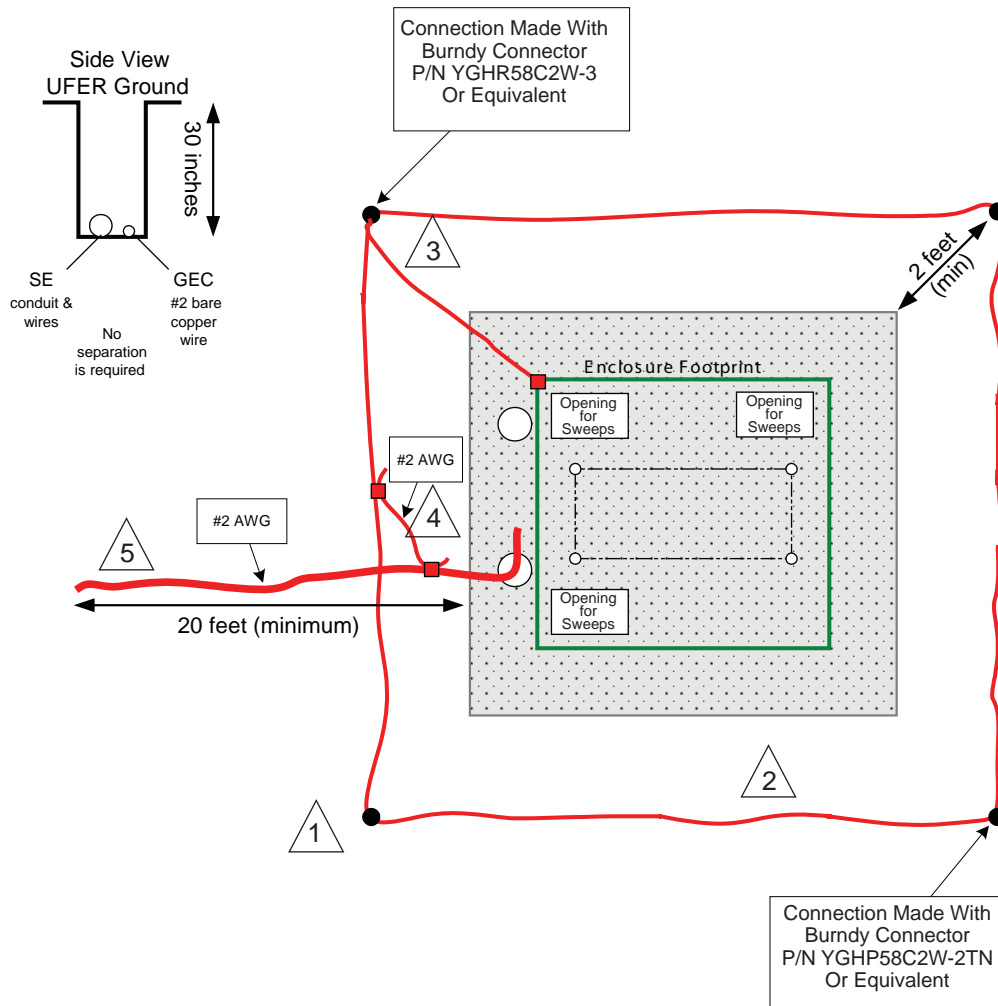

Fig. 3-4, Alternate Grounding, PN-3 and PN-4

Lightning Protection (Optional)

- 1 1/2" x 8' copper ground rod, four places, driven about 2 feet (typical) from the corners of the pad.
- 2 #2 bare copper wire loop terminated to each ground rod and buried below grade 2 to 12 inches. Corrosion-proof connections (25+ year life-span) and hardware suitable for direct burial MUST be used.
- 3 #2 bare copper wire from loop to the enclosure.
- 4 When the electrical supply is a primary service (not a secondary or feeder service) a #2 bare copper wire must be bonded to the lightning protection loop to the Grounding Electrode Conductor where they are closest.

Service Grounding (required)

- 5 #2 bare copper wire from Service Neutral/Ground Bar down 30" and out 20' beyond the pad edge. This is often called a UFER ground (Ground Ring in the NEC).

3.0 Site Preparation, continued

3.3 Transportation and Lifting

The PN-3 or PN-4 cabinet as shipped weighs approximately 100-150 lbs. A safe means of transportation to the site and a safe procedure for unloading the enclosure is necessary. Do not transport or lift with a device that may not be able to bear the unit's weight, and do not place the unit upon a surface that will not be able to fully support it.

 CAUTION!

- Enclosure must always remain in the upright position during shipping, storage, and installation. Damage may result from enclosure being shipped or stored on its side.
- Electronic modules, batteries or other components must not be installed until the enclosure is securely set in place at its permanent location.

3.4 Enclosure Mounting Procedure

The enclosure bolts directly to the concrete pad. Mounting holes are provided in the base of the internal enclosure rack to accommodate the pad's 3/8" stainless or galvanized anchor bolts.

1. Place vapor barrier material on pad and make cutouts for anchoring hardware and other openings as necessary. A 25+ year vapor barrier MUST be used between the concrete and enclosure base to inhibit moisture ingress and to prevent corrosion caused by concrete-to-metal contact.
2. With no less than two field personnel lifting the enclosure, position it above the concrete pad and slowly lower it into position over the pad's 3/8" anchor bolts.
3. Secure the enclosure using stainless, galvanized (or better) flat washers, lock washers and 3/8" nuts at each mounting bolt.
4. Install electronic modules and batteries at this time.

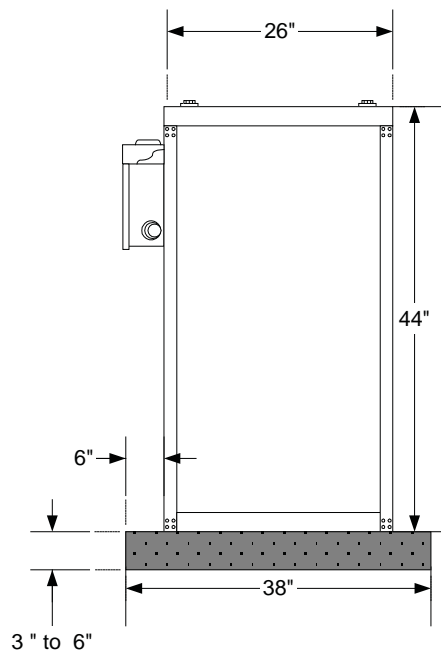

Fig. 3-5, PN-3 Mounted to the Prepared Pad

4.0 Installation

4.1 Utility Powering

XM2 Power Supplies are powered by either 120Vac or 240Vac (depending on the model), attached to an external service entrance. The size of the service conductors must be based on the actual size of the utility service and be in accordance with applicable electrical code requirements.

The utility conduit may be placed in one of two locations, depending upon the utility service entrance requirements. Note the optional conduit location for use with meter base and the standard location for entry directly to the load center.

Proper grounding is critical. The enclosure **MUST** have a hard-wired ground to the service entrance. A qualified electrician will need to verify that grounding is in compliance with applicable electrical codes (refer to Section 3.2, Enclosure Grounding).

Both standard and EUSERC style meter bases are available for some configurations as illustrated in the following figures. Consult Alpha Technologies or your local representative regarding compatibility with your specific application. Verify electrical codes prior to installation. Codes may vary and contain specific conduit and wire sizes for connection to the service entrance.

The enclosure is equipped with a Square D, rainproof service entrance (SUSE rated). The service entrance is equipped with a circuit breaker for a 120/240Vac, split phase, 3-wire w/GND source.

Materials Required:

- 1" diameter conduit (or larger)- PVC or Galvanized Steel (threaded)
- #6 AWG - Red insulated wire (stranded)
- #6 AWG - Black insulated wire (stranded)
- #6 AWG - White insulated wire (stranded)
- #2 AWG or larger - copper ground wire (stranded)

ATTENTION:

The following utility powering procedures must be performed only by qualified service personnel and in compliance with local electrical codes. All applicable codes must be adhered to when installing a system, pouring concrete, or placing a preformed pad. These codes supersede any procedures outlined in this document.



CAUTION!

- All mounting hardware must be stainless or galvanized, depending on local environmental conditions. Use of improper hardware may cause corrosion, which is not covered under warranty.
- Soil conditions vary and may affect the integrity of the pad. Alpha Technologies recommends that proper steps be taken to ensure that the soil supporting the pad is stable. Improper installation of the pad may cause uneven settling or cracking, which is not covered under warranty.

4.0 Installation, continued

4.1 Utility Powering, continued

4.1.1 Connection Procedure for the BBX-100A-8POS Service Disconnect:

1. Locate the service entrance panel on the enclosure (exterior). Remove the cover to access the circuit breaker assembly. If this service panel is to be used as the primary service entrance, neutral must be bonded to ground by installing the green bonding screw (provided) in the hole in the neutral bus.
2. Remove the knockout located at the base of the service entrance to accept the conduit.
3. Install the conduit nipple into the service entrance via the knockout and secure with the appropriate threaded conduit locknut.
4. Locate the two screw terminals (L1 and L2) on the bottom of the input circuit breaker.
5. Connect one of the incoming black #6 AWG wires to L1 (left terminal). Connect the remaining black (or red) #6 AWG wire to L2 (right terminal). Note: if the wire at L2 is black, mark it with red tape (or label).
6. Connect the white #6AWG wire to the neutral (N) bus lug, located to the top right of the circuit breaker assembly.
7. Connect the #6AWG bare solid or stranded wire for the Grounding Electrode Conductor (earth ground) to the ground and neutral bus located to the right side of the circuit breaker assembly.
8. Notify the electrical inspector to approve the service entrance wiring. Once approved, contact the local power utility for electrical service.

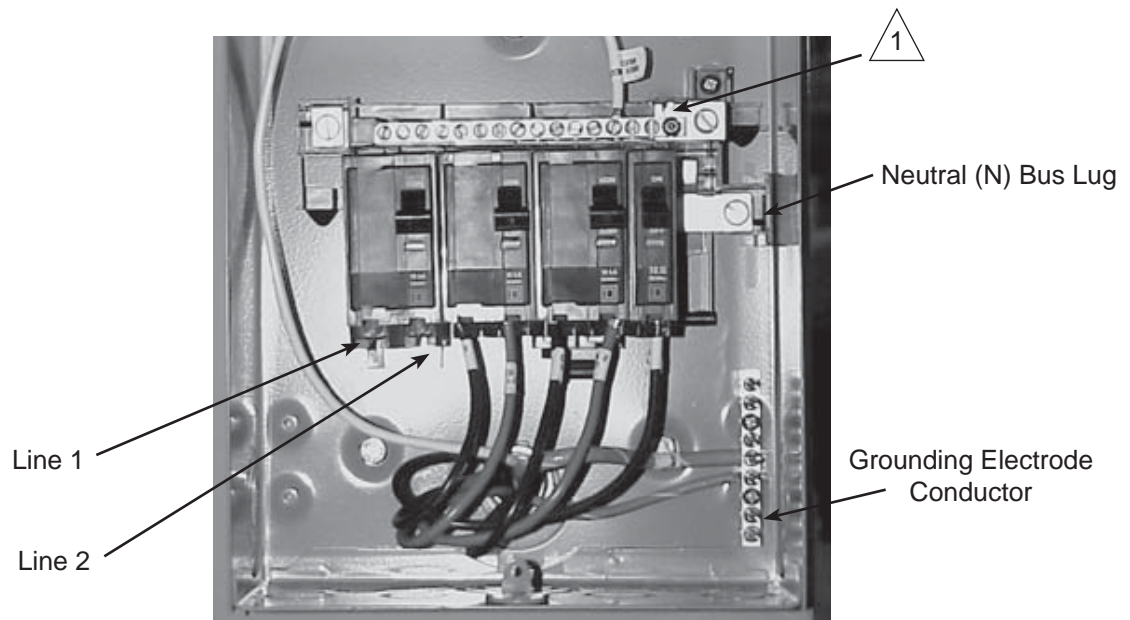

Fig. 4-1, BBX-100A-8POS Service Disconnect



Bond made by bonding screw only if no other service panel is used (must be installed on site only if primary service entrance).

4.0 Installation, continued

4.1 Utility Powering, continued

4.1.2 Connection Procedure for the BBX-70A Service Disconnect:

1. Locate the service entrance panel on the enclosure (exterior). Remove the cover to access the circuit breaker assembly. If this service panel is to be used as the primary service entrance, neutral must be bonded to ground by installing the green bonding screw (provided) in the hole in the neutral bus.
2. Remove the knockout located at the base of the service entrance to accept the conduit.
3. Install the conduit nipple into the service entrance via the knockout and secure with the appropriate threaded conduit locknut.
4. Locate the Line screw terminal on the top of the input circuit breaker.
5. Connect the incoming black #6AWG wire to Line.
6. Connect the white #6AWG wire to the neutral (N) bus lug located to the top right of the circuit breaker assembly.
7. Connect the #6 bare solid or stranded for Grounding Electrode Conductor (earth ground) to the ground and neutral bus located to the right side of the circuit breaker assembly.
8. Notify the electrical inspector to approve the service entrance wiring. Once approved, contact the local power utility for electrical service.

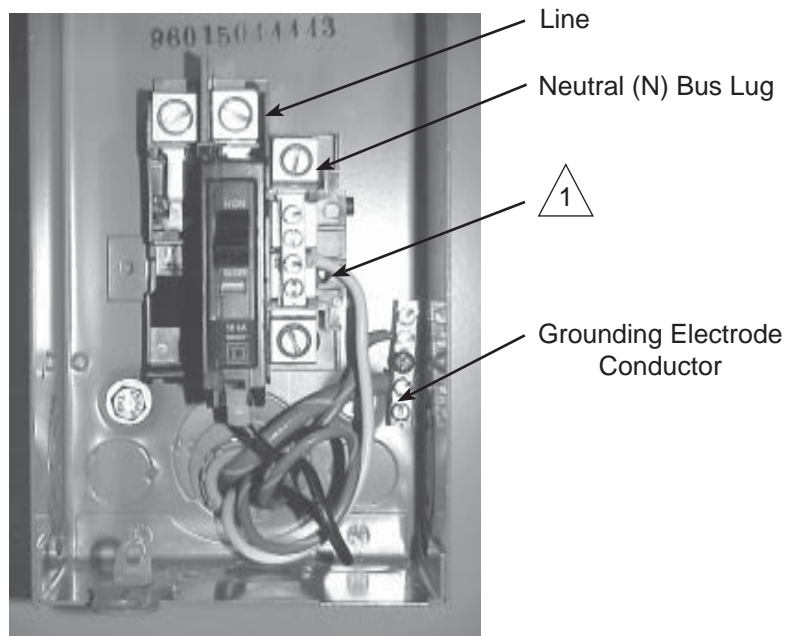

Fig. 4-2, BBX-70A Service Disconnect



Bond made by bonding screw only if no other service panel is used (must be installed on site only if primary service entrance).

4.0 Installation, continued

4.1 Utility Powering, continued

4.1.3 Sample Input Power Panels

For more information on available models of the Input Power Panel, refer to Section 5.0, PN Series Options.

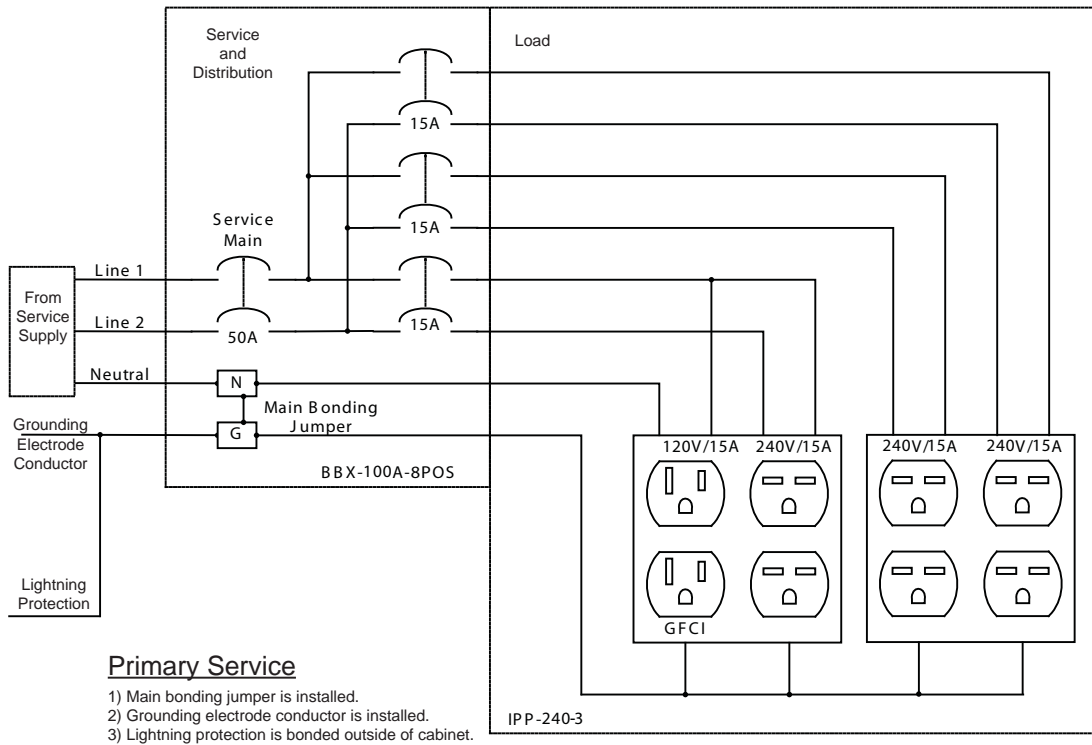

Fig. 4-3, Schematic: Primary Service BBX-100A-8POS with IPP-240-3

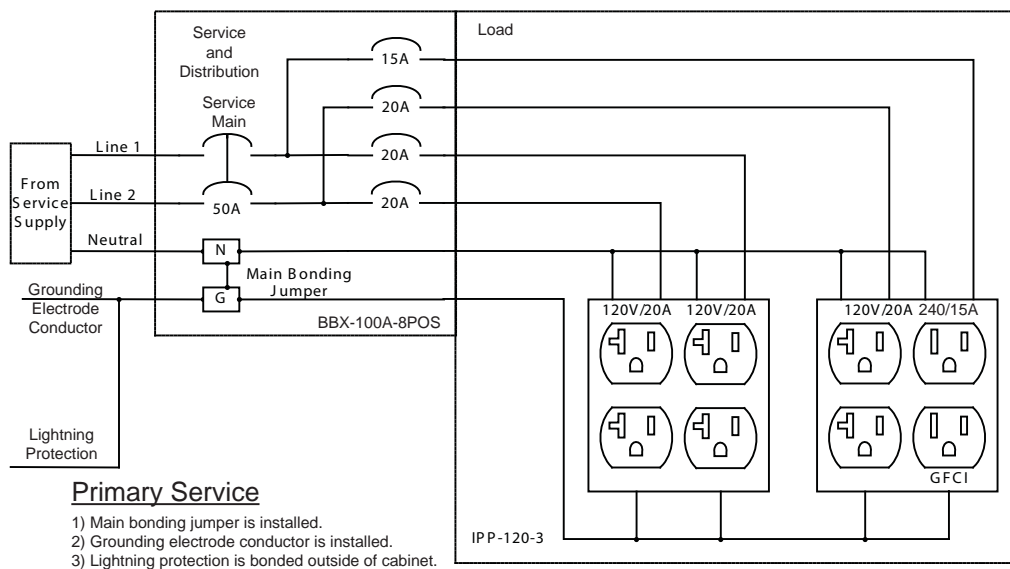

Fig. 4-4, Schematic: Primary Service BBX-100A-8POS with IPP-120-3

4.0 Installation, continued

4.1 Utility Powering, continued

4.1.3 Sample Input Power Panels, continued

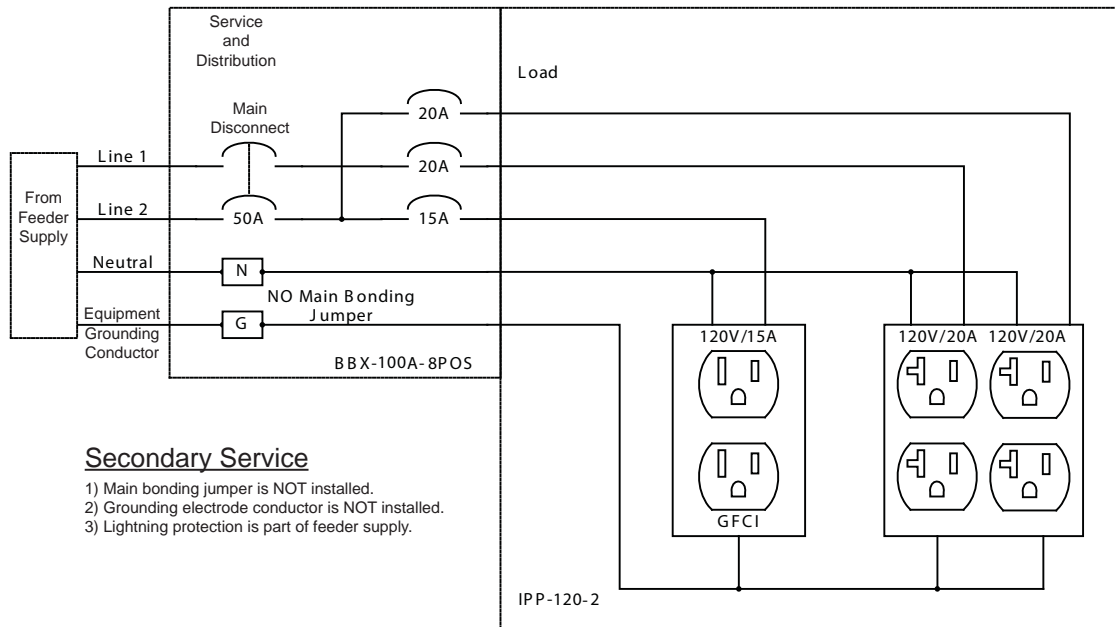

Fig. 4-5, Schematic: Secondary Service BBX-100A-8POS with IPP-120-2

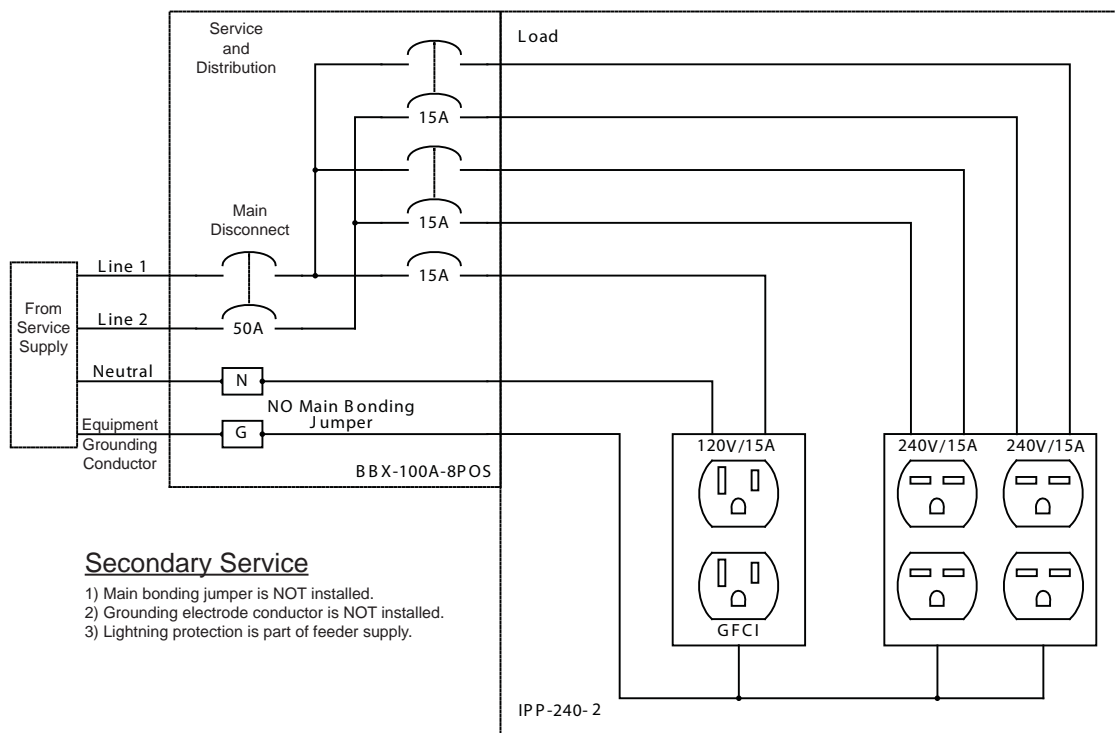

Fig. 4-6, Schematic: Secondary Service BBX-100A-8POS with IPP-240-2

4.0 Installation, continued

4.1 Utility Powering, continued

4.1.3 Sample Input Power Panels, continued

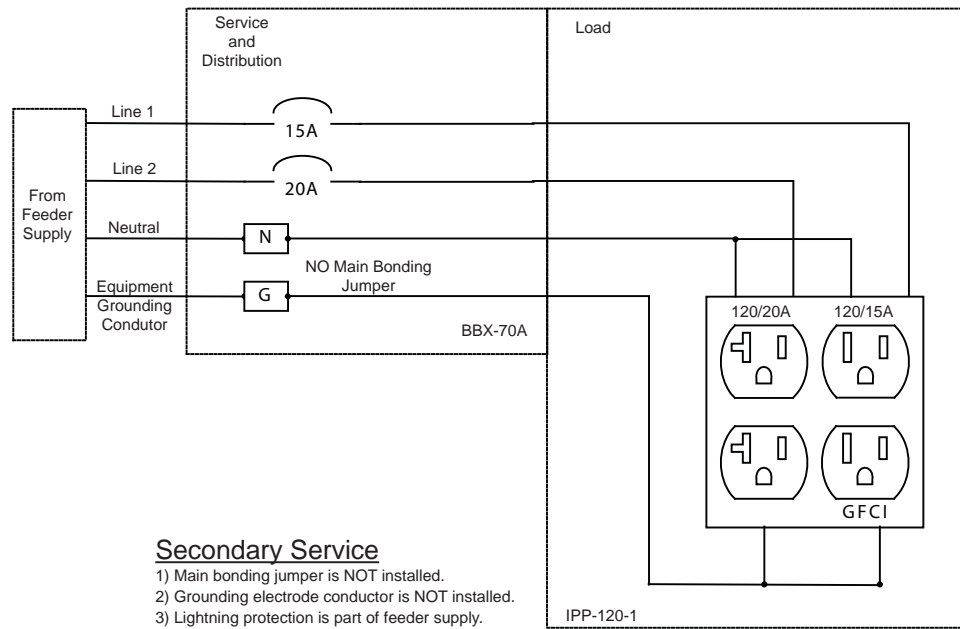

Fig. 4-7, Schematic: Secondary Service BBX-70A with IPP-120-1

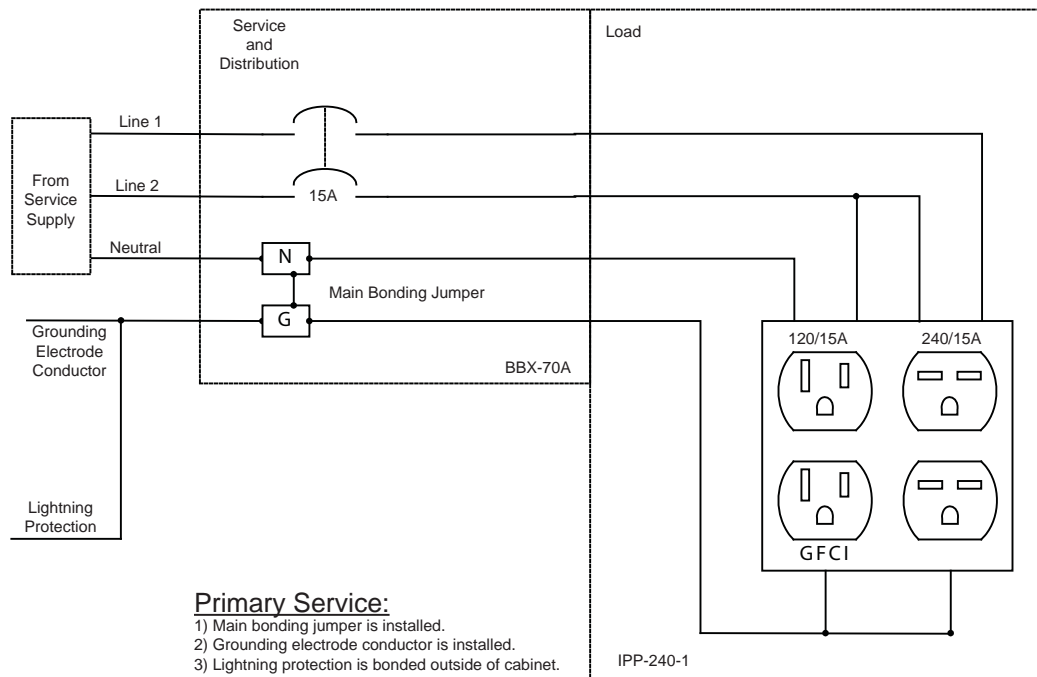

Fig. 4-8, Schematic: Primary Service BBX-70A with IPP-240-1

4.0 Installation, continued

4.2 Coaxial Cable to Service Power Inserter (SPI) Installation

4.2.1 SPI to Ground Bar Connection Procedure

Tools List:

- 1" Socket (3/8" drive)
- 3/8" Ratchet
- #2 Phillips Screwdriver
- Zip Tie Gun

1. Install SPI by tightening the attached coaxial connector to the equipment tray.

Connector Fitting →

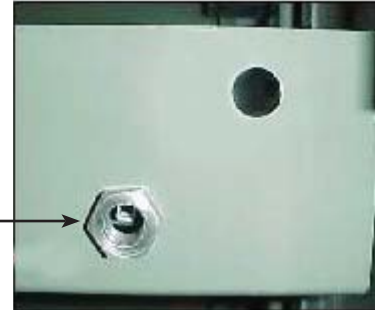

2. Secure SPI ground wire to the SPI with attached screw.



3. Terminate stripped end of wire at enclosure ground bar.



4.0 Installation, continued

4.2 Coaxial Cable to Service Power Inserter (SPI) Installation, continued

4.2.2 Conduit Placement

Conduit location is in the back of the enclosure, on the right side. The location is specified on concrete pad.



Fig. 4-9, Conduit Location



Fig. 4-10, Coaxial Connectors

4.0 Installation, continued

4.3 Battery Identification

Each battery contains a DATE CODE. This date code must be recorded in the maintenance log. If batteries other than those sold by Alpha are used, consult the battery manufacturers' documentation for date code type and placement.

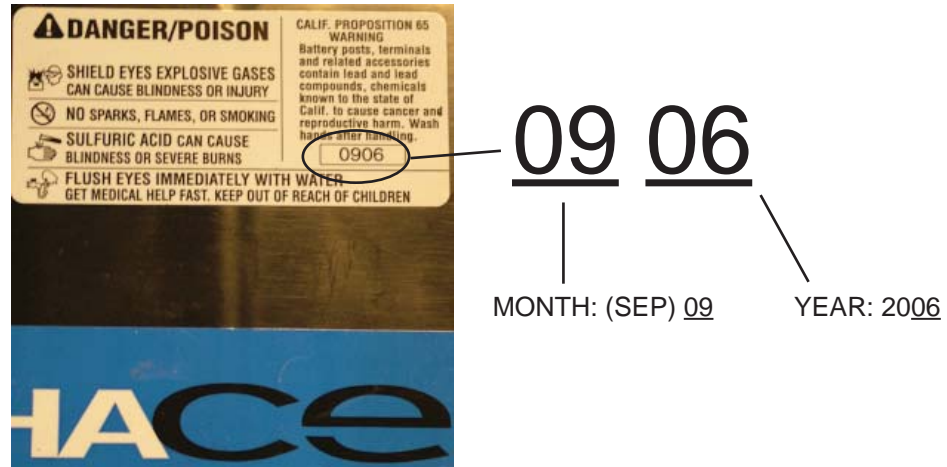

Fig. 4-11, Alpha Cell Battery Date Code

4.4 Battery Terminal Connections

The accompanying drawings are for illustrative purposes only. Various types of batteries with different mounting styles and hardware may be installed with the system. ALWAYS refer to the battery manufacturer's specifications for correct mounting hardware and torque requirements. During maintenance procedures, refer to the manufacturer's specifications for the maintenance torque requirements.

Mounting hardware requirements may vary with battery manufacturers. Use only the hardware recommended by your particular battery manufacturer.

As of January 1, 2007, AlphaCell batteries will be manufactured with threaded insert terminals. Previous AlphaCell models with flag terminals will no longer be available. To facilitate this change, each AlphaCell battery is shipped with two 3/4", 1/4-20 bolts, washers, and lock washers for terminal connections.



CAUTION!

Do not use the 1" hardware included with the Battery Cable Kit for connecting directly to the threaded insert terminals. The threaded inserts are only 3/4" deep. Using 1" hardware will damage the battery and void the warranty.

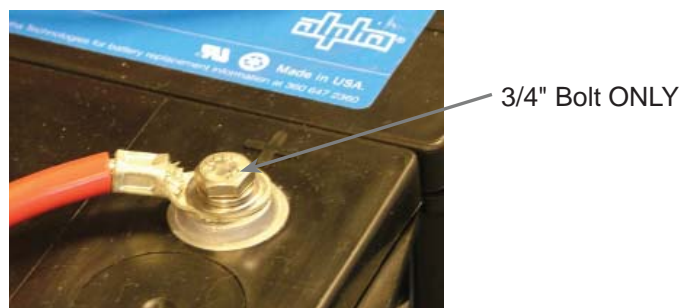

Fig. 4-12, Terminal Connections

4.0 Installation, continued

4.4 Battery Terminal Connections, continued

Remove one 1" bolt from the Battery Cable Kit (BCK) hardware for making the fuse terminal connection. For all other terminals, use the 3/4" hardware included with the batteries.

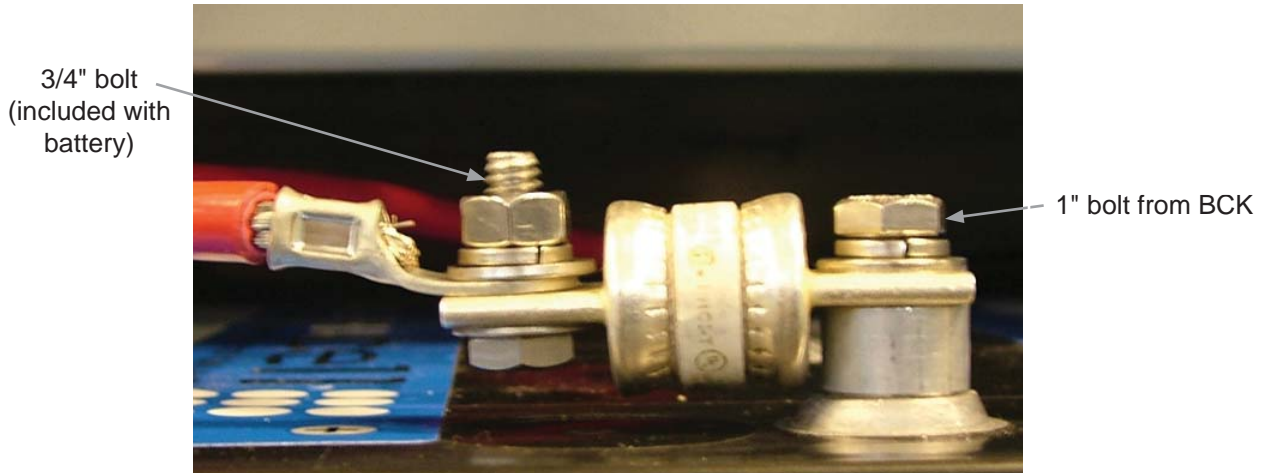

Fig. 4-13, Fuse Terminal Connection for Threaded Insert Batteries



NOTE:

Use a corrosion inhibitor (such as NCP-2) on battery terminals.

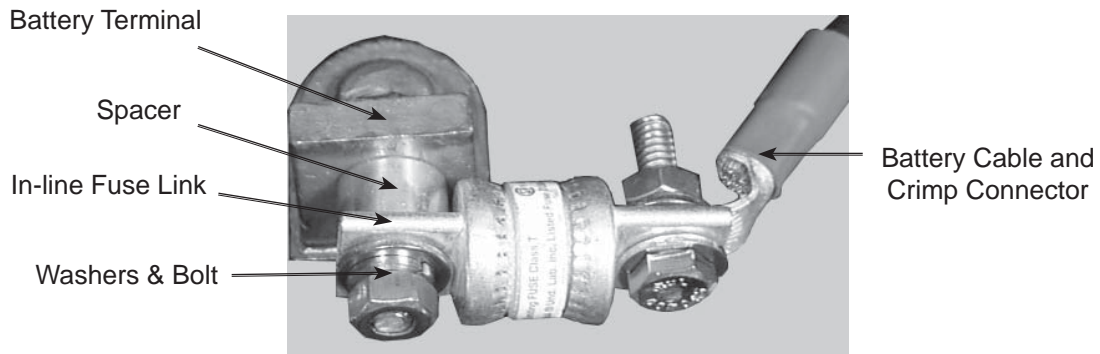

Fig. 4-14, In-Line Fuse Link Mounting, Flag Terminal Batteries

4.0 Installation, continued

4.4 Battery Terminal Connections, continued

Refer to the battery manufacturers' specifications for tightening torque.

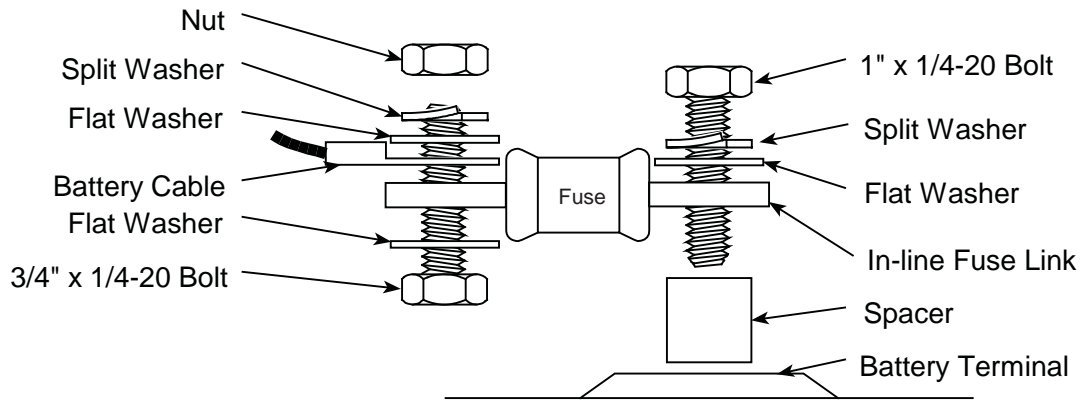

Fig. 4-15, Hardware Installation for Fuse Terminal on Threaded Insert Battery

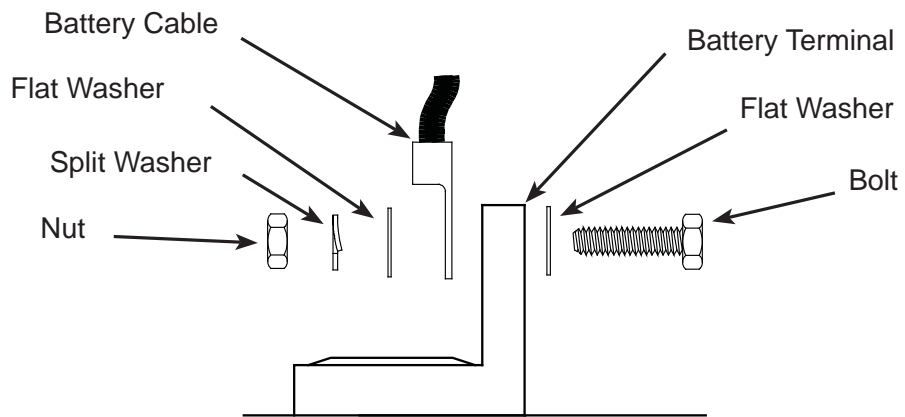

Fig. 4-16, Hardware Installation for Flag Terminal Connections

4.0 Installation, continued

4.5 Battery Installation Procedure

1. Place the batteries on their respective shelves as shown in the figures below.
2. Connect the three (or four) batteries in series (negative to positive) to achieve 36Vdc (or 48Vdc). Route the battery cables inside the vertical rail for connection to the power supply. Torque terminal connector according to battery manufacturer recommendations (see battery label for torque specifications). Typical torque specification for AlphaCell brand batteries is 65 in-lbs for initial installation, and retorquing @ 50 in-lbs during maintenance.
3. Use a voltmeter to verify polarity and DC voltage at the module's battery connector.

CAUTION!

- Whenever making or breaking battery connections, never allow live battery cables to contact the chassis. If necessary, wrap the lugs with electrical tape to prevent arcing and temporarily disconnect one of the leads from the center battery. Check the battery voltages at the connectors leading into the power supply.
 - Ensure that voltage and polarity are correct before proceeding.
4. Mate the battery connectors to their respective sockets on the power supply module.
 5. Number the batteries 1, 2, 3, (4) using labels, masking tape, or china marker. Record each battery's number and date code in the power supply's maintenance log. Battery Number 1 is connected to the negative lead from the power supply.
 6. For installations with multiple battery strings in parallel, each string must be fused. Verify that the enclosure was ordered with a fused Battery Cable Kit (BCK). For replacement fuses, or to add fuses to a BCK without fuses, order the Battery Terminal Fuse Kit, Alpha P/N 744-863-20.

Red (+) Black (-)

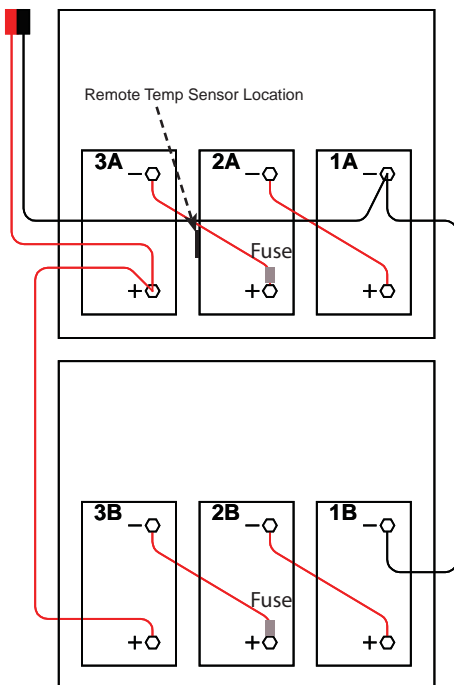

PN-3

Red (+) Black (-)

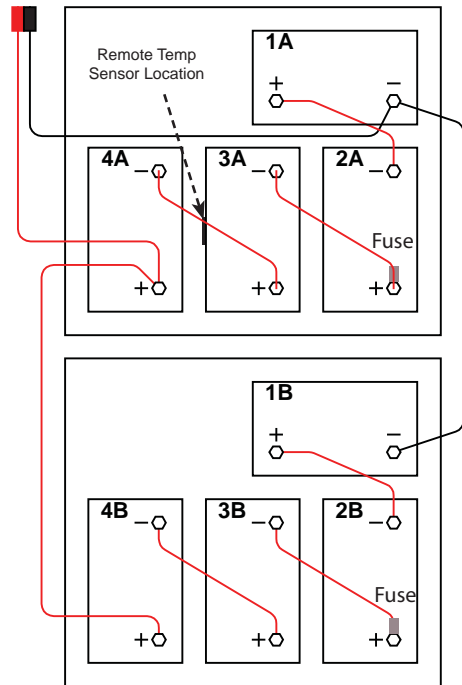

PN-4

Fig. 4-17, PN-3/PN-4 Battery Installation

4.0 Installation, continued

4.5 Battery Installation Procedure, continued

4.5.1 Connecting the Battery Remote Temperature Sensor (RTS)

The Remote Temperature Sensor (RTS) wiring connects to Temperature Sensor Input connector of XM2 Power Supply. Tape the sensor to the side of the middle battery in the string, so that the flat side of the sensor is flush to the side of the battery.

To prevent incorrect temperature readings, attach the Battery Temperature Sensor associated with each XM2 Power Supply on different batteries.

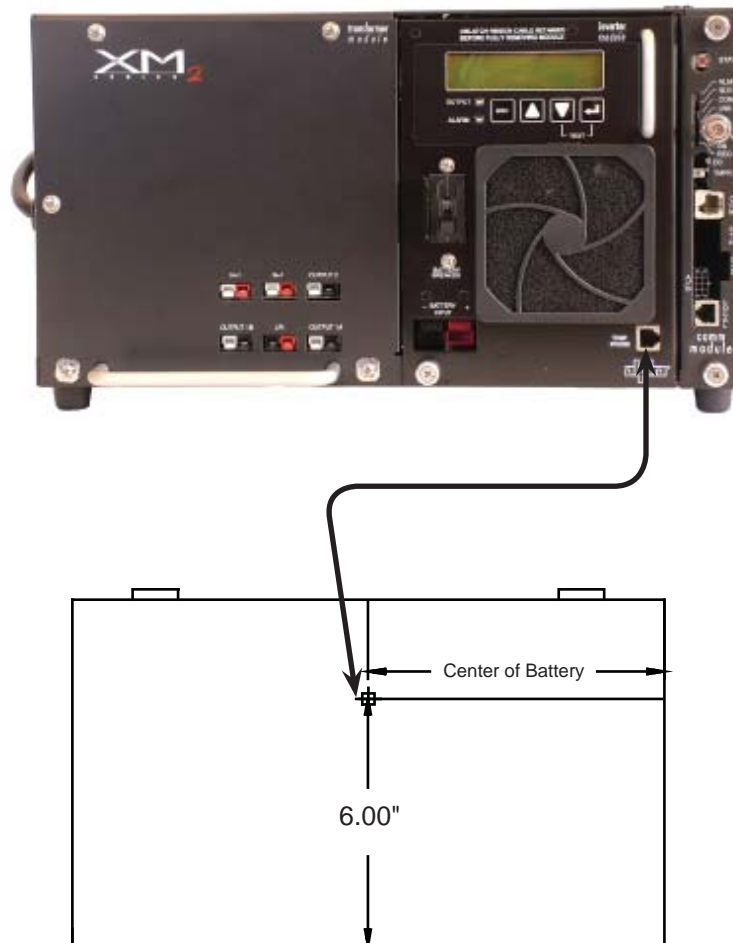

Fig. 4-18, Battery Temperature Sensor Mounting Location

5.0 PN Series Options

5.1 Star Lock Security Bolt

The Star Lock Security Bolt kit comes factory installed when ordered with a new enclosure. The kit can also be added to existing enclosures using the procedure below. See Section 6.0, Alpha Part Numbers, for PN Series options shown in this section.



NOTE:

The Security Key is a special tool that must be ordered separately. Alpha recommends ordering security keys for each maintenance crew.

1. Drill dimples located approximately half way down enclosure doors with an 11/32" bit.



2. Place black 5/16"-18 U-Type Clip Nut over enclosure flanges and align with factory-drilled hole in the flanges.



3. Place bolts into the drilled holes, apply retaining washers, and tighten with security key.

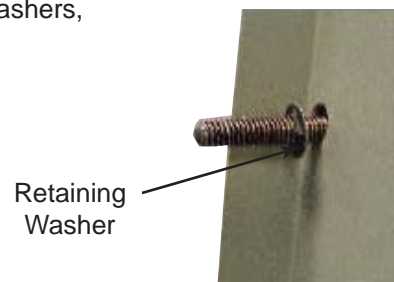

5.0 PN Series Options, continued

5.2 Battery Interface Unit (BIU)

The BIU is used in Powernode systems with multiple power supplies or multiple battery strings, and an AlphaGen DC generator. The BIU provides a parallel DC bus with convenient connectors for each power supply and battery string.

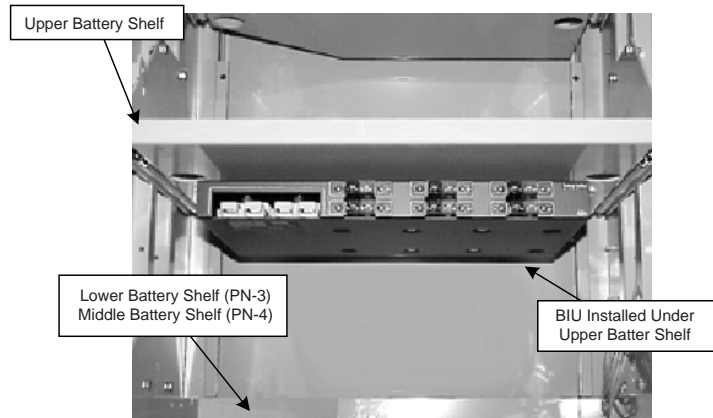

Fig. 5-1, Battery Interface Unit Installed

5.3 Service Disconnects

There are four Service Disconnects available (installed at the factory):

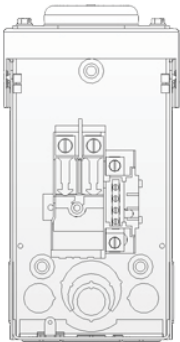

Fig. 5-2, BBX 70A (BBX-F12)
Square-D, 2-position
For single power supply
applications

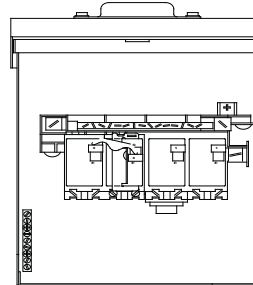

Fig. 5-3, BBX 100A (BBX-F18)
Square-D, 8-position
For multiple power supply
applications

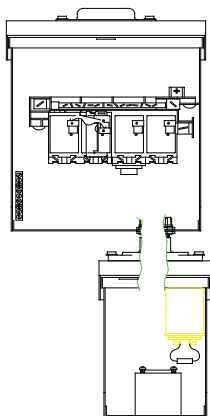

Fig. 5-4, MTS
(Showing 100A and 60A boxes)
For applications requiring
a protected AC generator

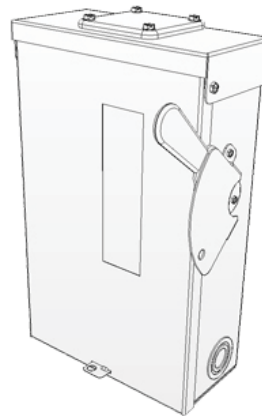

Fig. 5-5, FBX 60A
For multiple power supply
applications

5.0 PN Series Options, continued

5.4 Input Power Panel (IPP)

There are four basic configurations of the IPP. Each is available in 120V and 240V. Units in Figs 5-6, 5-7, and 5-8 are factory pre-wired, include Square-D high-magnetic breakers for each power supply, and provide a GFCI convenience outlet.

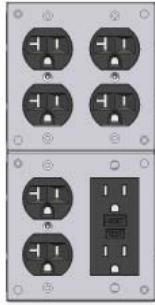

Fig. 5-6, IPP for Three Power Supplies



Fig. 5-7, IPP for Two Power Supplies

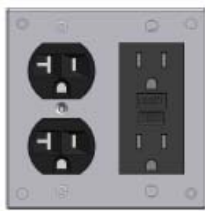

Fig. 5-8, IPP for One Power Supply



Fig. 5-9, Breaker Duplex Option (BDO)
For single power supply
(NOT factory pre-wired)

5.5 Lightning Arrester (LA-P+)

The Lightning Arrester is available in 120Vac and 240Vac, and is installed by plugging it into an IPP or BDO. The unit is operating properly when the green LED is lit.



Fig. 5-10, LA-P+ Installed in BDO



Fig. 5-11, Location of LED on LA-P+

5.0 PN Series Options, continued

5.6 Cooling Fan Kit

When using more than one power supply in the PN Series Enclosures, a cooling fan is required. The Cooling Fan kit includes an intake filter, located inside the front door of the enclosure by the ventilation louvers. The filter must be cleaned periodically as part of the power supply preventative maintenance program.

Replacement fuses and filters are available. Refer to Section 6.0 for part numbers.



Fig. 5-12, Cooling Fan Panel

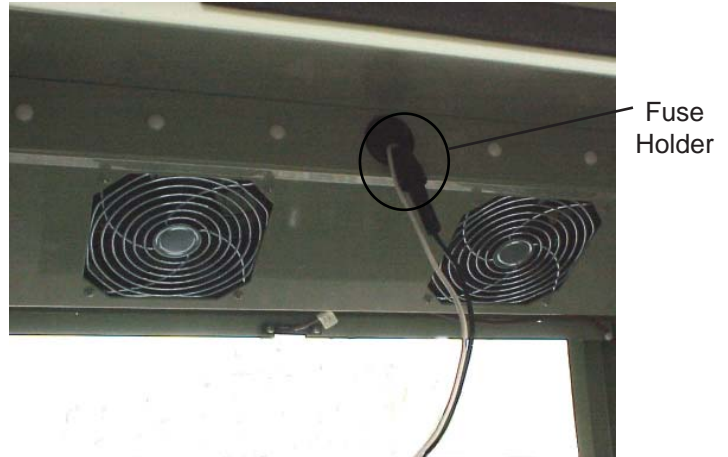

Fig. 5-13, Panel Installed in Top Rear of Enclosure



Fig. 5-14, Cooling Fan Plugged into Power Supply and SPI



CAUTION!

The input voltage of the AutoTransformer must match the output voltage of the power supply. Incorrect input voltage can cause the transformer to overheat and fail, or underpower the fans resulting in degraded cooling performance.

6.0 Alpha Part Numbers

Item:	Part Number:
Star Lock Security Bolt	744-897-20
Security Key	647-089-10
Battery Interface Unit (BIU)	018-311-24
Service Disconnects	
BBX-70A	744-656-20
BBX-100A-8POS	744-657-20
MTS 240-40	SPB99-512-12
FBX-60A	744-534-20
Input Power Panels (IPP) (Pre-Wired)	
IPP-CE, 1x240 1xGFCI	744-735-20
IPP-CE, 2x240 1xGFCI	744-701-20
IPP-CE, 3x240 1xGFCI	744-868-20
IPP-CE3x9x 120V for BATT HTR	744-702-20
IPP-CE, 1x120 1xGFCI	744-735-21
IPP-CE, 2x120 1xGFCI	744-701-22
IPP-CE, 3x120 1xGFCI	744-868-21
IPP-CE, 3x120 1xGFCI 120Vin	744-868-22
BDO (NOT installed)	
BDO-515 120V 15A Not SUSE Rated	744-148-20
BDO-520 120V 20A Not SUSE Rated	744-148-21
BDO-615 240V 15A Not SUSE Rated	744-147-21
Cooling Fan Kit	744-839-20
Replacement Fuse	460-025-10
Lightning Arrester	
LA-P+ 120V (L-N, L-G, N-G)	020-098-24
LA-PC+ 120V (L-N, L-G, N-G)	020-098-26
LA-PE+ 240V (L1-L2, L1-G, L2-G)	020-098-25
Extra SPI (15 Amp)	744-279-22
Extra SPI (25 Amp)	744-789-21
Filter, Electrostatic, 12" X 16" X 1"	561-234-10

 **NOTE:**

Alpha part numbers are correct at the time of printing. As part numbers are subject to change, please contact your Alpha Representative prior to ordering to ensure that numbers are correct.

7.0 Pre-cast Pads

Alpha offers a line or precast, polymer concrete, and reinforced concrete pads for the PN Series Enclosures. Polymer concrete is significantly lighter and more stable when compared to reinforced concrete. Both materials represent a significant savings in labor costs, and quality improvement over "pour-in-place" pads. Other precast pad configurations are available. Contact your nearest Alpha representative for additional information.

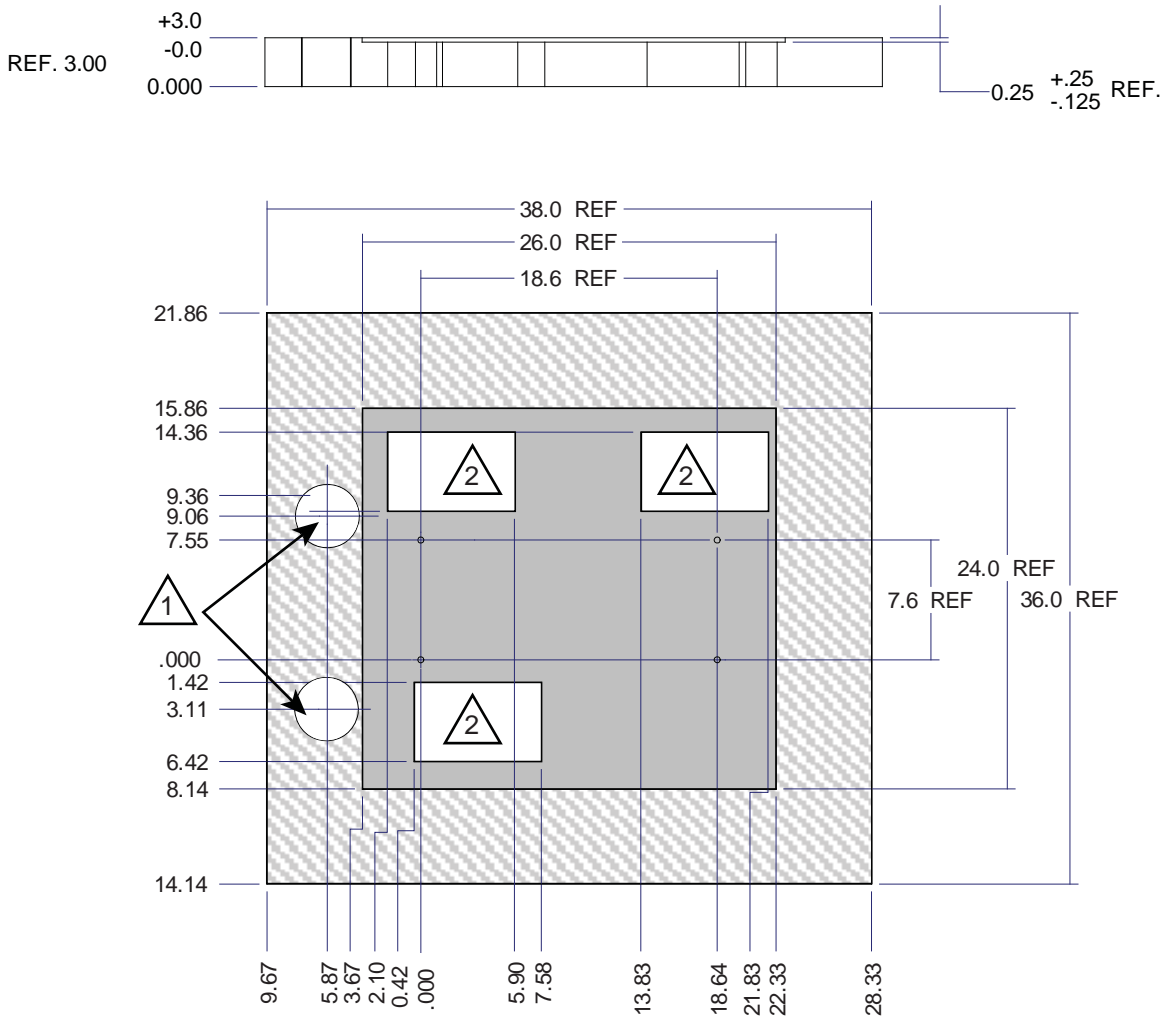



Fig. 7-1, Single-wide Pad, for PN 3/4
 Part Number:
 PCD-3: 641-070-10 (Reinforced concrete)
 PCC-3: 641-067-10 (Polymer concrete)

-  4" diameter opening (2 places).
-  5" x 8" opening (3 places).

7.0 Pre-cast Pads, continued

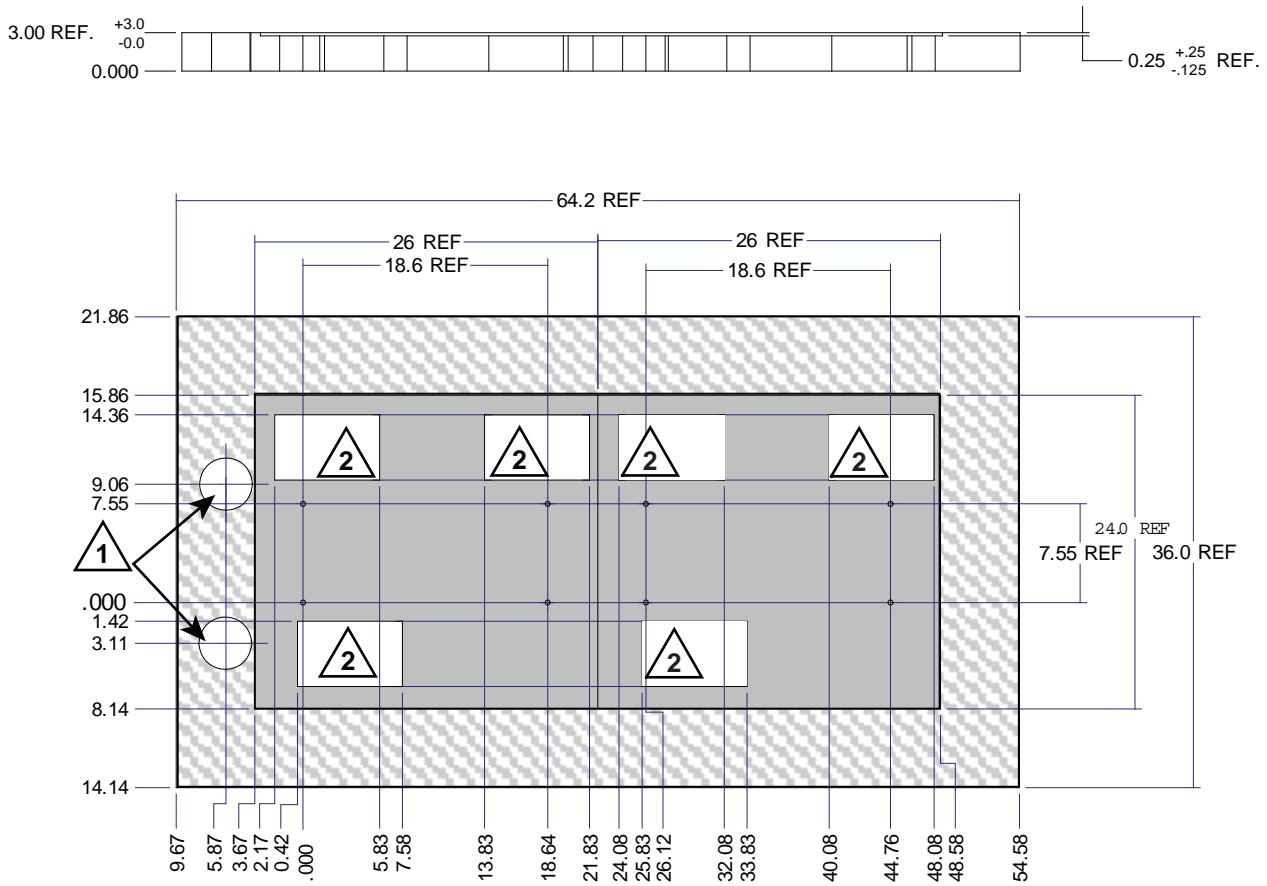



Fig. 7-2, Double-wide Pad, for PN 3/4

Part Number:

PCD 3-3: 641-072-10 (Reinforced concrete)

PCC 3-3: 641-069-10 (Polymer concrete)

 4" diameter opening (2 places).

 5" x 8" opening (6 places).

7.0 Pre-cast Pads, continued

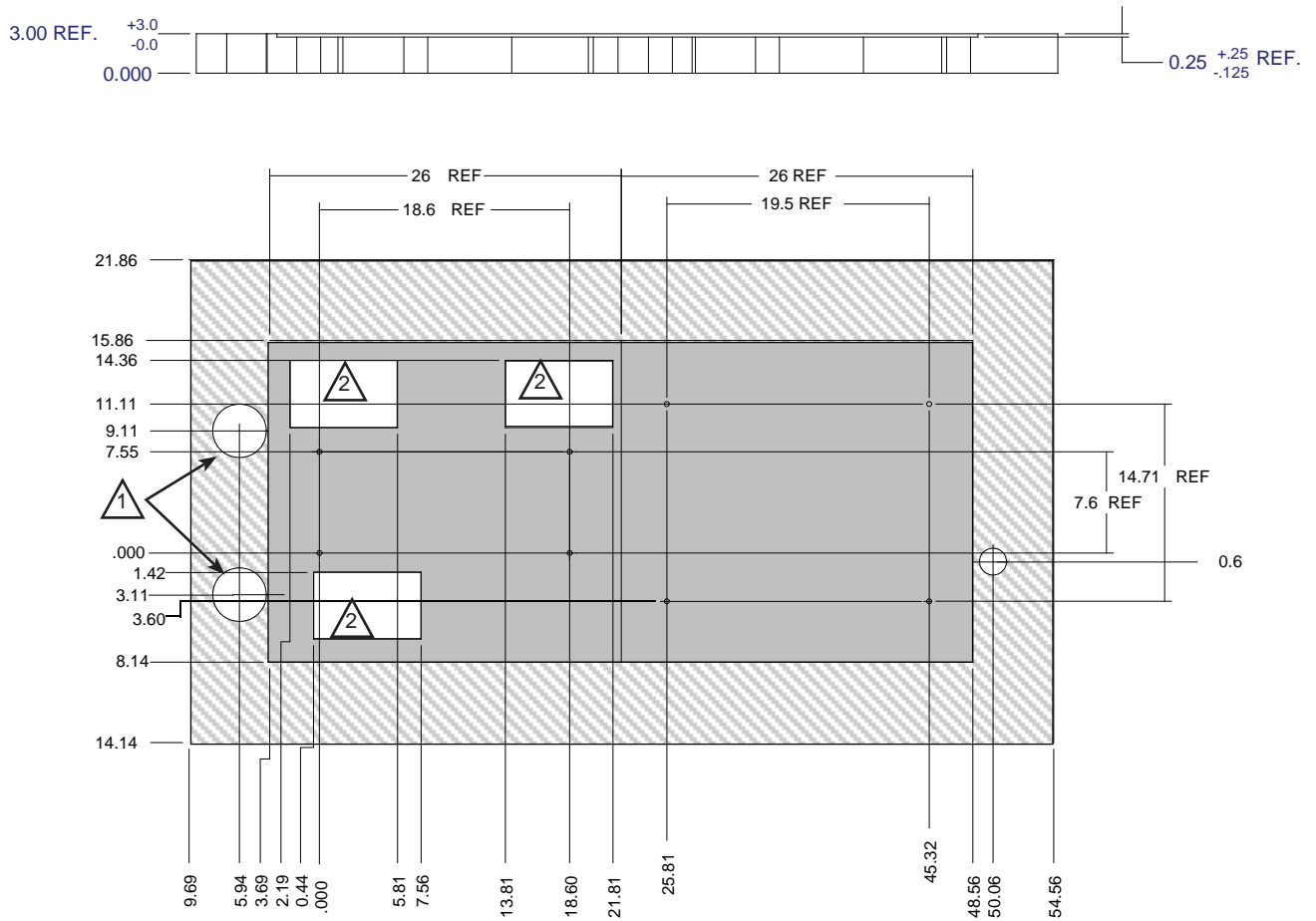



Fig. 7-3, Double-wide Pad, for CE 3x2/9x2 and CE8/9 or PN 3/4

Part Number:

PCD 3-3x: 641-071-10

PCD 3-3x: 641-068-10

-  4" diameter opening (2 places).
-  5" x 8" opening (3 places).

Power

Alpha Technologies 

Alpha Technologies
3767 Alpha Way
Bellingham, WA 98226
USA
Tel: +1 360 647 2360
Fax: +1 360 671 4936
Web: www.alpha.com

Alpha Technologies Ltd.
4084 McConnell Court
Burnaby, BC, V5A 3N7
CANADA
Tel: +1 604 430 1476
Fax: +1 604 430 8908

Alpha Technologies
Europe Ltd.
Twyford House
Thorley
Bishop's Stortford
Hertfordshire
CM22 7PA
UNITED KINGDOM
Tel: +44 0 1279 501110
Fax: +44 0 1279 659870

Alpha Technologies GmbH
Hansastraße 8
D 91126 Schwabach
GERMANY
Tel: +49 9122 79889 0
Fax: +49 9122 79889 21

Alphatec, Ltd
P.O. Box 56468
Limassol, Cyprus
CYPRUS
Tel: +357 25 375675
Fax: +357 25 359595

AlphaTEK ooo
Khokhlovskiy Pereulok 16
Stroenie 1, Office 403
109028 Moscow
RUSSIA
Tel: +7 495 916 1854
Fax: +7 495 916 1349

Alphatec Baltics
S. Konarskio G. 48
2009 Vilnius
LITHUANIA
Tel: +370 5 213 8822
Fax: +370 5 213 7799

Alpha Technologies
9, Impasse Sans Souci
92140 Clamart France
FRANCE
Tel: +33 141 900 707
Fax: +33 141 909 312