

External Security Bar and Clasp Cover Field Installation Instructions

The External Security Bar (ESB) mounts to PWE-3, PWE-6, PWE-6FT, CESC-HS and U-GEM enclosures. The ESB is made from high grade stainless steel, providing corrosion resistance, physical security, and a strong visual deterrent. Add the optional Clasp Cover for additional protection to the padlock and clasp area. The Clasp Cover, made of high grade stainless steel, fully conceals the clasp and padlock and is secured with a keyed security screw to prevent tampering.



WARNING! ELECTRICAL HAZARD

Before drilling, clear all equipment and wiring from the enclosure.

Tools Required:

- 3/8" drive hand drill
- 9/32" (#K) drill bit
- 7/16" nut driver or socket

Materials List, Enhanced ESB		Installation kit for PWE-3, PWE-6, CESC-HS 746-625-20	Installation kit for PWE-6FT 746-148-24	Installation kit for U-GEM 746-148-27
Alpha P/N	Description	Qty*	Qty	Qty
605-972-G1	Bracket, Lock	1	1	1
605-973-G1	Backing Plate, Lock	1	1	2
605-974-G1	Backing Plate, Hinge	1	1	2
606-972-G1	Bracket, Bar	1	-	1
606-229-G1	Bracket, Bar	-	1	-
630-109-12	Bolts, 1/4-20 x 3/4"	6	6	6
633-013-12	Flat Washers	6	6	6
634-059-12	KEPS Hex Nuts, 1/4-20	6	6	6

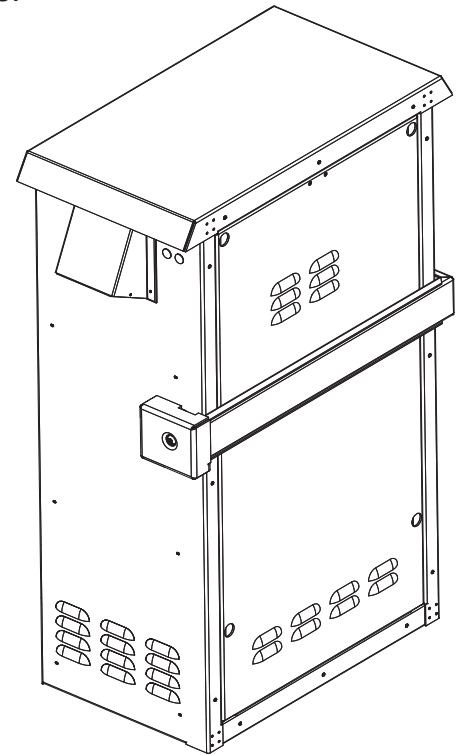

CESSC-HS Enclosure with ESB and Optional Clasp Cover

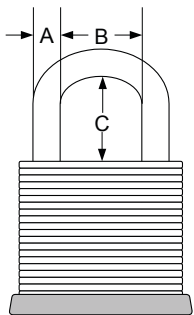

In addition:
A security lock (e.g., Master® Lock No. 3 or equivalent) is required to secure the enclosure. The user-supplied lock must meet the following dimensions.

A = 9/32" (7mm) B = 5/8" (16mm) C = 3/4" (19mm)



Bracket, Bar

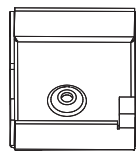

Bracket, Lock



Backing Plate(s)
Lock



Backing Plate(s)
Hinge

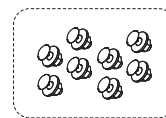

Mounting Hardware
(in plastic bag)

Fig. 1, External Security Bar and Optional Clasp Cover Kit

Dimensions and Specifications



NOTE:

Dimensions are taken from the bottom front corner(s) of the enclosure.

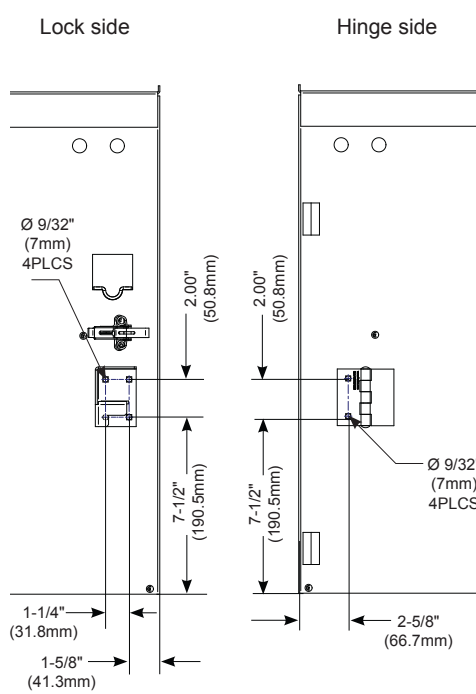

Fig. 2, PWE-3 Enclosure

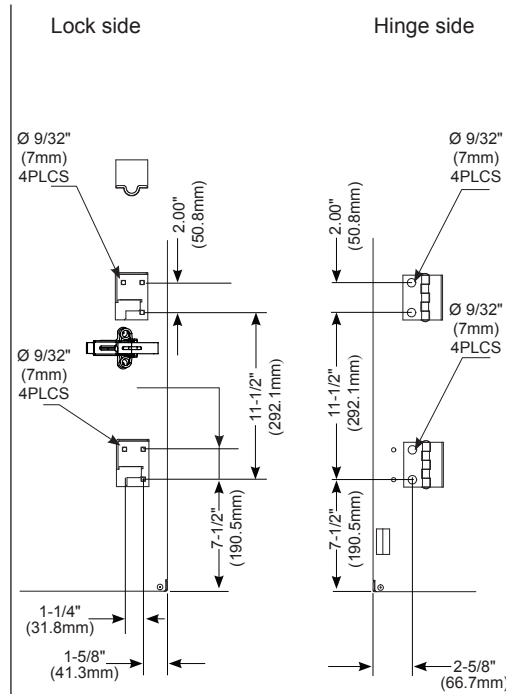

Fig. 3, PWE-6 Enclosure

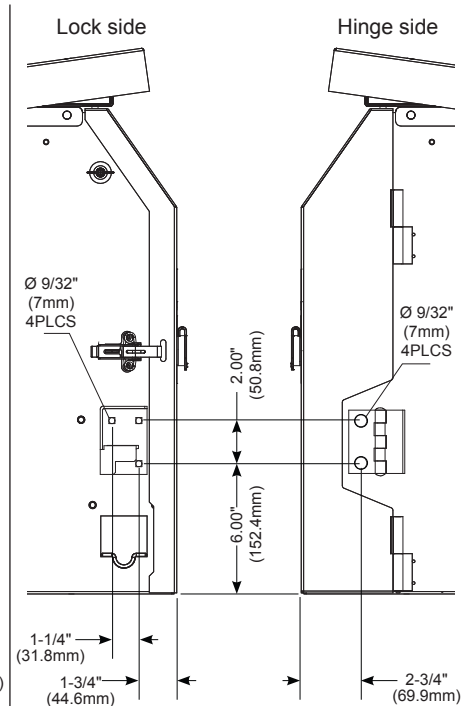

Fig. 4, U-GEM Enclosure

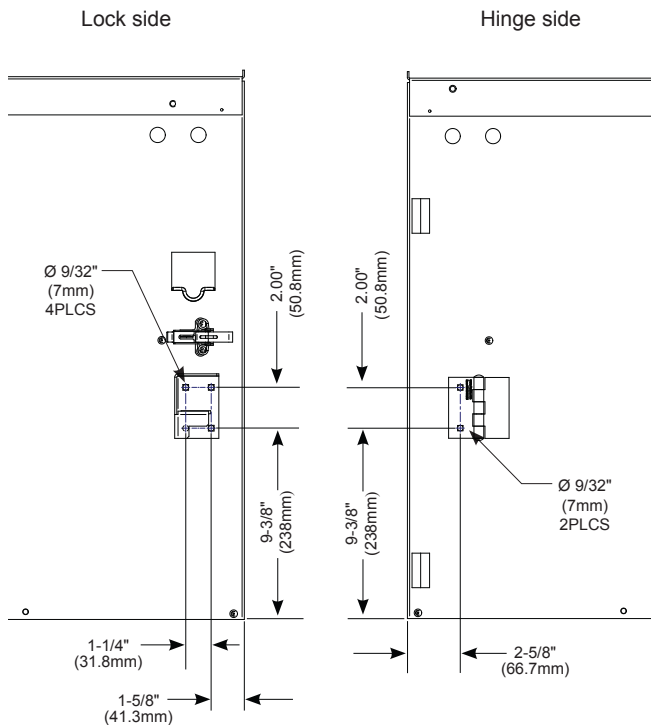

Fig. 5, PWE-6FT Enclosure

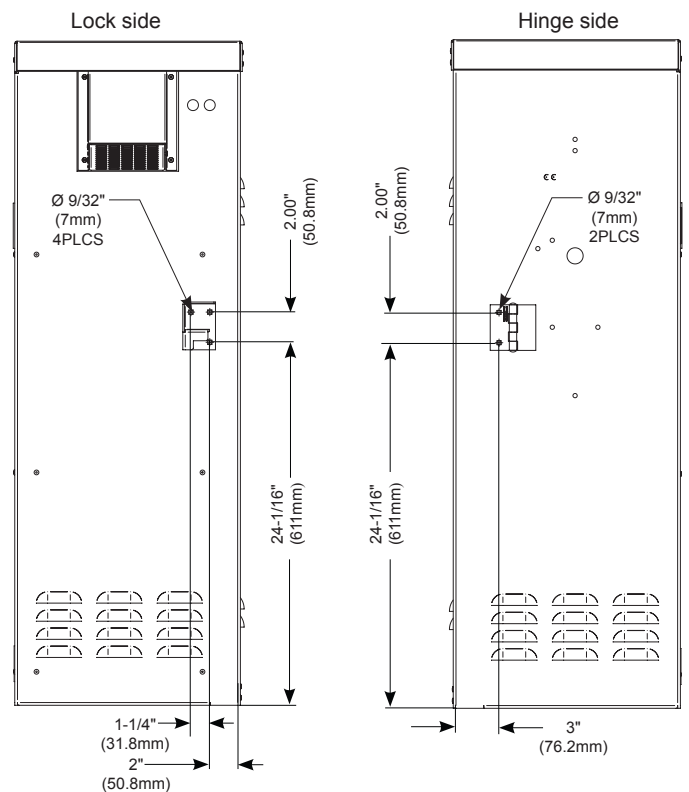

Fig. 6, CESC-HS Enclosure

Installing the Security Bar

1. Refer to the appropriate figures on the previous page for the application (Figures 1 through 5) for accurate measurements.



NOTE:

Legacy enclosures will not have knockouts in this area.

2. Mark and drill the two (2) mounting holes for the hinged (right) end of the security bar. Use the hardware provided to secure the bracket to the enclosure.
3. Mark and drill the four (4) mounting holes for the lock bracket. Use the hardware provided to secure the bracket and backing plate to the enclosure.
4. The enhanced security bar is ready for use. Close and fasten the security bar using an appropriate lock (Master® Lock No. 3 or equivalent).



NOTE:

The U-GEM enclosure application requires installation of two (2) backing plates, one inside and one outside of the enclosure, on both the lock and hinge side.

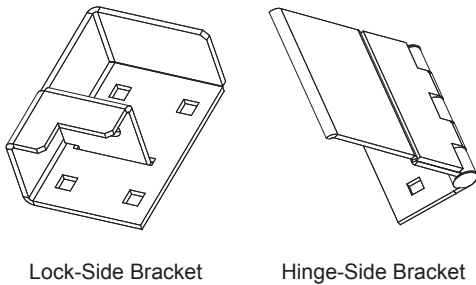
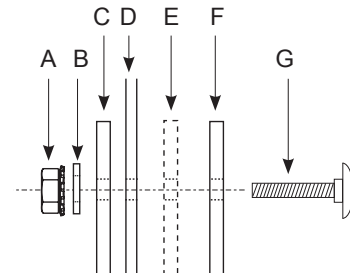

Fig. 7, Brackets



- A 1/4"-20 KEPS Hex Nut
- B Flat Washer
- C Internal Stainless Steel Backing Plate
- D Enclosure Wall
- E External Stainless Steel Backing Plate (for Gem Enclosure applications only)
- F Outer Bracket (hinge on right side; lock cover, left side)
- G 1/4-20 x 3/4" Carriage Bolt

Fig. 8, Hardware Stack-Up

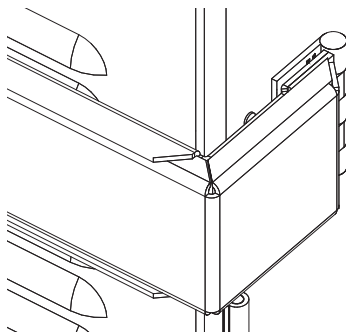

Fig. 9, Right Side

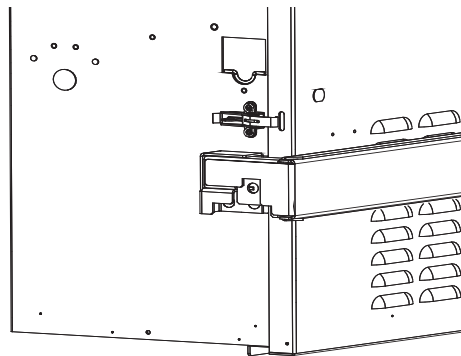

Fig. 10, Left Side

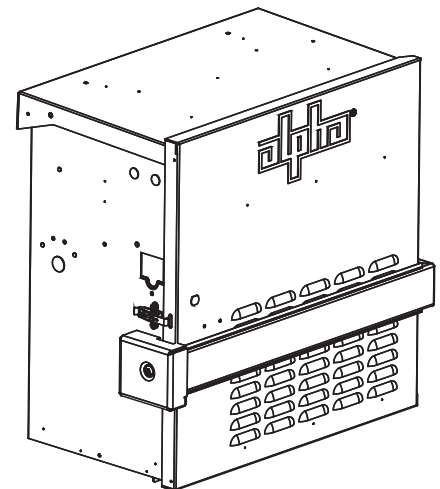

Fig. 11, Front View
(shown with optional cover)

Installing the Clasp Cover (Optional – sold separately)

Materials List		
Clasp Cover Kit (with Security Screw) — 746-293-20		
Clasp Cover Kit (without Security Screw) — 746-293-21		
Alpha P/N	Description	Qty*
606-199-G1	Lock Cover	1
634-491-10	U-Nut, 5/16"	1
647-189-11	Alpha -01 Security Screws	1**
647-188-10	Alpha -01 Security Key	0***

* Note: part quantities will be doubled when ordering the PHSD for a PWE-6 enclosure.

** Optional: Customer may supply their own security screws.

***Note: Not included, but required for Alpha -01 security screws.

For existing security bars, installed prior to 2012, locate and drill hole as described below.

Mark and drill a 17/32" hole over the locking (left) side of the bracket as shown. (Alpha recommends creating two pilot holes: one small, then one medium before drilling the final hole to reduce wear on drill bits.)

Assembling the Clasp Cover

Tools: Torque wrench and socket to fit the security key.

Slide the U-Nut over the hole as shown (Fig. 13). Place the lock cover and secure with security screw tightened to a torque of 13.5 ft-lb (18.3 Nm).

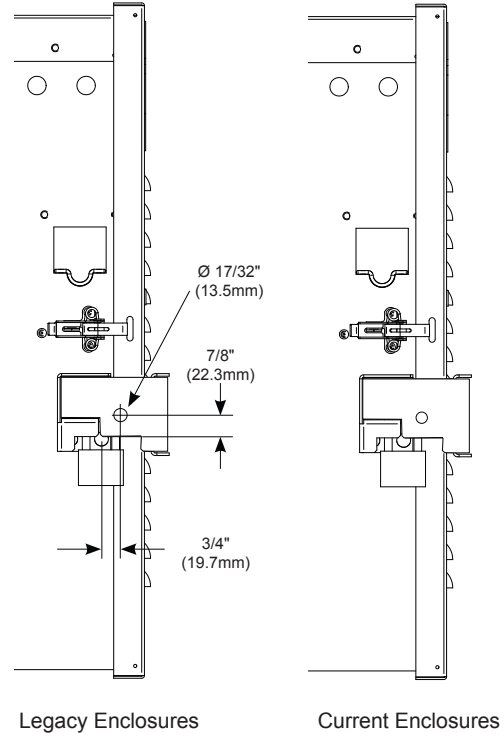

Fig. 12, U-Nut Mounting Hole Locations

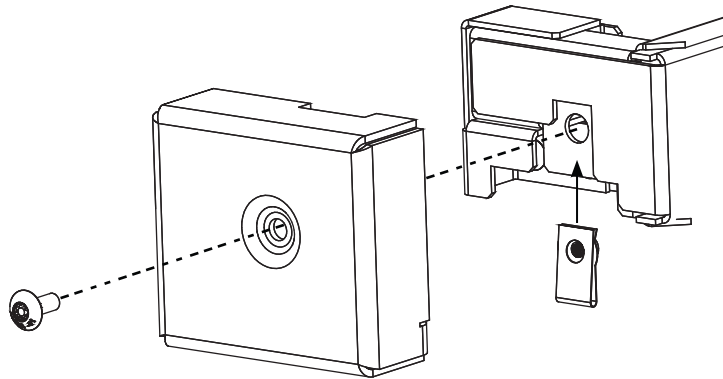

Fig. 13, U Nut, Lock Cover and Security Screw Stack-Up

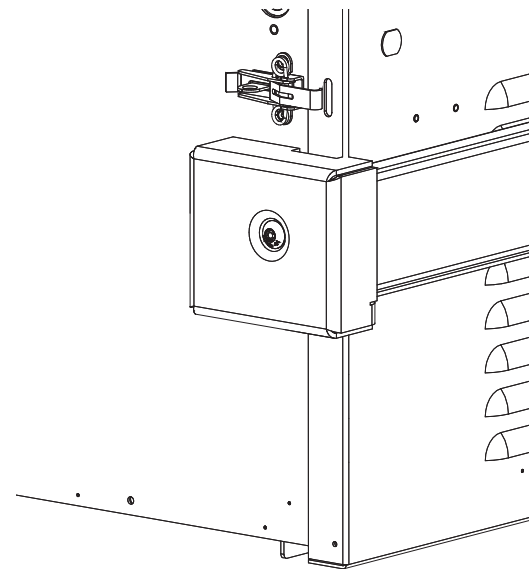

Fig. 14, Completed Assembly

Worldwide Corporate Offices

North America

Tel: +1 360 647 2360
Fax: +1 360 671 4936

Europe

Tel: +49 9122 79889 0
Fax: +49 9122 79889 21

Latin America

Tel: +561 792.9651
Fax: +561 792.7157

Asia Pacific

Tel: +852 2736.8663
Fax: +852 2199.7988