



## Battery Monitoring Device



# OWNER'S MANUAL



[www.enersys.com](http://www.enersys.com)

# CONTENTS

<b>Introduction .....</b>	<b>3</b>
<b>Features .....</b>	<b>4</b>
<b>Technical Specifications .....</b>	<b>4</b>
<b>Dimensions .....</b>	<b>8</b>
<b>Installation .....</b>	<b>9</b>
<b>Communication .....</b>	<b>9</b>
<b>Service and Troubleshooting ....</b>	<b>16</b>



# INTRODUCTION



The information contained in this document is critical for safe handling and proper use of the Wi-iQ<sup>®</sup>4 battery monitoring device. It contains a global system specification as well as related safety measures, codes of behavior, a guideline for commissioning and recommended maintenance. This document must be retained and available for users working with and responsible for the battery monitoring device. All users are responsible for ensuring that all applications of the system are appropriate and safe, based on conditions anticipated or encountered during operation.

This owner's manual contains important safety instructions. Read and understand the sections on safety and operation of the battery monitoring device before operating the battery monitoring device and the equipment into which it is installed.

It is the owner's responsibility to ensure the use of the documentation and any activities related thereto, and to follow all legal requirements applicable to themselves and the applications in the respective countries.

This owner's manual is not intended to substitute for any training on handling and operating the Wi-iQ<sup>®</sup>4 battery monitoring device that may be required by local laws and/or industry standards. Proper instruction and training of all users must be ensured prior to any contact with the battery system.

**For service, contact your sales representative or call:**

**EnerSys<sup>®</sup> EMEA**  
EH Europe GmbH  
Baarerstrasse 18  
6300 Zug, Switzerland  
Tel: +41 44 215 74 10

**EnerSys APAC**  
No. 85, Tuas Avenue 1  
Singapore 639518  
+65 6558 7333

[www.enersys.com](http://www.enersys.com)

**Your Safety and the Safety of others is Very Important**

**⚠ WARNING** You can be killed or seriously injured if you don't follow these instructions.

# FEATURES & SPECIFICATIONS

## Features

The Wi-iQ<sup>®</sup>4 battery monitoring device is the fourth generation of battery sensor technology, providing incremental features such as Bluetooth and

CAN-Bus connectivity to improve communication and integration with other devices and external equipment. Features added to the new compact design include three LEDs to communicate status, a new LCD display to show important battery information, and an audible alarm.

- Programmable
- Wi-iQ<sup>®</sup>4 device is available in 2 configurations; it can be assembled on batteries from 24V to 80V and 96V to 120V
- Small and slim fit
- IP65 enclosure
- Available for flooded lead-acid and NexSys<sup>®</sup> TPPL battery chemistries
- Single or dual cable current sensors
- LCD display and low voltage alarm buzzer
- Memory capable of more than 8,000 events
- Multiple communication channels
  - Zigbee<sup>®</sup> wireless to Wi-iQ<sup>®</sup> Report PC software and charger
  - Bluetooth to E Connect<sup>™</sup> mobile app and Truck IQ<sup>™</sup> smart battery dashboard

- The newly designed E Connect<sup>™</sup> mobile app enables fast and easy checkup of battery fleet and data sharing
- Connection with our external Truck IQ<sup>™</sup> device that shows real time data to the operator about battery status, alarms and remaining working time
- Optional CAN-Bus module provides State of Charge (SoC) and other data to any CAN network (e.g. lift trucks, AGVs)
- Compatible with Xinx<sup>™</sup> warehouse management efficiency system to simplify both data collection and reporting
- Wireless communication with our modular charger allows for better asset control
- Adjustable SoC warning and provides an audible alarm
- Eliminates need for separate Low Voltage Alarm (LVA) device

**NOTE:** The Wi-iQ<sup>®</sup>4 device is designed to be installed only on a battery and will not function properly if mounted on the truck side of battery connector for a power study.

## Technical Specifications

Item	Description
Nominal Battery Voltage	24VDC to 80VDC and 96VDC to 120VDC
Operating Voltage	24VDC to 80VDC and 96VDC to 120VDC
Operating Temperature	4°F (-20°C) – 140°F (60°C)
Bi-directional Current Measurement	Allows for throughput data collection using a Hall effect sensor which can measure up to +/- 1000A. 1A resolution
Voltage Measurement	Continuous monitoring of overall battery voltage and half battery voltage
Voltage Accuracy	0.1V
Temperature	External thermistor
Altitude	<2,000m (<6,561ft)
Electrolyte Level Detection	With electrolyte sensor

Item	Description
Wireless Interface	Zigbee (SMAC -2.4Ghz), Bluetooth BLE
Real Time Clock	Timekeeping and stamping of data
Data Storage	Upload data to PC via dongle, to cloud server via E Connect mobile app
Data Collection	Up to 8,000 event log records
Wireless Range	Up to 10m (32ft) (Zigbee); up to 5m (16ft) (BLE)
CAN Communication	2 different CAN protocols: CANopen or J1939
Power Consumption	1 Watt
Protection	Over voltage Reverse polarity protection
Packaging	Water- and acid-resistant UL 94V-0 Pollution level 3 protection (dusty environment) IP65 enclosure

# TECHNICAL SPECIFICATIONS

## Technical Specifications (cont.)

Item	Description
Physical Dimensions	40,07mm L x 19,5 mm W x 107,97mm H
Compliance	<b>Electrical Equipment (Safety) Regulations 2016 (S.I. 2016/1101) Directive 2014/35/EU :</b> Safety BS EN 61010-1 : 2010 / A1 : 2019 <b>EMC Regulations 2016 (S.I.2016/1091) Directive 2014/30/EU :</b> Electromagnetic compatibility BS EN 12895 : 2015 / A1 : 2019 <b>Directive 2011/65/EU</b> RoHS <b>Radio Equipment Regulations 2017 (S.I.2017/1206) Directive 2014/53/EU</b> ETSI EN 301 489-1 V2.2.3 (2019) ETSI EN 301 489-17 V3.2.2 (2019) ETSI EN 300 328 V2.2.2 (2019)



Figure 1

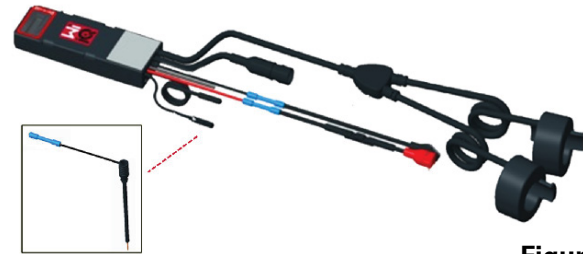

Figure 2

THIS DEVICE COMPLIES WITH PART 15 OF THE FCC RULES. OPERATION IS SUBJECT TO THE FOLLOWING TWO CONDITIONS:

(1) THIS DEVICE MAY NOT CAUSE HARMFUL INTERFERENCE

(2) THIS DEVICE MUST ACCEPT ANY INTERFERENCE RECEIVED, INCLUDING INTERFERENCE THAT MAY CAUSE UNDESIRABLE OPERATION.

FOLLOWING FCC REQUIREMENTS, CHANGES OR MODIFICATIONS NOT EXPRESSLY APPROVED BY ENERSYS COULD VOID THE USER'S AUTHORITY TO OPERATE THIS PRODUCT.

**Technical support:** Reference [www.enersys.com](http://www.enersys.com) to find your local contact.

### Components

**Figure 1:** Wi-iQ<sup>®</sup>4 Device for Flooded Batteries with Electrolyte Probe

### The Wi-iQ<sup>®</sup>4 Battery Monitoring Device

The Wi-iQ<sup>®</sup>4 battery monitoring device consists of:

A main unit (for voltage measurement, display, LEDs, buzzer, and communication features)

- 1 or 2 current sensors
- A CAN connection (use is optional)
- Red/black cables to power the Wi-iQ<sup>®</sup>4 device
- Balance/gray wire for mid-battery voltage (with a fuse)
- Temperature probe
- Electrolyte level probe for flooded battery version

- 3 crimping splices + 3 cable ties
- Installation hardware

**Figure 2:** Wi-iQ<sup>®</sup>4 Device for Thin Plate Pure Lead (TPPL) or Valve Regulated Lead Acid (VRLA) with CAN Connector; without Electrolyte Probe

### The Wi-iQ<sup>®</sup>4 Device Part Numbers

There are six part numbers available.

Part Number	Reference P/N	Description	Battery Type
<b>Wi-iQ<sup>®</sup>4 120V SGL</b>	GL0017459-0002	Wi-iQ <sup>®</sup> 4 monitor Premium CAN single sensor	All with CAN
<b>Wi-iQ<sup>®</sup>4 120V DBL</b>	GL0017459-0007	Wi-iQ <sup>®</sup> 4 monitor Premium CAN dual sensor	All with CAN
<b>Wi-iQ<sup>®</sup>4</b>	6LA20743-E0E	Wi-iQ <sup>®</sup> 4 monitor Basic flooded single sensor	Flooded
<b>Wi-iQ<sup>®</sup>4</b>	6LA20743-E3E	Wi-iQ <sup>®</sup> 4 monitor Basic VRLA single sensor	Gel, TPPL
<b>Wi-iQ<sup>®</sup>4F</b>	6LA20743-E1E	Wi-iQ <sup>®</sup> 4 monitor Premium CAN single sensor	All with CAN 24V up to 80V
<b>Wi-iQ<sup>®</sup>4DUALF</b>	6LA20743-E2E	Wi-iQ <sup>®</sup> 4 monitor Premium CAN dual sensor	All with CAN 24V up to 80V
<b>6LA20761</b>	6LA20761	Electrolyte sensor (replacement part only) used only for flooded batteries	Flooded

# TECHNICAL SPECIFICATIONS

## Technical Specifications (cont.)

### The Wi-iQ<sup>®</sup>4 Device Display and LEDs

An LCD display and three LEDs on the Wi-iQ<sup>®</sup>4 device provides status indication. The display is turned OFF after 15 minutes of no activity (sleep mode). A small touch to the Wi-iQ<sup>®</sup>4 device display will turn the display back ON.

Figure 3: Display and LEDs

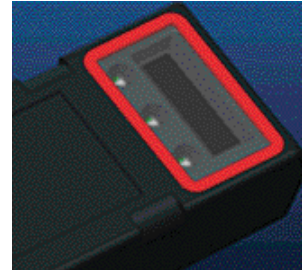

Figure 3

### Parameters

Description	Value	Comment
<b>SoC</b>	0-100%	State of Charge of the battery
<b>Battery Voltage</b>	Ex: 27.2V	Overall battery voltage (V)
<b>Temperature</b>	Ex: 64°F (18°C)	Battery Temperature
<b>Current</b>	Ex: 10.4A	Current value in A (+ charge, - discharge)
<b>Bluetooth Connected</b>		When the smartphone is connected to the Wi-iQ <sup>®</sup> 4 device
<b>Warning</b>	Level	Blue LED ON
	Temperature	Red LED Flashing or ON
	Low SoC Warning	Buzzer ON
	Low SoC Alert	
	Unbalance	Blue LED flashing
	No Current Sensor	CURRENT/SENSOR NO/SIGNAL
	No Temperature Sensor	TEMP/SENSOR NO/SIGNAL

### Colors and Functions

LED	Color	Lit	Blinking (0.5s ON / 0.5s OFF)
Left	Red	High Temperature	Warning Temperature
Center	Orange	Alert SoC	Warning SoC
Right	Blue	Low level	Unbalance
	All	Short blink (0.5 s) every 5 seconds	

**NOTE:** When the Wi-iQ<sup>®</sup>4 device is first connected to the battery voltage, all LEDs are flashing and firmware revision is shown on the display (initialization sequence). The SoC shown will be a reloaded value from the manufacturer. To start, please set the device and reset the value (refer to the configuration section of the manual).

### Buzzer

There is a buzzer located inside the main unit. The buzzer is activated when the SoC of the battery is low and the battery needs to be charged. Reference Default Value of the Buzzer vs. Battery Type table.

### Warning and Alert Time Frequency

	Normal SoC	Warning SoC	Alert SoC
<b>Buzzer</b>	OFF	2 chirps every 20 seconds	1 chirp every 5 seconds

### Default Value of the Buzzer vs. Battery Type

Battery Type*	Warning SoC	Alert SoC
NexSys TPPL NXS models	30%	20%
NexSys TPPL NXP models	50%	40%
Others	30%	20%

\*Adjustable

### The Wi-iQ<sup>®</sup>4 Device Current Sensor(s)

The current sensor is a solid core Hall effect device.

### Current Sensor Technical Specification

DC Cable Gauge	AWG	Internal Diameter	Truck Class Recommendation	Max DC Current
Up to 120mm <sup>2</sup>	Up to 4/0	20.1 mm	Class 1, 2 & 3	1000A

**NOTE:** The DC cable gauge does not consider the terminal lug or contact dimensions. Terminal lugs or contacts may need to be assembled after inserting the cable into the current sensor, mostly for the 4/0 cables.

# TECHNICAL SPECIFICATIONS

## Technical Specifications (cont.)

### Wi-iQ<sup>®</sup>4 Device CAN Option

If equipped, the Wi-iQ<sup>®</sup>4 device communicates via CAN protocol.

The Wi-iQ<sup>®</sup>4 device main unit is delivered with a protective plastic cap that needs to be removed to use the CAN option.

- J1939
- The CAN female connector pinout is described in **Figure 4**

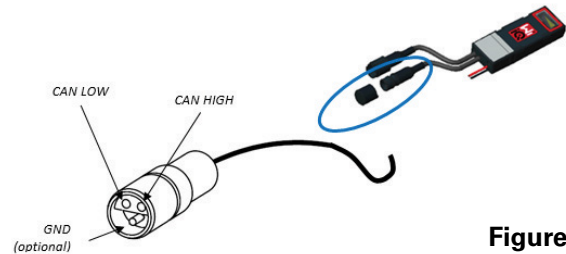

**Figure 4**

### Figure 4: Female Connector.

- The male connector is NOT included (ITT-CANON SURE-SEAL IP68 3-contact receptacle with two pins and one socket adapted for 0.75-1.5mm<sup>2</sup> wires).

The Wi-iQ<sup>®</sup>4 device CAN communication adopts two different CAN protocols:

- CANopen
- J1939

Refer to the CAN (Controlled Area Network) Communication section for proper documentation.

### CAN Connector Specification

Product	Receptacle Manufacturer Part Number	Contact Manufacturer Part Number		
		Wire Gauge	Pin (qty 2)	Socket (qty 1)
ITT-CANON SURE-SEAL	120-8551-001 (SS3R)	0.5–1.0mm <sup>2</sup>	330-8672-001 (SS20)	031-8703-001 (SS20)
		0.75–1.5mm <sup>2</sup>	330-8672-000 (SS10)	031-8703-000 (SS10)

# DIMENSIONS

## Dimensions

Wi-iQ<sup>®</sup>4 Battery Monitoring Device and effect overall dimensions (mm)

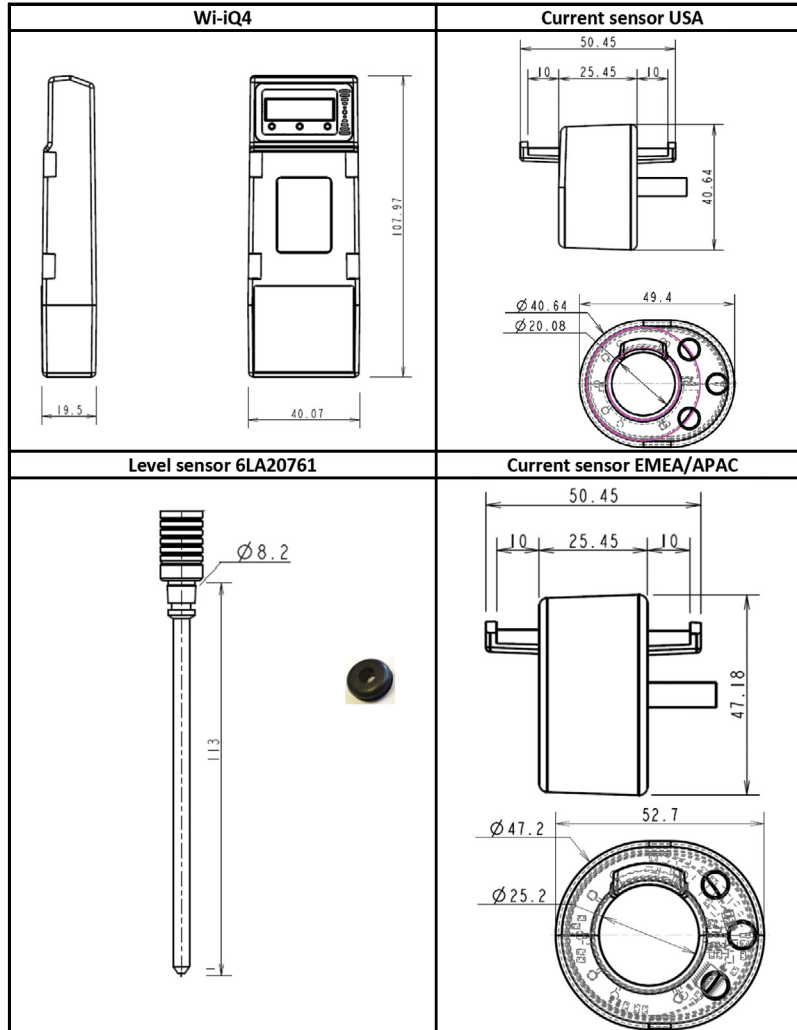

NB: All dimensions are given in mm.

### Probes and Sensors



Electrolyte Probe



Temperature Sensor



# INSTALLATION

## Installation

**Figure 5:** Wi-iQ<sup>®</sup>4 Device Final Assembly on 2V Cell Tray

**Figure 6:** Wi-iQ<sup>®</sup>4 Device Final Assembly on 12V Block Tray

**NOTE:** The stack order on the stud is: Battery Cable, Wi-iQ<sup>®</sup>4 Device Ring Terminal, Flat Washer, Lock Washer, and Nut.

- Ensure the threads on the nut and stud are clean, place a drop of blue Loctite™ on the stud, and tighten the nut in place.
- Torque the nut to the proper specification (**Figure 6**). Ensure the battery cable lug is flat against the plate.

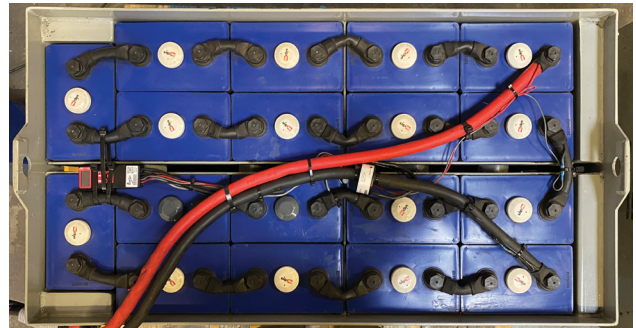

**Figure 5**

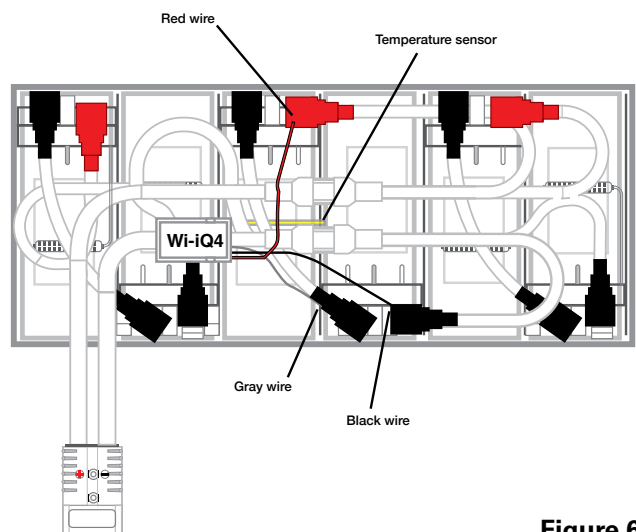

**Figure 6**

## Communication

There are two modes of communication (Wireless and CAN) available on the Wi-iQ<sup>®</sup>4 device:

### Wireless

- BLE
  - Connect to a smartphone via the E Connect™ mobile app
  - Connect to Truck iQ™ smart battery dashboard
- Zigbee® (legacy protocol in use with previous generations of Wi-iQ<sup>®</sup>4 devices)
- Connect to chargers (NexSys<sup>®</sup>+ battery charger)
- Connect to Wi-iQ<sup>®</sup> Report software
- Connect to Xinx™ system

**The Wi-iQ<sup>®</sup>4 device can be configured and provide data via Zigbee® (Wi-iQ<sup>®</sup> Report v5.4.5 minimum) or BLE (E Connect™ app-v2.16 minimum).**

### CAN (Controller Area Network)

- CANopen Cia 418 or J1939
  - Interface with truck using an Original Equipment Manufacturer (OEM) proprietary CAN protocol implemented.
  - Interface with AGV using EnerSys<sup>®</sup> proprietary CAN protocol.

## Communication (cont.)

### Configuring Wi-iQ®4 Device within Wi-iQ® Report

- Once the device is installed, it must be set up in the software. Plug a dongle (Wi-iQ®4 device antenna) into the USB port of a PC with the Wi-iQ® Report installed. Start Wi-iQ® Report.
- Click on the Software menu item in the upper left corner; click “Language” and select “US” (not English). This is necessary to ensure all the battery technologies (Bat. Techno) are available later in the software setup.
- Create a new site if one does not already exist. The naming of the site is not important for installation purposes.

Figure 7: Wi-iQ® Report Configuration Page.

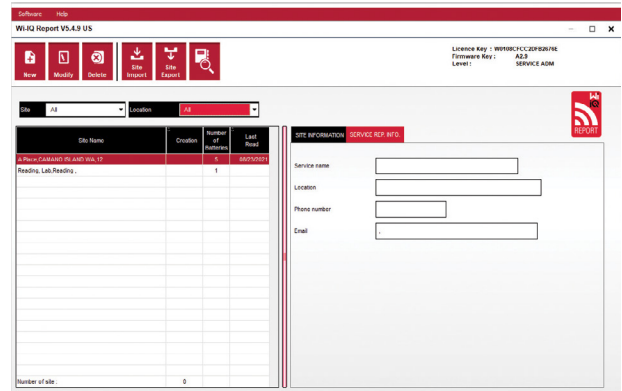

Figure 7

Double-click on the Site Name to open it. Previously added devices may be shown. To add a new device, click on the scan button at the top left. The software will scan for all available devices. Check the “Add” box for all devices you wish to configure and hit the “+ Add” button on the right. The devices can be identified by matching the Address (HEX) field to the S/N on the device.

Figure 8: HEX Address Match.

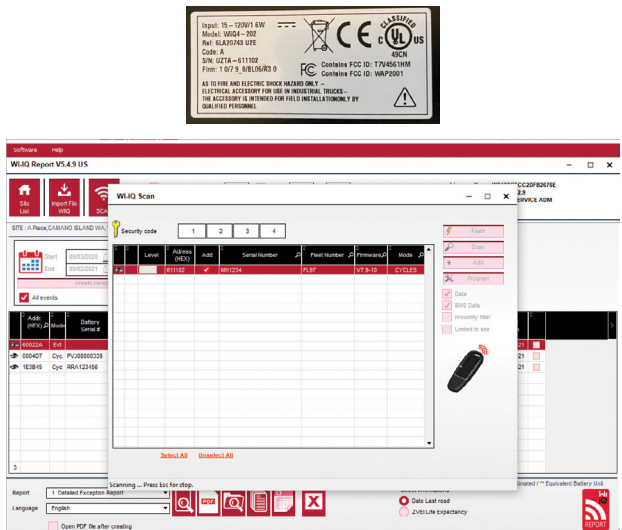

Figure 8

The devices you have added should now be added to the site view. If you have added multiple devices at once and you are unsure which device is on each battery, click on the eye icon in the left column. This will make all the LEDs on that device blink for 15 seconds. The device will also beep during the same period. Double-click anywhere along the line of the device you wish to configure to open the configuration window.

**NOTE:** If at any time the laptop version will not pick up the Wi-iQ®4 device or find the correct serial number of the device, configure it correctly through E Connect™ app on the appropriate serial number, scan it again and it will now show up in your Wi-iQ® Report on your laptop.

Figure 9: Wi-iQ® Report Homepage

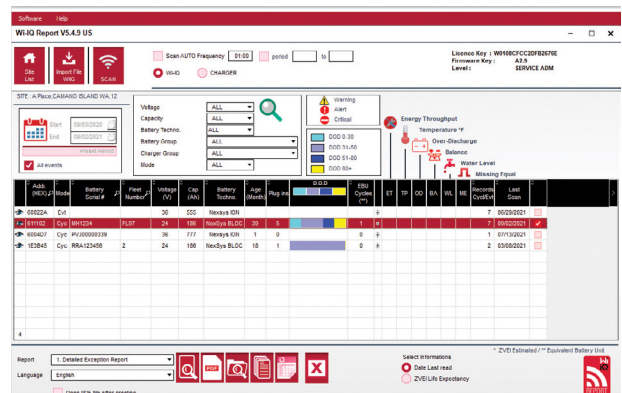

Figure 9

## Communication (cont.)

**Figure 10:** Wi-iQ® Report Device Configuration Page

**Battery SN#:** Enter the battery serial number (9 digits)  
**Fleet number:** As required  
**Model:** Enter the battery type, ex: 18-E100-21  
**Cells:** Enter the number of cells on the battery

**For NexSys® TPPL 2V batteries,** use total voltage divided by 2 to determine the number of cells. Example: The battery type is 36NXS700. 36 describes the total voltage of the battery. Take this number and divide by 2 to get “Cells”; in this example,  $36/2 = 18$  cells.

**Cells Bal.–**Enter the cell number where the gray wire was installed, counting from the positive post.

**For Nexsys® TPPL Bloc Battery:** The black Wi-iQ®4 device wire and the gray Wi-iQ®4 device wire should be attached to the negative and positive posts of the same bloc as described in the Installation section. In this configuration “Cells Bal.” will always be 6.

**Battery Technology –** Select the appropriate type of battery. Refer to line-item notes on BaaN order requesting any specific Battery Technology setting by the customer or sales representative. If nothing is requested in the line item notes, refer to the Charge Profiles Table.

### Charge Profiles

Battery Technology	Battery Types
AIR MIX	Flooded
FAST EU	Flooded
GEL	Evolution (PzV)
HDUTY	Flooded
NEXSYS 2V	Nexsys TPPL 2V (NXS)
NEXSYS BLOC	Nexsys TPPL Bloc (NXS)
NEXSYS PURE 2V	Nexsys TPPL (NXP)
NEXSYS PURE BLOC	Nexsys TPPL Bloc (NXP)
OPP	Flooded
PZQ	Ironclad (PzQ)
STDWL	Flooded
WL20	Waterless (PzM)



**Figure 10**

**Capacity (Ah):** Enter the nominal Ah of the battery.

- **Nexsys® TPPL Bloc Battery:** Determine total battery Ah. Example: 24-12NXS186-3. 186 describes the amp hour rating of each block and 3 describes the number of parallel strings. Multiply these two numbers to get “Capacity (Ah)”; in this example  $186 \times 3 = 558$  Ah.
- **Nexsys® TPPL 2V Battery:** Determine total battery Ah. Example: 18-NXS770. The 770 describes the amp-hour rating.

**(+) cable/(-) cable:** Select the cable the Wi-iQ®4 device has been installed on. In most cases, (-) cable should be selected.

**Equal Period (hours):** Enter 186. This is the time in hours to request an equalization charge (only available with Wi-iQ®4 device firmware v4.0 and higher). If equal time is set to 0 hours, this disables the feature and critical faults are not recorded on reports. This feature is not programmable for Nexsys® battery profiles.

**Balance:** Check this box for all batteries.

**Water Level Probe:** Check this box for all batteries with an electrolyte probe installed.

# COMMUNICATION

## Communication (cont.)

**Mode:** Leave as default – CYCLES, unless line-item notes on Order Acknowledgement requires an alternative mode setting by the customer or sales representative.

**NOTE:** Click on the “WRITE IDCARD” button before changing the mode. If the mode is changed first, then restart configuration from the Truck iQ™ Smart Battery Dashboard section.

- Xinx™ Systems require the Mode to be EVENT.

**Dates:** Enter the date from the battery date code for the “Date Manufac. Bat.” Field. Enter the date the battery is placed in service for the “Date Inst. serv.” field. Leave all other date fields blank.

**Owner:** Leave as default – EnerSys®.

**Battery Group:** Enter truck type – Sit Down, Reach, etc., or as designated by customer.

- For Xinx™ software, refer to the Xinx™ software set-up worksheet.

**Charger Group:** Charger Model or Charger Max Output

Summertime Setting: OFF/Europe/Australia.

Once you have entered all of the required information, click on the “WRITE IDCARD” button. Select the “Write” button and confirm settings are written.

Click on the “CYCLES” tab. Find the button called “Reset Cycles” and click on it, select “Continue” when the warning message appears. This will erase any memory in the device. Installation is now complete. It is important to reset the data on a new installation for proper averaging calculations.

- “Reset Events” for Xinx™ software or any setup requiring EVENT Mode.

**Figure 11:** CycleTAB

### Xinx™ System Setup

Change mode to EVENT

- The Battery Group must be set for the correct Pool Name following the note on the order and/or the Xinx™ BOM profile; e.g. Dock Stockers, Pallet Jack, etc. If you use all capital letters for one pool, make sure all the pools are named using all caps. This will be provided via a custom note on the order and/or the Xinx™ BOM profile. Any typo may result in the Xinx™ system failing to recognize the battery.

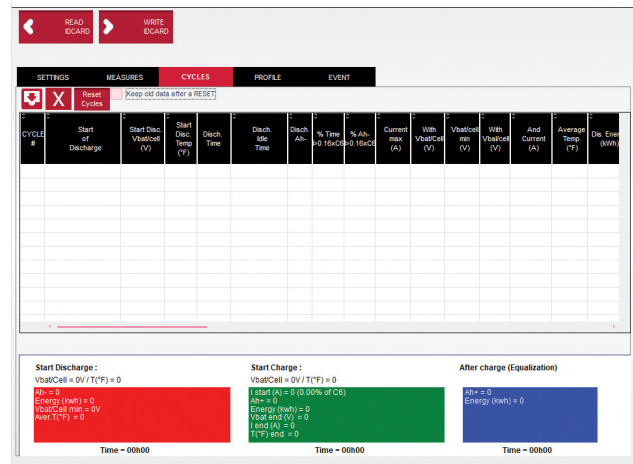

**Figure 11**

- Use the “MEASURES” tab to verify setup.
- Select the “MEASURES” button to read Wi-iQ®4 device real-time data.
  - Measure the voltage from the positive terminal of the battery to the VBAL/CEL gray wire with a calibrated voltmeter. Divide the reading by the number of cells between the positive terminal and the balance wire. Compare this value to the “VBAL/CEL” reading and confirm it is within a tolerance of (+/- .02 VDC). Deviation from this value indicates the wrong number of cells was input into the “Cells Bal” field, or the balance wire is in the wrong location.
  - Measure the voltage between the positive and negative battery posts with a calibrated voltmeter. Divide the number of cells in the battery and confirm this value is within a tolerance of (+/- .03 VDC) of the value in “VBAL/CEL”. Deviation from this value may indicate a bad electrical connection. Clean and grease the battery post and terminal lug.
  - Measure the temperature near the Temperature Probe on the battery. Verify the value in the “Temp” field is near the as read value. Large deviations indicate a bad thermal sensor.
  - If possible, operate the equipment or charge the battery. Measure the current with a calibrated clamp-on ammeter and confirm the value is within (+/- 2%) tolerance of the value in “CURRENT”. Deviation from this value indicates a bad Hall effect sensor.
    - Also verify the current is in the proper direction, (-) for discharger and (+) for charge. Deviation from this indicates the Hall effect sensor was installed backward.

## Communication (cont.)

- Verify the electrolyte indicates properly. If the probe is covered and the indication in “Measures” is not green, verify the balance wire is on the negative post of the same cell the electrolyte probe is installed.

Figure 12: Live Readings on Wi-iQ® Report.

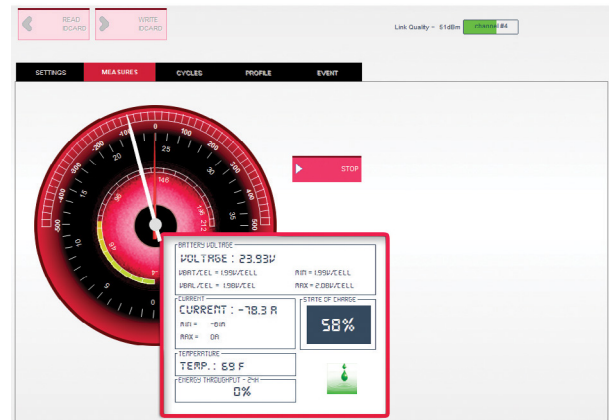

Figure 12

### Configuring Wi-iQ®4 device within the E Connect™ mobile app

A mobile app called E Connect™ was developed for iOS® and Android® operating systems (will not work on Windows platforms), available for download for free from the App Store and Play Store. Access is protected by login/password. Different access levels will be granted through different access codes.

The E Connect™ mobile app allows mainly:

- Scanning and then associating the Wi-iQ®4 device to a customer site (list of devices will be automatically recorded on a remote server).
- Setting the Wi-iQ®4 device battery parameters (such as technology and capacity).
- A quick review of historical parameters such as SoC, voltage, and temperature.
- Downloading the Wi-iQ®4 device history data (data downloaded are automatically transferred to a remote server – there is no data stored on the Smartphone).

### NOTES:

- When launching the mobile app, Bluetooth® is automatically activated.
- If the Smartphone is not connected to Internet during scan and data download, the transfer to the remote server will be done as soon as the Internet connection is restored.

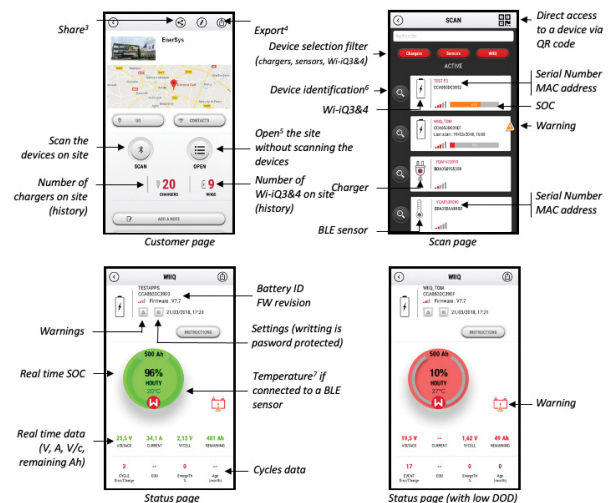

Figure 13

The main screens of the E Connect™ mobile app with the main parameters are shown below.

Figure 13: E Connect™ Mobile App Screens

Refer to “Configuring Wi-iQ®4 Device within Wi-iQ® Report” to configure the battery parameters in the Wi-iQ®4 device settings page of the app. The info required is the same (ie battery s/n, customer info, battery technology, battery capacity, number of cells, etc).

# COMMUNICATION

## Communication (cont.)

Figure 14: E Connect™ Mobile App Available Menu Options

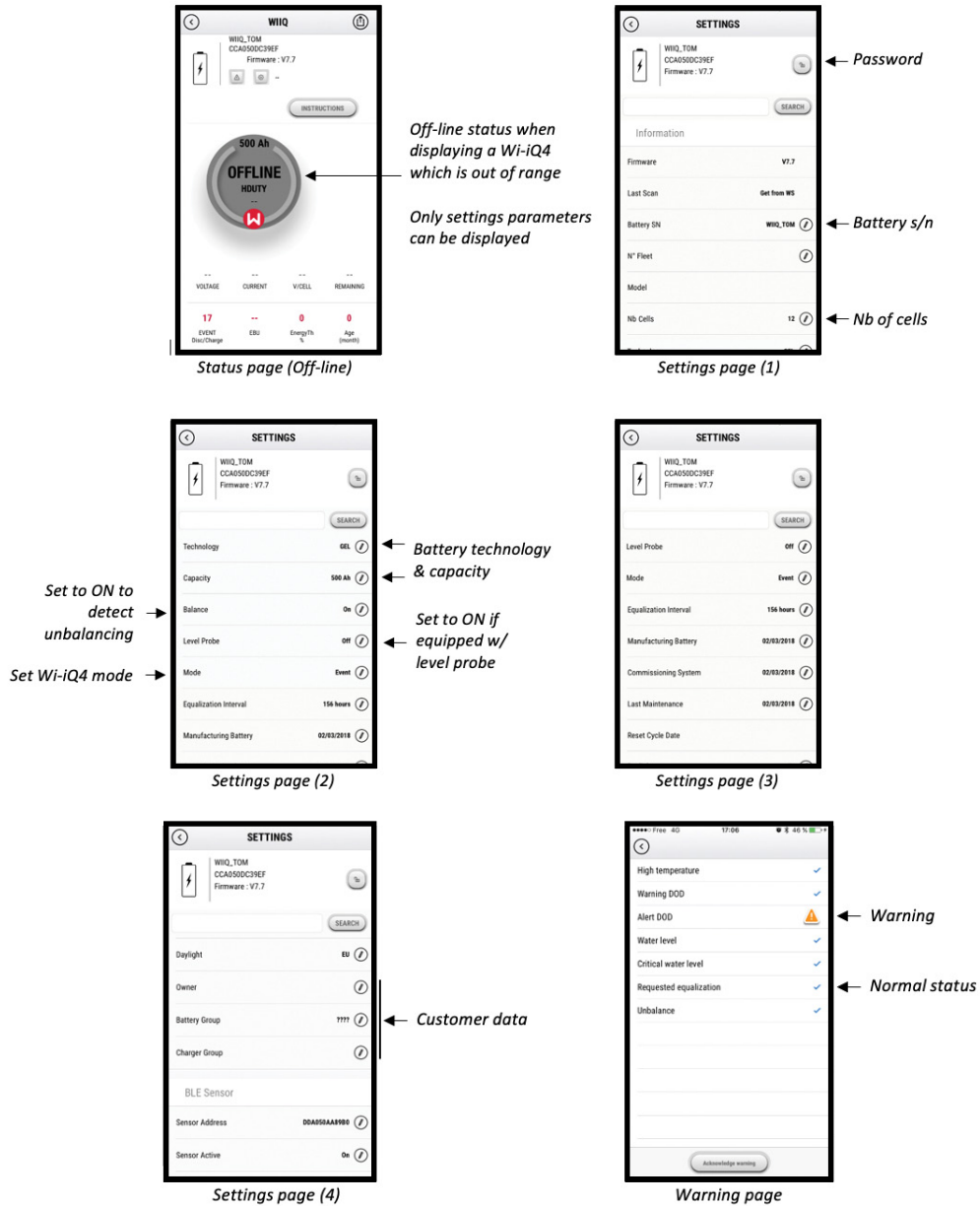

Multiple graphs are available (SOC, temperature, Ah...) with various period filters (day, week, year).

Figure 14

## Communication (cont.)

### Truck iQ™ smart battery dashboard

- The Truck iQ™ smart battery dashboard is one of the latest “iQ” devices from EnerSys®.
- The device consists of a display powered by the battery via the truck cables. It reads in real-time and wirelessly data from the Wi-iQ®4 device, displaying alerts, alarms, SoC, and other useful parameters to optimize the operation of the battery.
- Pairing Truck iQ™ dashboard with Wi-iQ®4 device
- The Truck iQ™ dashboard can be paired with the Wi-iQ®4 device either manually or automatically.
  - Manual Procedure



**Figure 15:** Wi-iQ®4 Device Communicates with Truck iQ™ Smart Battery Dashboard to Display Critical Battery Information

**Figure 16:** Wi-iQ®4 Device and Truck iQ™ Dashboard Pairing Instructions

### CAN (Controlled Area Network) Communication

- EnerSys® allows integration via CAN-supported protocols interfacing with the following:
  - Trucks using OEM’s proprietary CAN protocol implemented in the Wi-iQ®4 device firmware.
  - AGVs (Automated Guided Vehicle) using EnerSys proprietary CAN protocol (CANopen Cia 418 or J1939).
- List of parameters communicated via CAN to trucks as specified by OEM’s proprietary protocol, but not limited to:
  - USOC (Usable State of Charge)
  - DC Bus Voltage
  - DC Bus Current
  - System temperature (battery temperature)
  - Lift Lock-out trigger
  - Limited Operation trigger
- For more details, please refer to the CAN Interface Specification provided with the truck’s user manual for each specific OEM.
- Parameter communicated via CAN to AGV as specified by EnerSys® proprietary CAN protocol, but not limited to:
  - USOC (Usable State of Charge)
  - DC Bus Voltage
  - DC Bus Current
  - System temperature (battery temperature)
- **For more details, please refer to EnerSys® Global: CANopen and CAN J1939 specification for battery controller document ENER-CO-002 and document EnerSys\_J1939.**

Setting -> I/O -> Pairing -> Disable Auto pairing.

Select the appropriate Wi-iQ®4 device by clicking on the BLE (Bluetooth®) icon.

**NOTE:** The Wi-iQ®4 device is normally equal to the battery name.



**Figure 16**

## Service and Troubleshooting

### Displayed Error Messages

**Figure 17:** Wi-iQ<sup>®</sup>4 Device LEDs.

Check the LED indicators on the device. Fast blinking every five seconds of all LEDs indicates successful setup and normal operation. Refer to the table below for troubleshooting other indicators:

LED Indicator	LCD Display	Meaning
Short blink (0.5 s) every 5 seconds		Installation OK
Flashing Blue		Balance installed or programmed incorrectly
	No level probe	Level probe selected but not working
	No current sensor	Current sensor not working
Flashing Red	No temp sensor	Temp sensor broken, replace Wi-iQ <sup>®</sup> 4

### Connect to the device with the E Connect™ mobile app

- If it won't connect, verify no other devices are connected, such as another app or Truck iQ™ dashboard. It can only connect to one device at a time.
- Try to connect with a computer and Wi-iQ<sup>®</sup> Report.
- If it doesn't connect to either device, move the Wi-iQ<sup>®</sup>4 device to another area, preferably outdoors.
  - If it connects to another location, the problem is radio-magnetic interference.
  - If it does not connect, replace the Wi-iQ<sup>®</sup>4 device.

Perform the following quality checks to confirm proper installation. Compare values displayed on the LCD with variables measured from the battery (i.e., voltage, temperature, etc.).

- Select the "MEASURES" button to read Wi-iQ<sup>®</sup>4 device real-time data.
  - Measure the voltage from the positive terminal of the battery to the VBAL/CEL gray wire with a calibrated voltmeter. Divide the reading by the number of cells between the positive terminal and the balance wire. Compare this value to the "VBAL/CEL" reading and confirm is within a tolerance of +/- .02 VDC. Deviation from this value indicates the wrong number of cells



**Figure 17**

was input into the "Cells Bal" field, or the balance wire is in the wrong location.

- Measure the voltage between the positive and negative battery posts with a calibrated voltmeter. Divide the number of cells in the battery and confirm this value is within a tolerance of +/- .03 VDC of the value in "VBAT/CEL". Deviation from this value may indicate a bad electrical connection. Clean and grease the battery post and terminal lug.
- Measure the temperature near the Temperature Probe on the battery. Verify the value in the "Temp" field is near the as-read value. Large deviations indicate a bad thermal sensor.
- If possible, operate the equipment or charge the battery. Measure the current with a calibrated clamp-on ammeter and confirm the value is within +/- 2% tolerance of the value in "CURRENT". Deviation from this value indicates a bad Hall effect sensor.
  - Also verify the current is in the proper direction, (-) for discharger and (+) for charge. Deviation from this indicates the Hall effect sensor was installed backward.
- Verify the electrolyte indicates properly. If the probe is covered and the indication in "Measures" is not green, verify the balance wire is on the negative post of the same cell where the electrolyte probe is installed.
  - If installed correctly, inspect the probe for corrosion. Replace probe if damaged.

**For service, contact your EnerSys<sup>®</sup> sales representative or visit [www.enersys.com](http://www.enersys.com).**



[www.enersys.com](http://www.enersys.com)

© 2025 EnerSys. All rights reserved. Unauthorised distribution prohibited. Trademarks and logos are the property of EnerSys® and its affiliates except UL, CE, UKCA, IEC, Android, iOS, Bluetooth, and Zigbee, which are not the property of EnerSys®. Subject to revisions without prior notice. E.&O.E.

EMEA-EN-OM-ENS-WIQ-0425

***EnerSys***®

*Power/Full Solutions*