



| an EnerSys® company

Cordex® CXPS-W-FA, CXPS-W 2,000A Power System

User Guide ID: 9400010-J0

Effective: 03/2025



Read this document carefully.

Learn how to protect your equipment from damage and fully understand its functions.

The material contained in this document is for information only and is subject to change without notice. Alpha® reserves the right to make changes in the product design without reservation and without notification to its users.

Contents

1. Safety.....	4
1.1 Safety symbols.....	4
1.2 General warnings and cautions	4
1.3 General safety requirements for AC cord connected shelf installation and servicing.....	5
1.4 Mechanical safety.....	5
1.5 Electrical safety.....	6
1.6 Installation and safety precautions	6
1.7 Lifting	7
2. Introduction.....	8
2.1 Document scope.....	8
2.2 Product overview.....	8
2.3 Cordex® CXPS-W-FA Front Access Power System	9
3. Specifications	10
3.1 Cordex® CXPS-W-FA, CXPS-W 2,000A Power System	10
4. Features	12
4.1 System overview	12
4.2 Cordex® HP System Controller	21
4.3 External peripherals	22
4.4 Cordex® HP 4.0/4.6 kW Rectifier Shelves	24
4.5 Cordex® HP 2.4/3.0 kW Rectifier Shelves	26
4.6 Integrated battery trays	28
4.7 Remote return bar kit.....	29
5. Inspection	31
5.1 Packaging materials.....	31
5.2 Returns for service	31
5.3 Check for damage	31
5.4 General receipt of shipment	31
6. Installation.....	32
6.1 Safety precautions	32

6.2	Tools required.....	32
6.3	Installation of external batteries	32
6.4	Battery maintenance report	34
6.5	Power system assembly and mounting	35
7.	Wiring.....	37
7.1	Installation notes	37
7.2	Grounding	38
7.3	Front access system: AC supply wiring	40
7.4	AC supply for the rectifier modules	45
7.5	Standard system: AC wiring for the Cordex® HP 2.4/3.0 kW Rectifier Shelf	47
7.6	DC wiring.....	49
7.7	Dual voltage conversion.....	50
7.8	High capacity breaker alarm and shunt wiring.....	51
7.9	Signal wiring	52
8.	System startup	54
8.1	Factory ranges and default values	55
9.	Maintenance.....	56
10.	Troubleshooting	57
10.1	Cordex® HP Rectifier Module LEDs	57
10.2	Cordex® HP System Controller LEDs	57
10.3	Cordex® HP L-ADIO Low Voltage Smart Peripheral LEDs.....	58







1. Safety

Save these instructions

This document contains important safety instructions that must be followed during the installation, servicing, and maintenance of the product. Keep it in a safe place. Review the drawings and illustrations contained in this document before proceeding. If there are any questions regarding the safe installation or operation of this product, contact Alpha Technologies Ltd. or the nearest Alpha® power system representative.

1.1 Safety symbols

To reduce the risk of injury or death, and to ensure the continued safe operation of this product, the following symbols have been placed throughout this document. Where these symbols appear, use extra care and attention.

Symbol	Type	Description
	WARNING	Risk of serious injury or death Equipment in operation poses a potential electrical hazard which could result in serious injury or death to personnel. This hazard may continue even when power is disconnected.
	CAUTION	Cautions indicate the potential for injury to personnel.
	CAUTION	Risk of burns A device in operation can reach temperature levels which could cause burns.
	ATTENTION	The use of attention indicates specific regulatory or code requirements that may affect the placement of equipment or installation procedures. Follow the prescribed procedures to avoid equipment damage or service interruption.
	GROUNDING	This symbol indicates the location or terminal intended for the connection to protective earth. An enclosure that is not properly connected to protective earth presents an electrical hazard. Only a licensed electrician can connect AC power and protective earth to the enclosure.
	NOTICE	A notice provides additional information to help complete a specific task or procedure or general information about the product.

1.2 General warnings and cautions

You must read and understand the following warnings before installing the system and its components. Failure to do so could result in personal injury or death.

- Read and follow all instructions included in this document.
- Only trained personnel are qualified to install or replace this equipment and its components.
- Use proper lifting techniques whenever handling equipment, parts, or batteries.

**WARNING**

This system is designed to be installed in a restricted access location that is inaccessible to the general public.

**AVERTISSEMENT**

Ce système est conçu pour être installé dans un endroit à accès restreint inaccessible au grand public.

**WARNING**

This equipment is not suitable for use in locations where children are likely to be present.

**AVERTISSEMENT**

Cet équipement ne convient pas pour une utilisation dans des lieux où des enfants sont susceptibles d'être présents.

1.3 General safety requirements for AC cord connected shelf installation and servicing

**WARNING**

The plug on the AC cord connected shelf is to be used as a disconnect device therefore the socket-outlet shall be **ACCESSIBLE**. A licensed electrician must verify there is a protective earthing connection within the socket-outlet.

**AVERTISSEMENT**

La fiche de l'étagère connectée au cordon secteur doit être utilisée comme dispositif de déconnexion, la prise de courant doit donc être **ACCESSIBLE**. Un électricien agréé doit vérifier qu'il y a une connexion de mise à la terre de protection dans la prise de courant.

**CAUTION**

When connected to the **MAINS**, the AC cord shall be secured in a method that mitigates mechanical strain throughout the cord or cord terminations.

**PRUDENCE**

Lorsqu'il est connecté à la source d'alimentation principale, le cordon d'alimentation secteur doit être fixé de manière à atténuer les contraintes mécaniques à travers le cordon ou les terminaisons du cordon.

1.4 Mechanical safety

- Keep hands and tools clear of fans. Fans are thermostatically controlled and switch on automatically.
- Power supplies can reach extreme temperatures under load.
- Use caution around sheet metal components and sharp edges.

1.5 Electrical safety



WARNING

Hazardous voltages are present at the input of power systems. The DC output from rectifier modules, converter modules, and the battery system have a high short-circuit current capacity that can cause severe burns and electrical arcing.

Before working with any live battery or power system, follow these precautions:

- Remove all metallic jewelry, such as watches, rings, metal rimmed glasses, or necklaces.
- Wear safety glasses with side shields at all times during the installation.
- Use Occupational Safety and Health Administration (OSHA®) approved insulated hand tools. Do not rest tools on top of batteries.



WARNING

Lethal voltages are present in the power system. Always assume that an electrical connection or conductor is energized. Check the circuit with a voltmeter with respect to the grounded portion of the enclosure (both AC and DC) before performing any installation or removal procedure.



WARNING

High leakage current

Earth connection is essential before connecting the power supply.



CAUTION

Internal DC breakers can be hot surfaces. Use a bullet socket removal tool for removal of circuit breakers.

- Do not work alone under hazardous conditions.
- A licensed electrician is required to install permanently wired equipment. Hazardous voltages are present at the input of power systems. Ensure that the utility power is disconnected and locked out before performing any installation or removal procedure.
- Ensure that no liquids or wet clothes come into contact with internal components.
- Hazardous electrically live parts inside this unit are energized from the batteries even when the AC input power is disconnected.
- Always assume electrical connections or conductors are live. Turn off all circuit breakers and double-check with a voltmeter before performing installation or maintenance.
- Place a warning label on the utility panel to warn emergency personnel that a reserve battery source is present which will power the loads in a power outage condition or if the AC disconnect breaker is turned off.
- At high ambient temperature conditions, the internal temperature can be hot so use caution when touching the equipment.

1.6 Installation and safety precautions

- Only qualified personnel should install and connect the power components in the power system.
- Make sure to connect the protective earthing (master grounding) terminal in the AC loadcenter of the equipment to the earth point in the building installation or the site reference ground.
- Only install the power system using the mounting hardware provided by Alpha Technologies Ltd.

1.7 Lifting



CAUTION

Follow all local safety practices and guidelines while lifting the power system. All personnel involved with lifting and positioning the power system must wear head and eye protection, and gloves. Only properly trained and certified personnel should operate the crane. Only properly trained and certified personnel should operate the forklift.

Before lifting the power system into place:

- Ensure the modules are not installed.
- The distribution panel door is firmly affixed.

2. Introduction

2.1 Document scope

This document covers the features, options, installation, and startup of the Cordex® CXPS-W-FA, CXPS-W 2,000A power system. Images contained in this document are for illustrative purposes only and may not exactly match your installation.

2.2 Product overview

The Cordex® CXPS-W-FA, CXPS-W 2,000A power system is a compact multi-capacity power system designed for cell site, small central office, and cable head end applications. The distribution options are extremely flexible; providing TPL fuse distribution, high capacity circuit breaker distribution, TPS/TLS fuse distribution, and plug-in circuit breakers. Shunts are available for both tier and branch current monitoring.

The power system may also be configured with either low voltage load disconnect (LVLD) or low voltage battery disconnect (LVBD) functionality.

The power system utilizes standard Cordex® power system (CXPS) components and is a perfect solution for space constrained applications due to the compact front access design.

Power systems are equipped with the Cordex® HP system controller for single point control, advanced battery diagnostics, data logging, local and remote monitoring, including SNMP alarming.

Power systems are available with front access or standard connections.

The power system is suitable for installation in:

- Network telecommunication facilities
- Locations where the NEC® applies.

Wireless applications

- High density Cordex® HP 2.4/3.0kW rectifier modules, provide capability to add multiple battery trays below the power system.
- Field convertible tiers provide flexibility in distribution for dual voltage applications.

Wireline applications

- The power system can be installed close to the equipment at the end of a line, using high capacity circuits (TPL fuses/GJ style circuit breakers) to feed remote distribution panels mounted in equipment bays.
- It can be equipped with AM style circuit breakers or TPS/TLS fuses that directly feed the network equipment in a distributed architecture.
- Larger rectifier modules (Cordex® HP 4.0/4.6kW rectifier modules) provide the flexibility to configure economical higher ampacity systems.



Figure 1: Cordex® CXPS-W-FA 2,000A power system

2.3 Cordex® CXPS-W-FA Front Access Power System

The new Cordex® CXPS-W-FA front access power system is an evolution of the popular Cordex® CXPS-W power system. All AC terminations have been moved from the rear (standard system) to the front of the bay with top entry and side channel to a DIN rail AC termination pane. The new power system also improves access to the return bar. f

The system controller has also been relocated to provide easier access and visibility of the display panel. For more information, see the drawings at the end of this document or contact Alpha Technologies Ltd. or the nearest Alpha® power system representative.

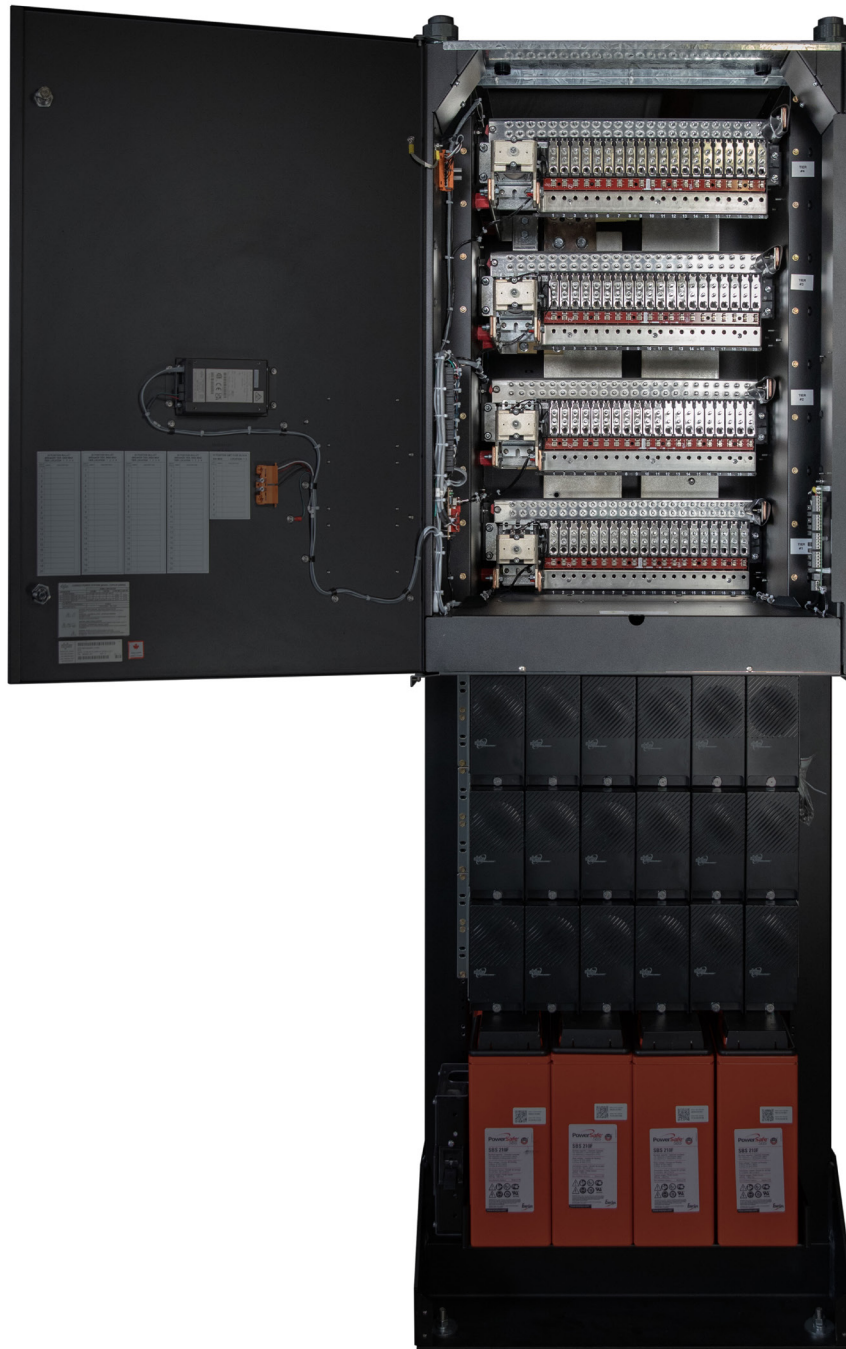

Figure 2: Cordex® CXPS-W-FA 2,000A front access power system

3. Specifications

3.1 Cordex® CXPS-W-FA, CXPS-W 2,000A Power System

Table A: Cordex® CXPS-W-FA, CXPS-W 2,000A power system specifications

Electrical	
Primary output voltage	-48V
Secondary output voltage (optional)	+24V
Cordex® HP 4.0/4.6kW rectifier shelf AC input	6 × 30A, 1-phase, 208 to 277VAC
	2 × 50A, 3-phase, 208VAC (without neutral)
	2 × 30A, 3-phase, 277/480VAC (with neutral)
Cordex® HP 2.4/3.0kW rectifier shelf AC input	2 × 40A and 1 × 20A 1-phase, 208 to 277VAC
Distribution	
System ampacity rating (continuous)	1-tier system bus capacity: 600A
	2-tier system bus capacity: 1,200A
	3-tier system bus capacity: 1,200A (standard system) or 1,800A (standard or front access system)
	4-tier system bus capacity: 1,200A (standard system) or 2,000A (standard or front access system)
Fuses	
GMT fuse	30A, 10 positions (15A maximum fuse)
High capacity TPL fuse	Up to 8 positions in a 4-tier distribution, (800A maximum fuse)
Low capacity TPL fuse	Up to 16 positions in a 4-tier distribution, (400A maximum fuse)
TLS/TPS plug-in bullet fuse	Up to 96 positions
Circuit breakers	
High capacity plug-in bullet circuit breaker	Up to 96 positions in a 4-tier distribution system
High capacity bolt-in circuit breaker	Up to 24 positions in a 4-tier distribution system
Output termination	
GMT fuse	14 to 22 AWG (0.34 to 2.5 mm ²)
High capacity TPL fuse	2 × 3/8 inch studs on 1 inch centers; up to 2 × 750 MCM (400 mm ²) cables
Low capacity TPL fuse	1 × 3/8 inch studs on 1 inch centers; 1 × 750 MCM (400 mm ²) cable
High capacity bolt-in circuit breaker	1 × 3/8 inch studs on 1 inch centers; 1 × 750 MCM (400 mm ²) cable
TLS/TPS/plug-in circuit breaker	1-pole: 1/4 inch studs on 5/8 inch centers
	2-pole and 3-pole: 3/8 inch studs on 1 inch centers
Internal ground bar	1/4 inch holes on 5/8 inch centers
External ground bar	Optional
Battery	5 × 3/8 inch holes on 1 inch centers per polarity

System level alarms and controls	
Alarm and control parameters are user-programmable through built-in system controller.	
System controller	Cordex® CXC HP system controller; touchscreen LCD panel
LEDs	Status and alarms
Alarm connections	14 to 22 AWG (0.34 to 2.5 mm ²)
Mechanical	
Mounting	Standard center mount 23-inch relay rack
Dimensions H x W x D	Front access system: 84 x 28 x 24 in. (2133 x 711 x 610 mm)
	Standard system: 84 x 26 x 22 in. (2133 x 660 x 560 mm)
Net weight	System: 650 lb (295 kg) approximately
Environmental	
Operating temperature	32 to 104°F (0 to 40°C)
Storage temperature	-40 to 185°F (-40 to 85°C)
Relative humidity	0 to 95% non-condensing
Elevation	Up to 9,842 ft (3,000 m)
Regulatory compliance	
Safety	CAN/CSA C22.2 No. 62368-1 3 rd Edition
	UL 62368-1 3 rd Edition
Network Equipment-Building Systems (NEBS)	NEBS Level 3 Certified



NOTICE

Refer to the rectifier and system controller documentation for more information regarding modules and shelves included in your power system.

4. Features

4.1 System overview

4.1.1 Seismic racks

The power system can be installed in a variety of Alpha® provided, 23-inch seismic racks. The power system rack has been Z4 rated and NEBS Level 3 certified for up to 2,500 pounds. For more ordering information, contact Alpha Technologies Ltd. or the nearest Alpha® power system representative.

Certain list options on the one tier and the two tier systems can be purchased with system mounting brackets so that the systems can be installed into existing customer provided racks.

Size	Description (standard system only)
7RU	One tier Two Cordex® HP 2.4/3.0 kW rectifier shelves
9RU	One tier One Cordex® HP 4.0/4.6 kW rectifier shelf
11RU	Two tiers Two Cordex® HP 2.4/3.0 kW rectifier shelves
13RU	Two tiers One Cordex® HP 4.0/4.6 kW rectifier shelf or Four Cordex® HP 2.4/3.0 kW rectifier shelves
17RU	Two tiers Two Cordex® HP 4.0/4.6 kW rectifier shelves

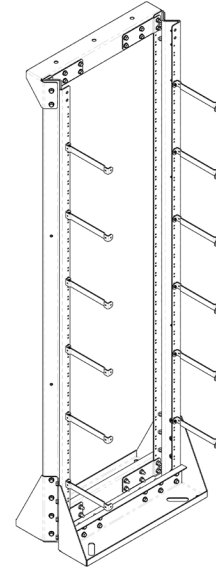

4.1.2 Distribution cabinets

One tier

- Maximum of one distribution tier
- Rated for 600 A (maximum)
- **Front access system:** 7RU
Standard system: 5RU
- Five battery landing positions (10 cables back to back) (return bar has one extra position for the site ground)
- **Maximum lug tongue width:** 1.63 inch

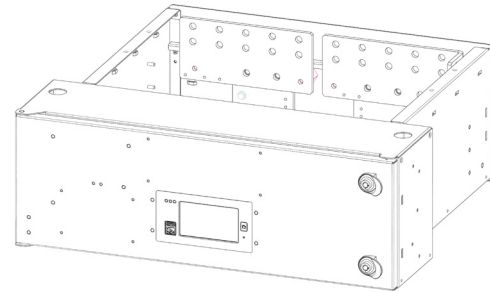

Two tiers

- Maximum of two distribution tiers
- Rated for 1,200 A (maximum)
- Option for a 1,200 A LVBD
- **Front access system:** 11RU
Standard system: 9RU
- Five battery landing positions (10 cables back to back) (return bar has one extra position for the site ground)
- **Maximum lug tongue width:** 1.63 inch

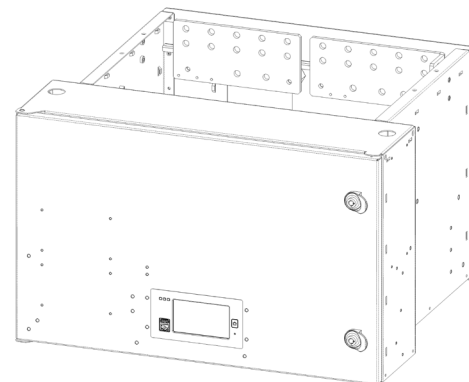

Three tiers

- Maximum of three distribution tiers
- **Front access system:** Rated for 1,800A (maximum)
Standard system: Rated for 1,200A (maximum)
- **Front access system:** Option for a 2,000A LVBD
Standard system: Option for a 1,200A LVBD
- **Front access system:** 16RU
Standard system: 14RU
- Five battery landing positions (10 cables back to back) (return bar has one extra position for the site ground)
- **Maximum lug tongue width:** 1.63 inch

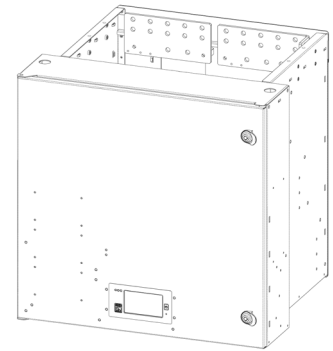

Four tiers

- Maximum of four distribution tiers
- **Front access system:** Rated for 2,000A (maximum)
Standard system: Rated for 1,200A (maximum)
- **Front access system:** Option for a 2,000A LVBD
Standard system: Option for a 1,200A LVBD
- **Front access system:** 22RU
Standard system: 20RU
- Five battery landing positions (10 cables back to back) (return bar has one extra position for the site ground)
- **Maximum lug tongue width:** 1.63 inch

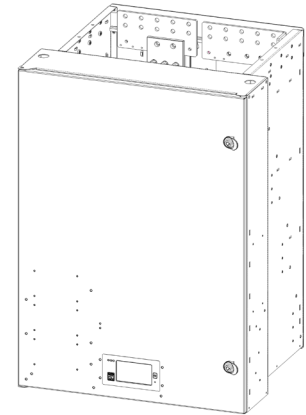

4.1.3 Low voltage battery disconnect option

The system controller monitors battery voltage. If AC power is lost, the batteries continue to provide DC power to the load and the DC-to-DC converter modules (if present). When the battery voltage reaches a predetermined (adjustable) level, the system controller will disconnect the batteries to protect them from full discharge.

The low voltage battery disconnect (LVBD) option includes a manual disconnect switch and terminal block for field wiring an external switch to disconnect the batteries manually from either in the distribution unit or remotely. The LVBD override switch provides users with the ability to inhibit or override LVBD contactor operations as a safeguard during system controller maintenance. A green LED illuminates when the LVBD is in normal operation mode (auto) and a yellow LED signals when the switch has been placed in the override position.

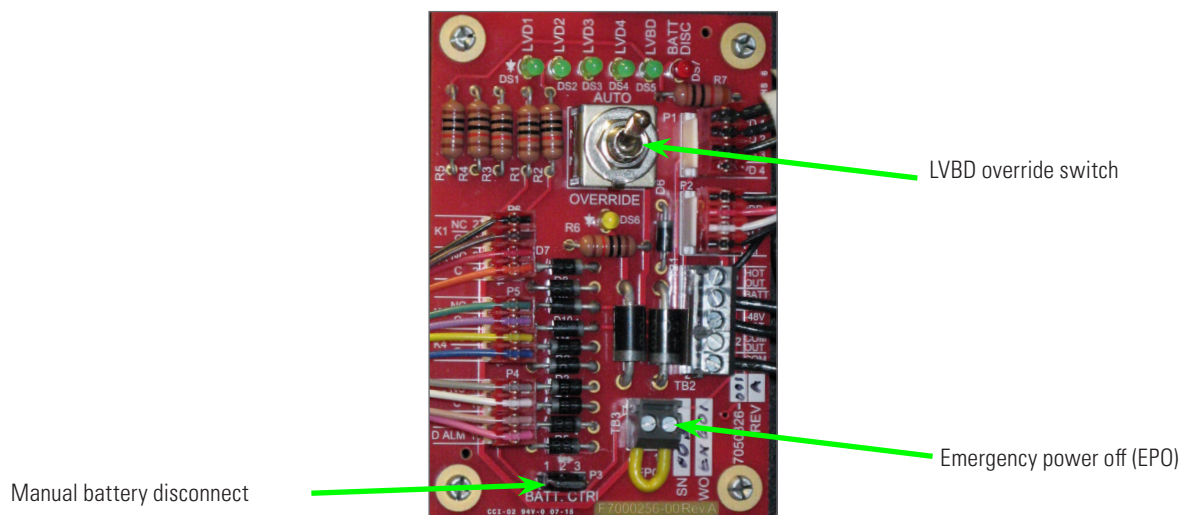

Figure 3: LVBD override and manual battery disconnect

4.1.4 24-position bullet tier

- Occupies one tier position and it can be installed in any location in the distribution cabinet
- 600A tier rating (monitored by 800A shunt)
- Each tier accepts 1-pole (125A), 2-pole (200A), 3-pole (300A) plug-in style circuit breakers
- 1-pole circuit breaker or fuse ($\frac{1}{4}$ inch studs on $\frac{5}{8}$ inch centers)
- 2-pole and 3-pole circuit breaker ($\frac{3}{8}$ inch studs on 1 inch centers), via adapters
- Option for tier with internal return
- **Maximum lug tongue width:** 0.60 inch (1.06 inch with adapters)



ATTENTION

Any 1-pole overcurrent protection device, rated at 125A, requires an empty space on either side.

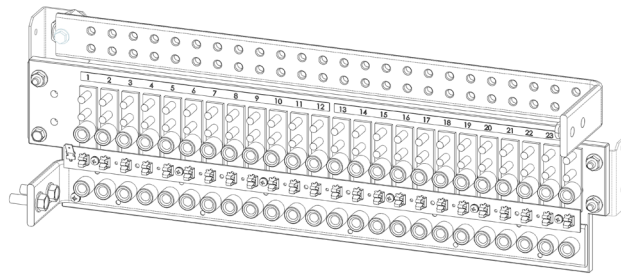

Figure 4: 24-position bullet tier

4.1.5 24-position staged bullet tier

Tier can be configured as 12 positions on primary bus and 12 positions on secondary bus, 16 positions on primary bus and eight positions on secondary bus, or 20 positions on primary bus and four positions on secondary bus **or** all 24 positions on primary bus.

- Occupies one tier position and it can be installed in any location in the distribution cabinet
- 600A tier rating (monitored by 800A shunt)
- The secondary to primary (or vice versa) can be converted in the field if required
- Each tier accepts 1-pole (125A), 2-pole (200A), 3-pole (300A) plug-in style circuit breakers
- 1-pole circuit breaker or fuse ($\frac{1}{4}$ inch studs on $\frac{5}{8}$ inch centers)
- 2-pole and 3-pole circuit breaker ($\frac{3}{8}$ inch studs on 1 inch centers), via adapters
- Option for tier with internal return
- **Maximum lug tongue width:** 0.60 inch (1.06 inch with adapters)



ATTENTION

Any 1-pole overcurrent protection device, rated at 125A, requires an empty space on either side.

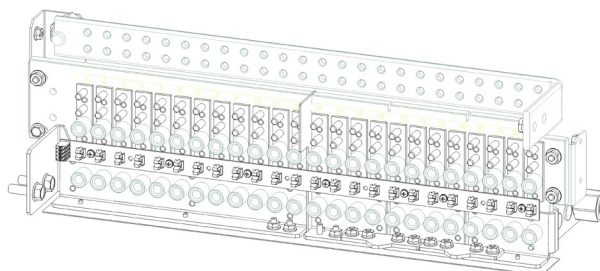

Figure 5: 24-position staged bullet tier

4.1.6 20-position bullet tier with LVLD

- Occupies one tier position and it can be installed in any location in the distribution cabinet
- 600A tier rating (monitored by 800A shunt)
- Load shedding via 600A contactor
- Each tier accepts 1-pole (125A), 2-pole (200A), 3-pole (300A) plug-in style circuit breakers
- 1-pole breaker or fuse ($\frac{1}{4}$ inch studs on $\frac{5}{8}$ inch centers)
- 2-pole and 3-pole breaker ($\frac{3}{8}$ inch studs on 1 inch centers), via adapters
- Option for tier with internal return
- **Maximum lug tongue width:** 0.60 inch (1.06 inch with adapters)



ATTENTION

Any 1-pole overcurrent protection device, rated at 125A, requires an empty space on either side.

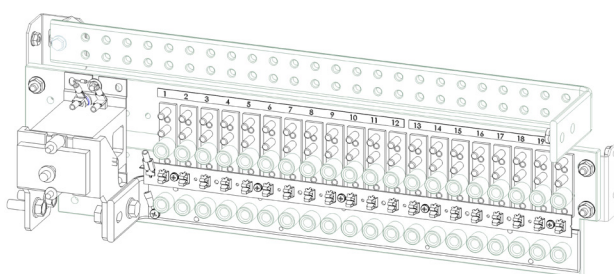

Figure 6: 20-position LVLD bullet tier

4.1.7 Low voltage load disconnects

The low voltage load disconnect (LVLD) option controls a high capacity contactor that disconnects the load during predetermined low voltage conditions. Similarly, the low voltage battery disconnect (LVBD) option disconnects battery at a preset disconnect voltage. The system loads and batteries are automatically reconnected once AC is restored and battery voltage has risen above a preset value.

4.1.8 2-position TPL tier

- Occupies one tier position and it can be installed in any location in the distribution cabinet
- 600A tier rating (monitored by 800A shunt)
- Each position accepts a 800A TPL fuse (maximum)
- Current on each TPL tier is monitored via an 800A shunt
- Three landings per fuse ($\frac{3}{8}$ inch nuts on 1 inch centers)
- Option for tier with internal return
- **Maximum lug tongue width:** 1.63 inch

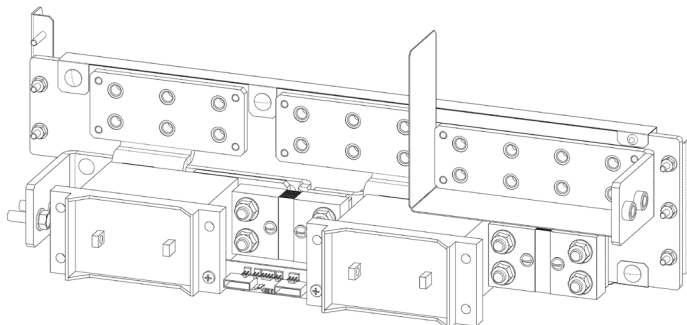
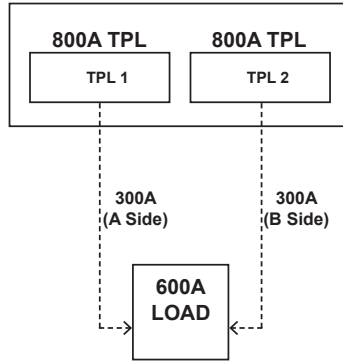

Figure 7: 2-position TPL tier

2-position TPL tier theory of operation



If TPL tier 1 or TPL tier 2 fuse positions operate and open, then the other TPL tier fuse position will carry the entire load current and not exceed the 80 percent rating of the fuse and the 600A rating of the tier.

4.1.9 4-position TPL tier

- Occupies one tier position and it can be installed in any location in the distribution cabinet
- 600A tier rating (monitored by 800 A shunt)
- Each position accepts a 400 A TPL fuse (maximum)
- Current on each TPL tier is monitored via a 400A shunt
- One landing per fuse ($\frac{3}{8}$ inch nuts on 1 inch centers)
- **Maximum lug tongue width:** 1.63 inch

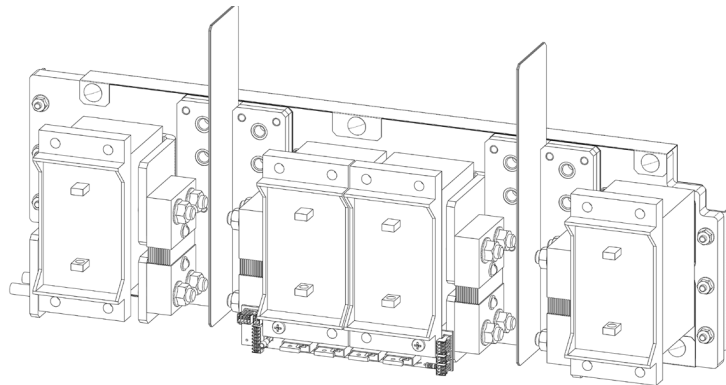
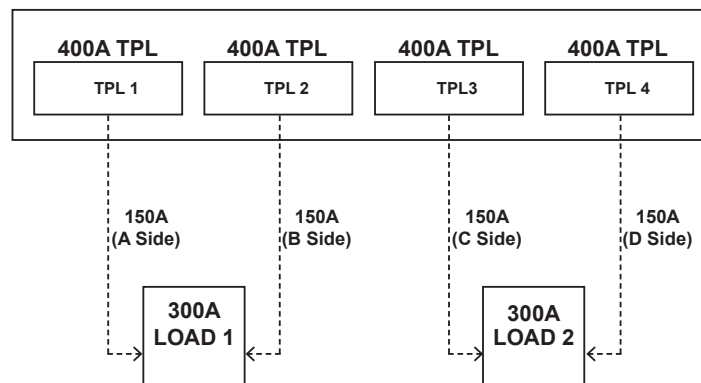

Figure 8: 4-position TPL tier

4-position TPL tier theory of operation



If TPL tier 1 or TPL tier 2/TPL tier 3 or TPL tier 4 fuse positions operate and open, then the other TPL tier fuse position will carry the entire load current and not exceed the 80 percent rating of the fuse and the 600A rating of the tier.

4.1.10 4-position TPL tier

- Occupies one tier position and it can only be installed in the top tier in the distribution cabinet
- 1,200A tier rating (monitored by 1,500A shunt)
- Each position accepts a 800A TPL fuse (maximum)
- Current on each TPL tier is monitored via an 800A shunt
- Two landings per fuse ($\frac{3}{8}$ inch nuts on 1 inch centers)
- **Maximum lug tongue width:** 1.75 inch

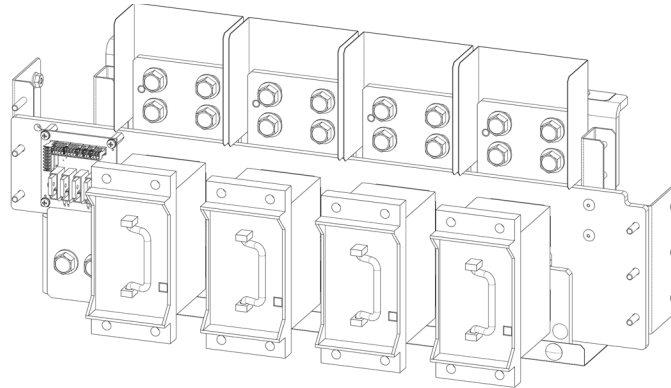

Figure 9: 4-position TPL tier

4.1.11 4-position high capacity circuit breaker tier

- Occupies one tier position and it can be installed in any location in the distribution cabinet
- 600A tier rating (monitored by 800A shunt)
- Can accept 1-pole to 4-pole (800A maximum) GJ style circuit breaker
- Breakers can be ordered with built-in shunts for individual load current monitoring
- One landing per position ($\frac{3}{8}$ inch nuts on 1 inch centers)
- Option for tier with internal return
- **Maximum lug tongue width:** 1.63 inch



NOTICE

Limitation: It cannot land more than two 750 MCM (400 mm²) cables on this tier option with an internal return.

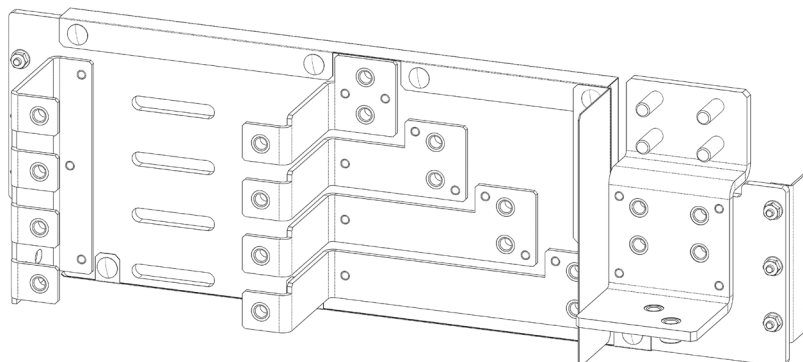

Figure 10: 4-position high capacity circuit breaker tier

4.1.12 12-position high capacity circuit breaker tier

- Occupies two tier positions and it can be installed only in specific locations in the distribution cabinet
 - Tiers 1 and 2, in a 2-tier distribution cabinet
 - Tiers 1 and 2, in a 3-tier distribution cabinet
 - Tiers 1 and 2 and tiers 3 and 4, in a 4-tier distribution cabinet
- 1,800A tier rating (monitored by 2,500A shunt)
- Can accept 1-pole to 4-pole (800A maximum) GJ style circuit breaker
- Breakers can be ordered with built in shunts for individual load current monitoring
- One landing per position ($\frac{3}{8}$ inch nuts on 1 inch centers)
- Option for tier with internal return
- **Maximum lug tongue width:** 1-pole: 1.06 inch, 2-pole: 1.06 inch, 3-pole: 1.63 inch, 4-pole: 1.63 inch

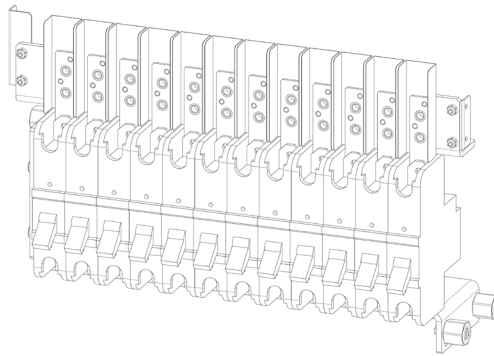

Figure 11: 12-position high capacity circuit breaker tier

4.1.13 12-position internal return bar

- It can only be installed in specific locations of the 2-tier, 3-tier, and 4-tier distribution cabinets
 - Maximum of one return bar in a 2-tier distribution cabinet
 - Maximum of one return bar in a 3-tier distribution cabinet
 - Maximum of two return bars in a 4-tier distribution cabinet
- 1,800A tier rating
- 12 lug landing positions ($\frac{3}{8}$ inch nuts on 1 inch centers)

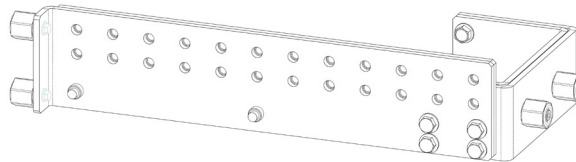

Figure 12: 12-position internal return (top of 4-tier and 2-tier)

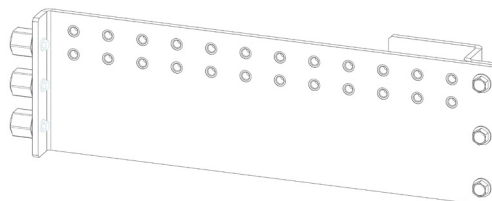

Figure 13: 12-position internal return (bottom of 3-tier and 4-tier)

4.1.14 10-position GMT fuse block

- It can be mounted on the side of the distribution cabinet
- 30A maximum rating
- Can accept 15A GMT fuses



NOTICE

Only install a 15A fuse if the adjacent positions are empty. Otherwise install a 10A fuse maximum per position.

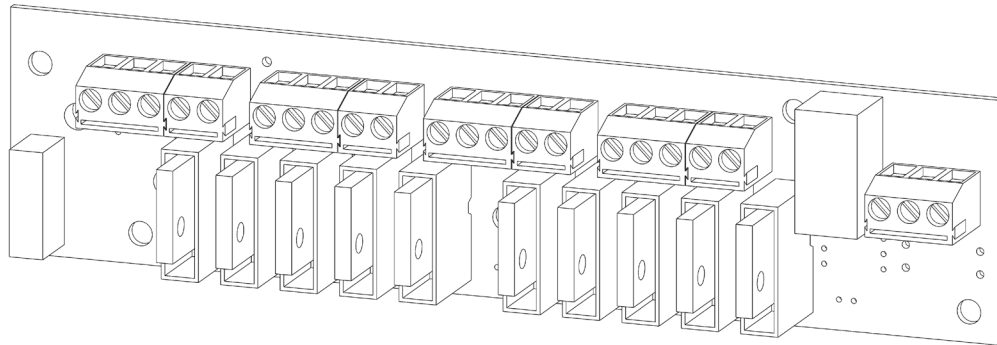

Figure 14: 10-position GMT fuse block

4.1.15 Top cover for distribution cabinet

- The top cover is a flexible shield that is made of insulated material that can be ordered and installed on top of the distribution cabinet.
- The covers helps prevent objects from falling into the distribution cabinet.
- Individual cutouts can be made on the cover to enable cable routing access.

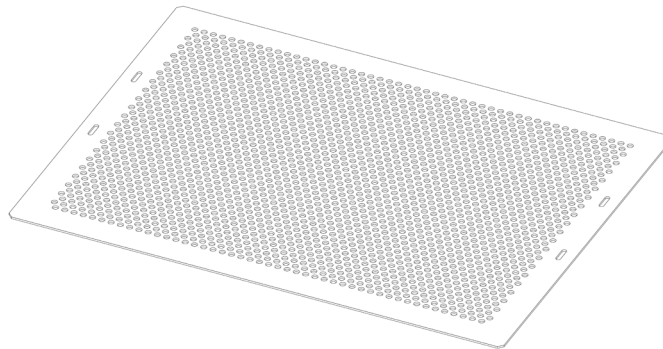

Figure 15: Distribution cabinet top cover

4.1.16 Cable lacing bar kit

- The cable lacing bar kit is a metallic bar that can be ordered and installed on the top of the cabinet (as shown in the following figure).
- This bar acts as a staging point for installers to lace cables that waterfall from the ladder rack prior to being terminated in the distribution cabinet. This helps if the ladder rack is installed several feet above the distribution section of the power system.
- Multiple lacing bar kits could be installed (based on the distribution cabinet ordered).
- Maximum of one lacing bar for a 1-tier or 2-tier distribution cabinet.
- Maximum of two lacing bars for a 3-tier distribution cabinet.
- Maximum of three lacing bars for a 4-tier distribution cabinet.

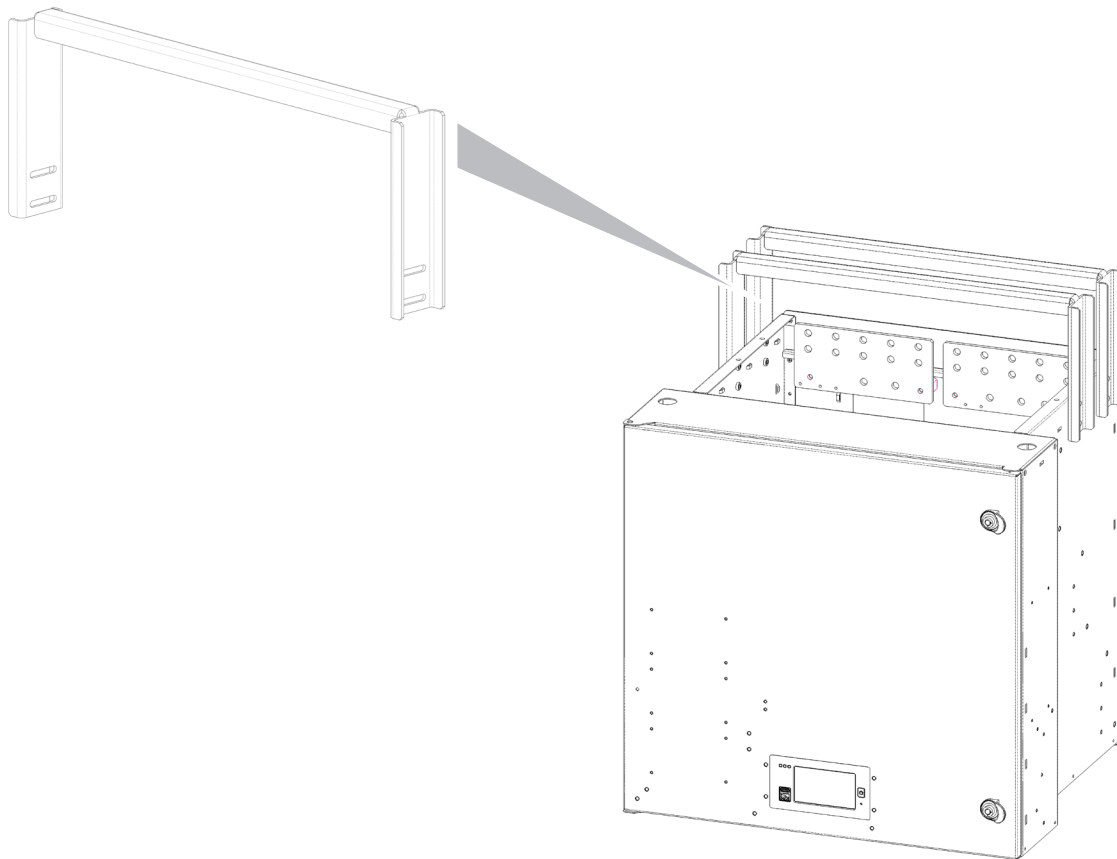

Figure 16: Cable lacing bar kit

4.2 Cordex® HP System Controller

The Cordex® CXC HP system controller provides centralized setup, control, and monitoring of power systems. This ranges from simple monitoring and threshold alarms for temperature, voltage and current, to advanced battery charging and diagnostic features.

The system controller supports dual Ethernet ports and a 4.3-inch touchscreen LCD panel to allow simultaneous network, and local laptop access to the system controller including both web and SNMP interfaces.

The system controller supports dual CAN ports to allow up to 256 power or ADIO peripherals to be controlled and monitored. The system controller uses external analog and digital I/O (ADIO) peripherals to monitor electrical signals (temperature, voltage, and temperature) and generate electrical signals through relays.

The most commonly used ADIO peripheral is the Cordex® HP L-ADIO low voltage smart peripheral for low voltage (<60VDC) systems which includes:

- Eight digital inputs
- Four voltage sensors
- Four temperature sensors
- Four current sensors
- 12 Form C relay outputs

4.2.1 System controller features

The Cordex® HP system controller has the following features:

- **Front touchscreen:** Full color touchscreen LCD panel, to access controls and menu items by using fingertip touch or a stylus.
- **Home button:** Provides the ability to go directly back to the home screen from any menu.
- **Front panel reset:** For emergency use only to restart the system controller if the LCD panel or home button are not responding.
- **Front panel LEDs:** For alarms, progress, and status indication.
- **Audio speaker:** Built-in audio tones during active alarms, and can be disabled if required.
- **Ethernet:** Dual port 10/100 BASE-T Ethernet connections on both the front and rear of the system controller for remote or local communication.
- **USB:** Dual ports on both the front and rear of the system controller for upgrades and file management via a standard USB flash drive.
- **CAN:** Dual independent CAN bus ports for communication with the EnerSys® systems, modules, and peripherals.
- **Real-time clock with field replaceable lithium battery:** Allows for timestamps on alarms and events.
- **System fail alarm/relay:** Activates when there is a major internal failure. During such a condition the system controller attempts to reset.

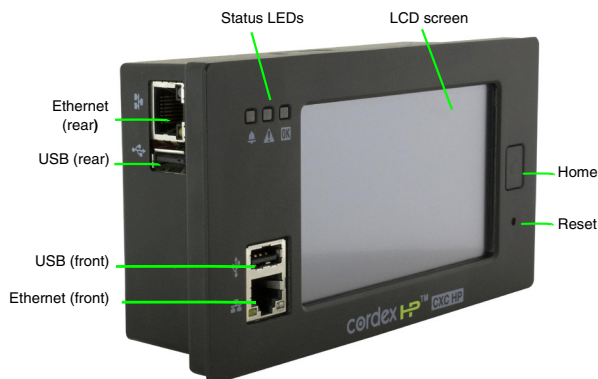

Figure 17: Cordex® CXC HP system controller

4.3 External peripherals

4.3.1 Cordex® HP L-ADIO Low Voltage Smart Peripheral

The Cordex® HP L-ADIO low voltage smart peripheral is the standard analog and digital I/O peripheral for low voltage (<60VDC) systems. The peripheral communicates on CAN bus to the system controller and provides user access to I/O management via the system controller.

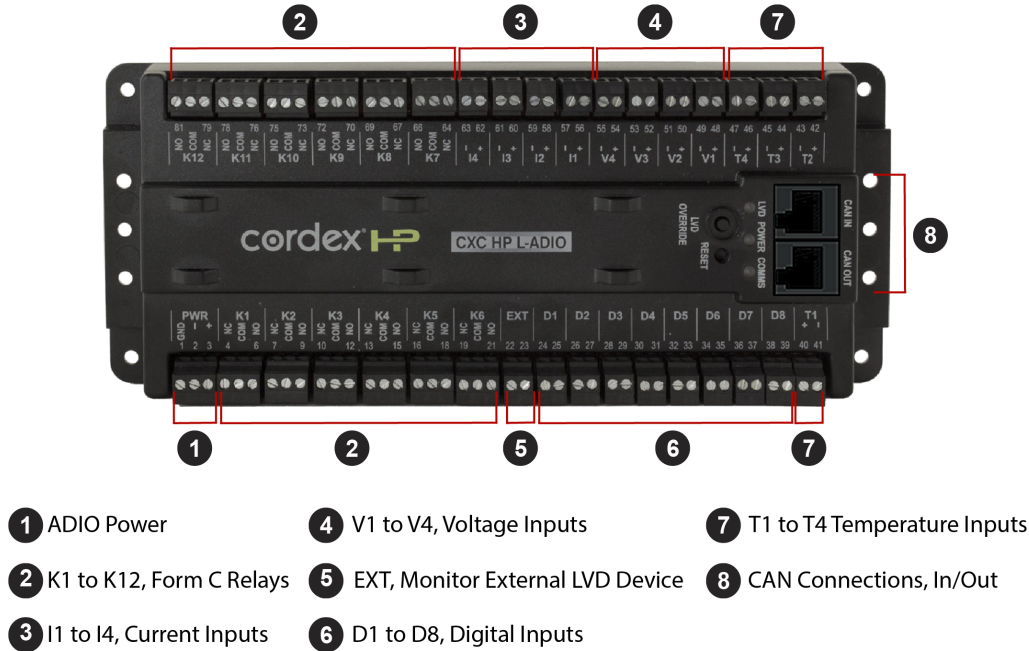

Figure 18: Cordex® HP L-ADIO low voltage smart peripheral

Analog inputs

Four voltage inputs, V1 to V4, are provided for a variety of voltage monitoring requirements. The input channels can measure a signal between -60 to $+60$ VDC.

Four current input channels, I1 to I4, provide monitoring of current; for example, discharge (load) and charge (battery). The system controller is capable of monitoring standard shunts of 25, 50, and 100 mV as well as application specifications of up to 250 mV. The shunt current rating can be configured via the system controller and is set by default to 800A 25mV. The input range for this signal is -250 to $+250$ mV.

Four temperature input channels, T1 to T4, provide monitoring of temperature probes (thermistors). These are typically used for either ambient temperature, or for battery post monitoring to enable battery temperature compensation. The temperature sensor is provided by Alpha® in various lengths. The input range for this signal is 0 to 5 volts and is powered internally from the peripheral.

Digital inputs

The peripheral can accommodate up to eight digital input channels, D1 to D8. Each channel responds to a zero or system voltage potential at the input to activate or deactivate the appropriate condition.

These channels can monitor digital alarm and control signals from rectifier modules, converter modules, and many other types of equipment.

An additional digital input, EXT is reserved for monitoring an external LVD override.

Alarm and control output relays

Each peripheral contains 12 Form C alarm output relays to extend alarms and to control external apparatus. Each internally generated alarm or control signal may be mapped to any one of the 12 relays, several signals may be mapped to just one relay or none at all.

LED status

Each peripheral contains three LEDs for peripheral status indication. See the [Troubleshooting](#) section for LED states and meanings.

Front panel reset button



NOTICE

Pressing the reset button will cause the peripheral to lose communication with the system controller.

A reset button is located on the front panel. It takes approximately 15 seconds before the unit is reacquired after pressing the reset button.

During a reset condition, the peripheral will keep relays in their last known state to prevent false alarm notifications and possible changing system LVD states.

LVD override

An LVD override button is provided to keep any relays assigned to LVD function in a static state. The override function should be used whenever performing system controller maintenance such as test relay functions, or when replacing a system controller.

To engage the LVD override function, press and hold the LVD button for three seconds. A yellow LED will signal that the override is engaged. To restore back to normal LVD operation, press and hold the LVD button again for three seconds.

4.3.2 Cordex® HP 6i-ADIO Six Input Smart Peripheral

The Cordex® HP 6i-ADIO six input smart peripheral is an analog input peripheral providing six isolated shunt inputs. It communicates on CAN bus to the system controller and provides access to shunt inputs via the system controller.



Figure 19: Cordex® HP 6i-ADIO six input smart peripheral

4.4 Cordex® HP 4.0/4.6 kW Rectifier Shelves

4.4.1 Rectifier module features

- High performance 83.3A rectifier module for 48V telecom applications.
- High efficiency rectifier modules for reduced operating expense and carbon footprint.
- High power density 4RU form factor delivering up to 24kW per 23-inch shelf.
- Power limiting and wide range AC input for global installation requirements.
- Extended operating temperature range for deployment in the harshest outdoor environments.



Figure 20: Cordex® HP 4.0 kW rectifier module

4.4.2 Front access system: AC wiring

The Cordex® HP 4.0/4.6kW rectifier shelves used within the power system are 23 inches in width. The individual rectifier shelves are wired to the AC power distribution panel provided by the customer. The AC input wiring is routed from the top chassis conduit knockouts and through the inner wire ducts on the sides of the DC distribution area to the front accessible AC terminal block assembly. The AC wiring size depends upon the rectifier shelf input voltage configuration and local electrical code.

The recommended AC circuit breaker size, wire gauge, and conduit trade sizes are as follows:

Table B: Canadian Electrical Code (CEC) conduit size input feed

Rectifier modules per conduit	Rectifier modules per feed	Min. external breaker	Wire gauge	Min. conductor rating ¹	Conductors per conduit ^{1,2}	Conduit trade size
7 or 8	1 (1P, 2W)	30A	8 AWG (10 mm ²)	55A × 0.91 × 0.7 = 35A rating	Recommended: 17 Maximum: 21	1-½ inch
6 to 8	2 (1P, 2W)	60A	6 AWG (16 mm ²)	75A × 0.91 × 0.7 = 48A rating	Recommended: 9 Maximum: 15	1-½ inch
6 to 9	3 (3P, 4W)	30A	8 AWG (10 mm ²)	55A × 0.91 × 0.7 = 35A rating	Recommended: 13 Maximum: 21	1-½ inch
6 to 9	3 (3P, 3W)	50A	6 AWG (16 mm ²)	75A × 0.91 × 0.7 = 48A rating	Recommended: 10 Maximum: 15	1-½ inch

¹ Based on CEC 194°F (90°C) conductor, 104°F (40°C) ambient and number of wires in conduit.

² Including one ground per conduit.

Table C: National Electrical Code (NEC®) conduit size input feed

Rectifier modules per conduit	Rectifier modules per feed	Min. external breaker	Wire gauge	Min. conductor rating ¹	Conductors per conduit ^{1,2}	Conduit trade size
7 or 8	1 (1P, 2W)	30A	8 AWG (10 mm ²)	55A × 0.91 × 0.7 = 35A rating	Recommended: 17 Maximum: 21	1-½ inch
6	2 (1P, 2W)	60A	6 AWG (16 mm ²)	75A × 0.91 × 0.7 = 48A rating	Recommended: 7 Maximum: 7	1 inch
3 to 6	3 (3P, 4W)	30A	8 AWG (10 mm ²)	55A × 0.91 × 0.7 = 35A rating	Recommended: 9 Maximum: 9	1 inch

3 to 6	3 (3P, 3W)	50A	6 AWG (16 mm ²)	75A × 0.91 × 0.7 = 48A rating	Recommended: 7 Maximum: 7	1 inch
¹ Based on NEC® 194°F (90°C) conductor, 104°F (40°C) ambient and number of wires in conduit. ² Including one ground per conduit.						

4.4.3 Standard system: AC wiring

The Cordex® HP 4.0/4.6kW rectifier shelves used in the power system are 23 inches in width. The individual rectifier shelves are wired to the AC power distribution panel provided by the customer. The AC input wiring is routed through a one inch trade size conduit knockout on the side of the shelf to a terminal block connection. The AC wiring size depends upon the rectifier shelf input voltage configuration and local electrical code.

The recommended AC circuit breaker size and wire gauge are as follows:

Rectifier shelf	Recommended AC breaker size	Recommended AC wire gauge
1-phase 208 to 277VAC	6 × 30A AC breakers	10 AWG (6 mm ²)
3-phase 208VAC (without neutral)	2 × 50A AC breakers	6 AWG (16 mm ²)
3-phase 277/480VAC (with neutral)	2 × 30A AC breakers	10 AWG (6 mm ²)

4.4.4 LEDs

The three LEDs on the rectifier module front panel indicate status. See the [Troubleshooting](#) section for LED states and meanings.

4.4.5 Cordex® HP 4.0/4.6 kW Rectifier Shelf busing

The power system accepts from one to five Cordex® HP 4.0/4.6kW rectifier shelves:

- One Cordex® HP 4.0/4.6kW rectifier shelf kit
- Two Cordex® HP 4.0/4.6kW rectifier shelf kits
- Three Cordex® HP 4.0/4.6kW rectifier shelf kits
- Four Cordex® HP 4.0/4.6kW rectifier shelf kits
- Five Cordex® HP 4.0/4.6kW rectifier shelf kits

The rectifier shelf busing kit includes the busbars to connect the rectifier shelves to the distribution module and the Kydex® cover to insulate the busbars.

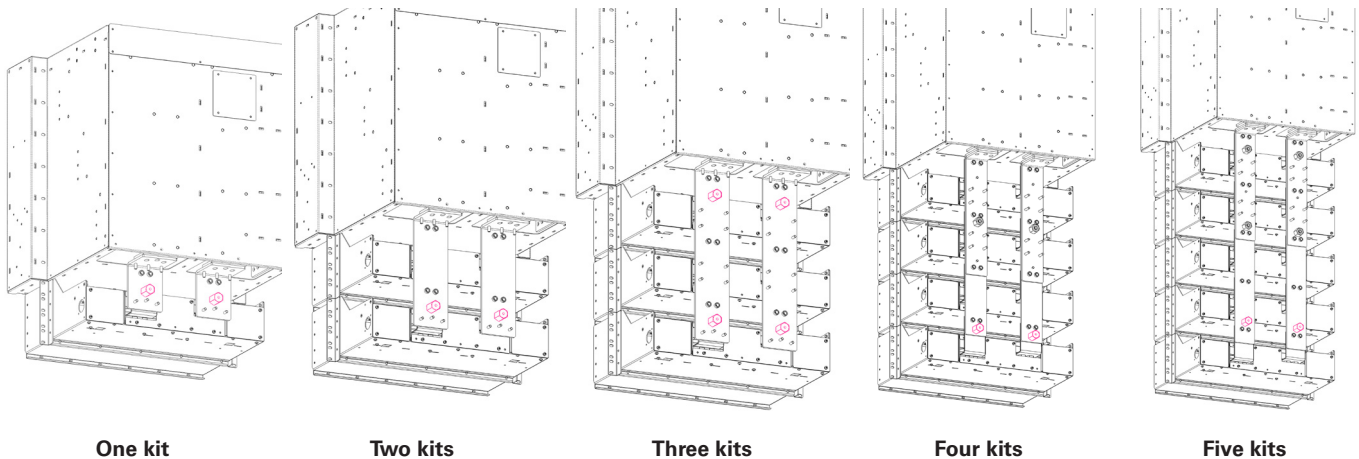

Figure 21: Cordex® HP 4.0/4.6 kW rectifier shelf busing

4.5 Cordex® HP 2.4/3.0kW Rectifier Shelves

4.5.1 Rectifier module features

- High performance compact 50 or 62.5A rectifier module for 48VDC telecom applications.
- High efficiency rectifier modules for reduced operating expense and carbon footprint.
- High temperature operating range for installation in non-controlled environments.
- Multiple configurations providing 250A, 12kW/312.5A, or 15kW in a compact 1RU form factor.
- Wide AC input operating range for global installation requirements.
- Extended operating temperature range for deployment in the harshest outdoor environments.

4.5.2 Front access: AC wiring

The Cordex® HP 2.4/3.0kW rectifier shelves used within the power system are 23 inches in width. The individual rectifier shelves are wired to the AC power distribution panel provided by the customer. The AC input wiring is routed from the top chassis conduit knockouts and through the inner wire ducts on the sides of the DC distribution area to the front accessible AC terminal block assembly. The AC wiring size depends upon the rectifier shelf input voltage configuration and local electrical code.

The recommended AC circuit breaker size, wire gauge, and conduit trade sizes are as follows:

Table E: Canadian Electrical Code (CEC) conduit size input feed

Rectifier modules per conduit	Rectifier modules per feed	Min. external breaker	Wire gauge	Min. conductor rating	Conductors per conduit ^{1,2}	Conduit trade size
6 to 10	2 (1P, 2W)	40A	8 AWG (10 mm ²)	55A × 0.91 × 0.7 = 35A rating	Recommended: 13 Maximum: 21	1-½ inch
	1 (1P, 2W)	20A	12 AWG (4 mm ²)	30A × 0.91 × 0.7 = 19A rating		
¹ Based on CEC 194°F (90°C) conductor, 104°F (40°C) ambient and number of wires in conduit. ² Including one ground per conduit.						

Table F: National Electrical Code (NEC®) conduit size input feed

Rectifier modules per conduit	Rectifier modules per feed	Min. external breaker	Wire gauge	Min. conductor rating	Conductors per conduit ^{1,2}	Conduit trade size
3 to 6	2 (1P, 2W)	40A	8 AWG (10 mm ²)	55A × 0.91 × 0.7 = 35A rating	Recommended: 9 Maximum: 9	1 inch
	1 (1P, 2W)	20A	12 AWG (4 mm ²)	30A × 0.91 × 0.7 = 19A rating		
¹ Based on NEC® 194°F (90°C) conductor, 104°F (40°C) ambient and number of wires in conduit. ² Including one ground per conduit.						

4.5.3 Standard system: AC wiring

The Cordex® HP 2.4/3.0kW rectifier shelves used in the power system are 23 inches in width. The individual rectifier shelves are wired to the AC power distribution panel provided by the customer. The AC input wiring is routed through a one inch trade size conduit knockout on the side of the shelf to a terminal block connection. The AC wiring size can vary based on local electrical code.

The recommended AC circuit breaker size and wire gauge are as follows:

Table G: Recommended AC breaker size and wire gauge		
Rectifier shelf	Recommended AC breaker size	Recommended AC wire gauge
1-phase 208 to 277VAC	2 × 40A AC breakers	8 AWG (10 mm ²) for 40A breaker
	1 × 20A AC breakers	12 AWG (4 mm ²) for 20A breaker

4.5.4 LEDs

The three LEDs on the rectifier module front panel indicate status. See the [Troubleshooting](#) section for LED states and meanings.

4.5.5 Cordex® HP 2.4/3.0kW Rectifier Shelf busing

The power system accepts from two to five Cordex® HP 2.4/3.0kW rectifier shelves. Additional rectifier shelves can be added in the field to a live system. The following rectifier shelf kits are available:

- Two Cordex® HP 2.4/3.0kW rectifier shelf kits
- Three Cordex® HP 2.4/3.0kW rectifier shelf kits
- Four Cordex® HP 2.4/3.0kW rectifier shelf kits
- Five Cordex® HP 2.4/3.0kW rectifier shelf kits

The rectifier shelf busing kit includes the busbars to connect the rectifier shelves to the distribution module and the Kydex® cover to insulate the busbars.

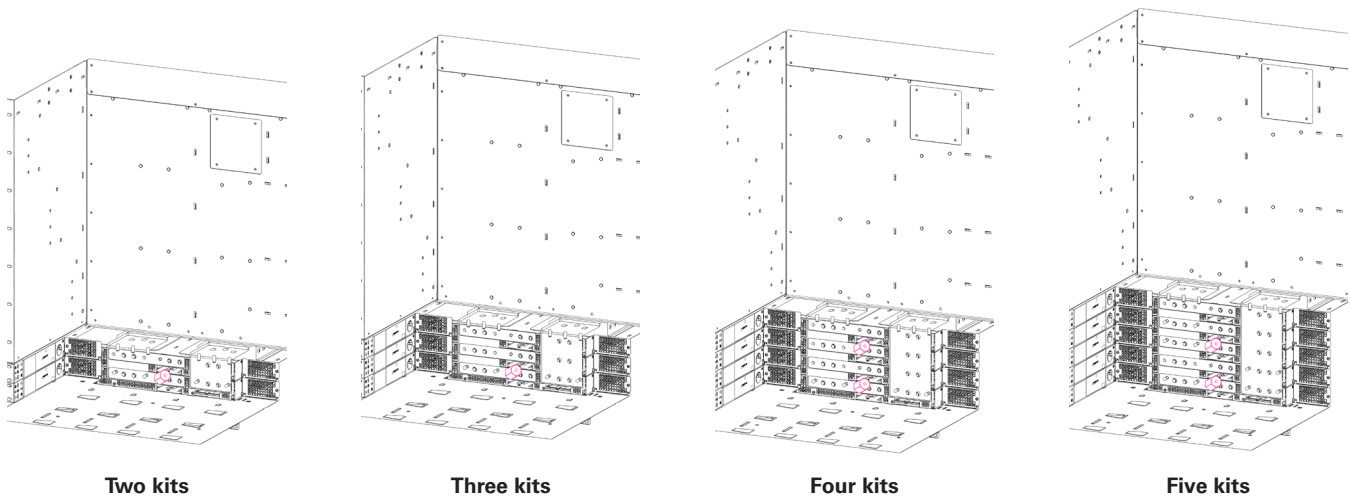

Figure 22: Cordex® HP 2.4/3.0kW rectifier shelf busing

4.6 Integrated battery trays

The power system is designed to integrate battery trays installed below the power system. These battery trays can accept standard 12V monoblocks ranging in height from 6 to 8RU. The battery trays are factory installed and pre-wired for ease of installation. They can be configured with or without battery circuit breakers as overcurrent protection devices (OCPD). The battery circuit breakers are installed in a circuit breaker housing on the side of each battery tray. The breaker sizes and its associated cabling can range from 100 to 250A.

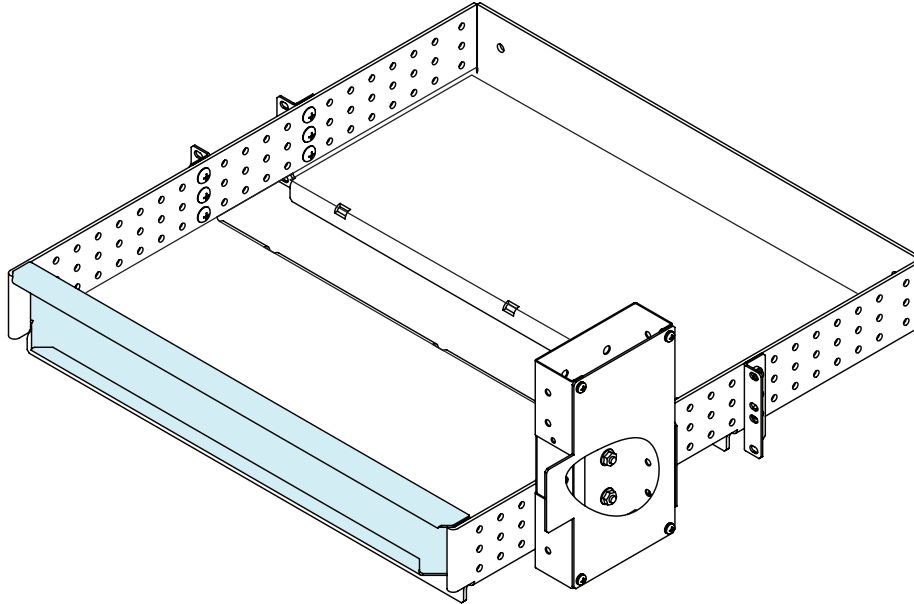

Figure 23: Integrated battery tray

When battery trays are ordered for systems without a low voltage battery disconnect (LVBD), the battery cable landing busbar kit will need to be ordered. This kit provides a secure location to terminate each individual battery tray cable to the main power system bus enabling a clean install. In addition, this kit provides sufficient access to customers in the event that a battery tray and its associated cabling needs to be added in the field on a live plant.

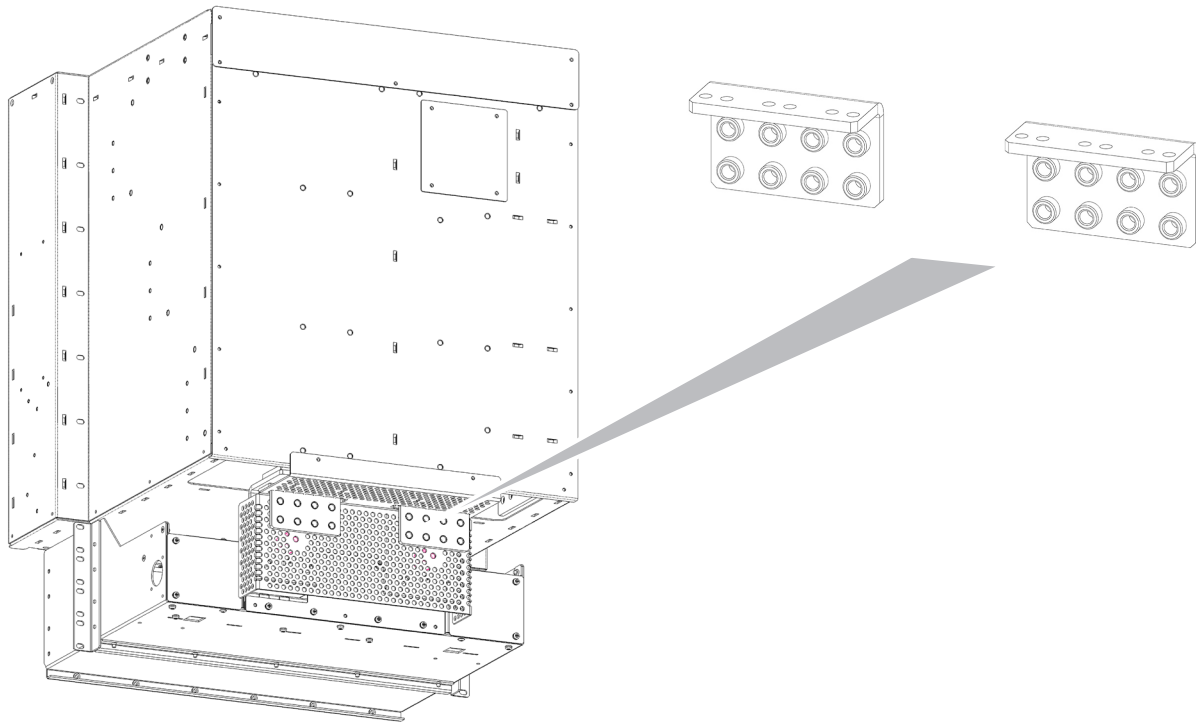

Figure 24: Battery cable landing busbars

4.7 Remote return bar kit

The external return bar kit is an alternate option for landing return connections from the loads. It serves as the common connection point for the positive side of the power section and the batteries. The power system remote return bar has a capacity of 2,500A per kit. Adder kits with a capacity of 2,500A can be installed onto the base kit to increase its total capacity.

Each bar provides 62 × ½ inch holes on 1 ¾ inch centers, 62 × ⅜ inch holes on 1 inch centers, and 60 × ¼ inch holes on ⅝ inch centers.

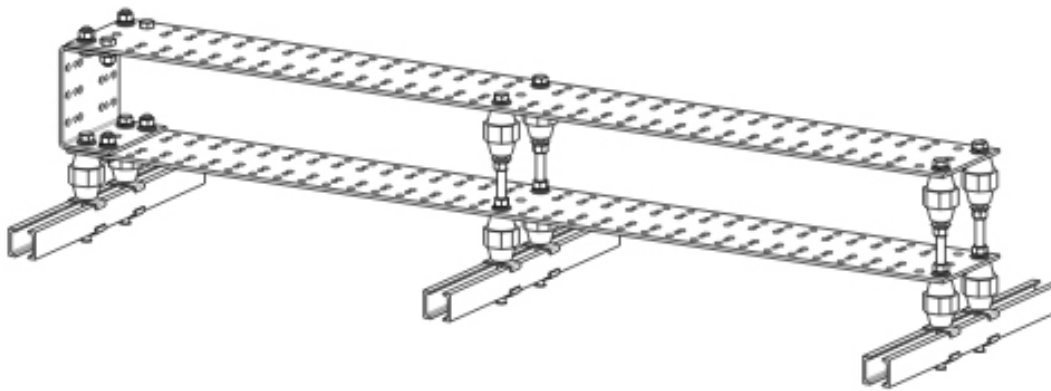

Figure 25: Remote return bar kit

The kits can be ordered with optional insulative covers as shown in the following image.

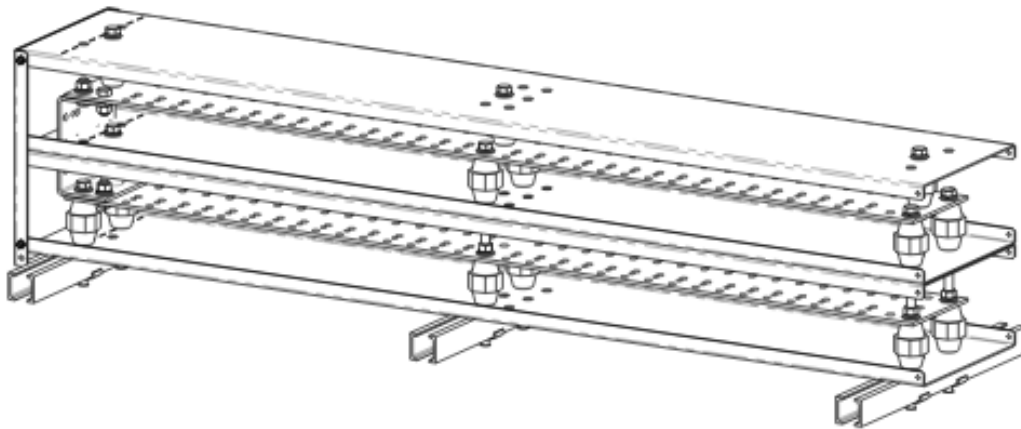

Figure 26: Remote return bar kit with optional insulative covers

4.7.1 Interbay busing

- The interbay busing option provides the user the capability to field expand a 1,200 or 2,000A power system to a 2,400 or 4,000A system.
- The new, higher capacity system will still maintain one centralized system controller in the primary bay.
- The supplemental expansion bay can be added either to the left or right of the primary power and distribution bay.
- This interbay busing option can be added live without loss of service.
- A maximum of one supplemental bay can be added for each primary bay.

NOTICE

Limitation: The interbay busing cannot be used on systems that utilize the rectifier shelf field expansion kit.

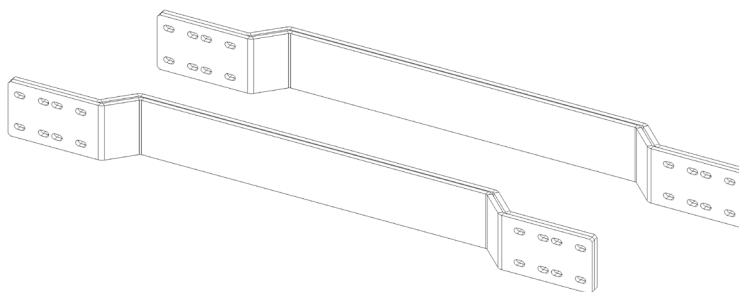

Figure 27: Interbay busing (2,000A shown here)

5. Inspection

5.1 Packaging materials

Alpha Technologies Ltd. is committed to providing products and services that meet our customers' needs and expectations in a sustainable manner, while complying with all relevant regulatory requirements. As such we strive to follow quality and environmental objectives from product supply and development through to the packaging for our products.

Power modules and batteries are shipped on individual pallets and are packaged according to the manufacturer's guidelines.

Almost all packaging material is from sustainable resources and or is recyclable.

5.2 Returns for service



NOTICE

Alpha Technologies Ltd. is not responsible for damage caused by improper packaging of returned products.

Save the original shipping container. If the product needs to be returned for service, it should be packaged in its original shipping container. If the original container is unavailable, make sure that the product is packed with at least three inches of shock-absorbing material to prevent shipping damage.

5.3 Check for damage

Before unpacking the product, note any damage to the shipping container. Unpack the product and inspect the exterior for damage. If any damage is observed, contact the carrier immediately. Continue the inspection for any internal damage. In the unlikely event of internal damage, inform the carrier and contact us for advice on the impact of any damage.

5.4 General receipt of shipment

The inventory included with your shipment depends on the options you have ordered.

6. Installation

Only qualified personnel should install and connect the power components in the Cordex® power system. For the battery installation, refer primarily to the manufacturer's documentation.

Reference is made to drawings located at the end of this document. Layout and schematic drawings are provided with the power system.



ATTENTION

Cordex® CXPS-W-FA, CXPS-W 2,000A power systems must be installed above a non-combustible surface.

6.1 Safety precautions

Refer to the [Safety](#) section near the beginning of this document.

6.2 Tools required

Various insulated tools are essential for the installation. Use this list as a guide:

- Battery lifting apparatus if required
- Electric drill with hammer action, ½ inch capacity
- Various crimping tools and dies to match lugs used in installation
- Load bank of sufficient capacity to load largest rectifier module to its current limit
- Digital voltmeter equipped with test leads
- Cable cutters
- Torque wrench: ¼ inch drive, 0 to 150 in-lb (0 to 17 Nm)
- Torque wrench: ⅜ inch drive, 0 to 100 ft-lb (0 to 135 Nm)
- Insulating canvases as required
- Various insulated hand tools including:
 - Combination wrenches, ratchet and socket set
 - Various screwdrivers, electricians knife
- Battery safety spill kit required for wet cells only
- Cutters and wire strippers 6 to 22 AWG (16 to 0.34 mm²)

6.3 Installation of external batteries



WARNING

Follow the battery manufacturer's safety recommendations when working around battery systems and review the safety instructions provided in this manual.

This information is provided as a guideline and is not meant to imply that batteries are part of this power system.

Batteries should be located in a temperature controlled environment, regulated to approximately 77°F (25°C). Significantly lower temperatures reduce performance and higher temperatures decrease life expectancy.

Provide adequate ventilation. Valve regulated lead acid (VRLA) batteries, though not requiring the special ventilation requirements of a flooded battery, should not be installed in an airtight enclosure. Hydrogen gas can be emitted from a failed battery.

If applicable, clean the cells before assembly according to the battery manufacturer's recommendations. First neutralize any acid with a baking soda and water solution; then wipe the cells with clean water.

6.3.1 Installation

Verify that all battery breakers, DC circuit breakers, and fuses on the distribution panels are either in the **OFF** position or removed.

Apply a corrosion-inhibiting agent, such as Sanchem Inc. NO-OX-ID® A-SPECIAL electrical grease, on all battery terminal connections.

1. If required, assemble the battery rack and the cells or monoblocks as per the installation instructions supplied with the batteries.
2. Ensure that the battery output cabling can reach the return [+] and hot [-] terminals of the series battery string and that the batteries are oriented correctly for easy installation of the inter-unit series connectors.
3. Remove any electrical grease from battery terminals.
4. Burnish the terminal posts with a non-metallic brush, polishing pad, or 3M Company Scotch-Brite® scouring pad.
5. Apply a light coating of electrical grease to the terminal posts.
6. If lead plated inter-unit connectors are used, they should also be burnished and electrical grease applied as directed. Install the inter-unit connectors.
7. After all battery connections are completed, torque the connections as per the battery specifications. Typically 100 in-lb (11.3 Nm).

Refer to the system startup procedure before connecting the batteries online.

6.5 Power system assembly and mounting

The power system must be mounted in a clean and dry environment. Sufficient free space must be provided at the front and rear of the power system. This is to meet the cooling requirements of the rectifier modules and to allow easy access to the power system components.

6.5.1 Weight and dimensions

The weight of the system with no rectifier or converter modules installed is approximately 650 lb (295 kg).

6.5.2 Floor mounted systems



NOTICE

It is extremely important that the bay be properly shimmed to prevent any frame distortion. If the floor is not level, shims may be required.

Secure the system to a concrete floor using either heavy duty anchors (1/2 inch x 2 1/2 inch), or for wooden floors, heavy duty lag screws (5/8 inch x 2 1/2 inch). Use appropriately sized flat washers.

If required, use isolation kits to isolate the system from the floor.

Secure the relay rack to the overhead cable tray. Alpha® does not supply the mechanical details necessary for overhead support.

1. Place the bay in position over the anchoring holes (and the isolation pad if necessary).
2. Install the anchoring hardware for each anchor finger-tight.
3. Check that the bay is level front to back and side to side. Install shims if necessary.
4. Once the bay is level, tighten all bolts to the appropriate torque.

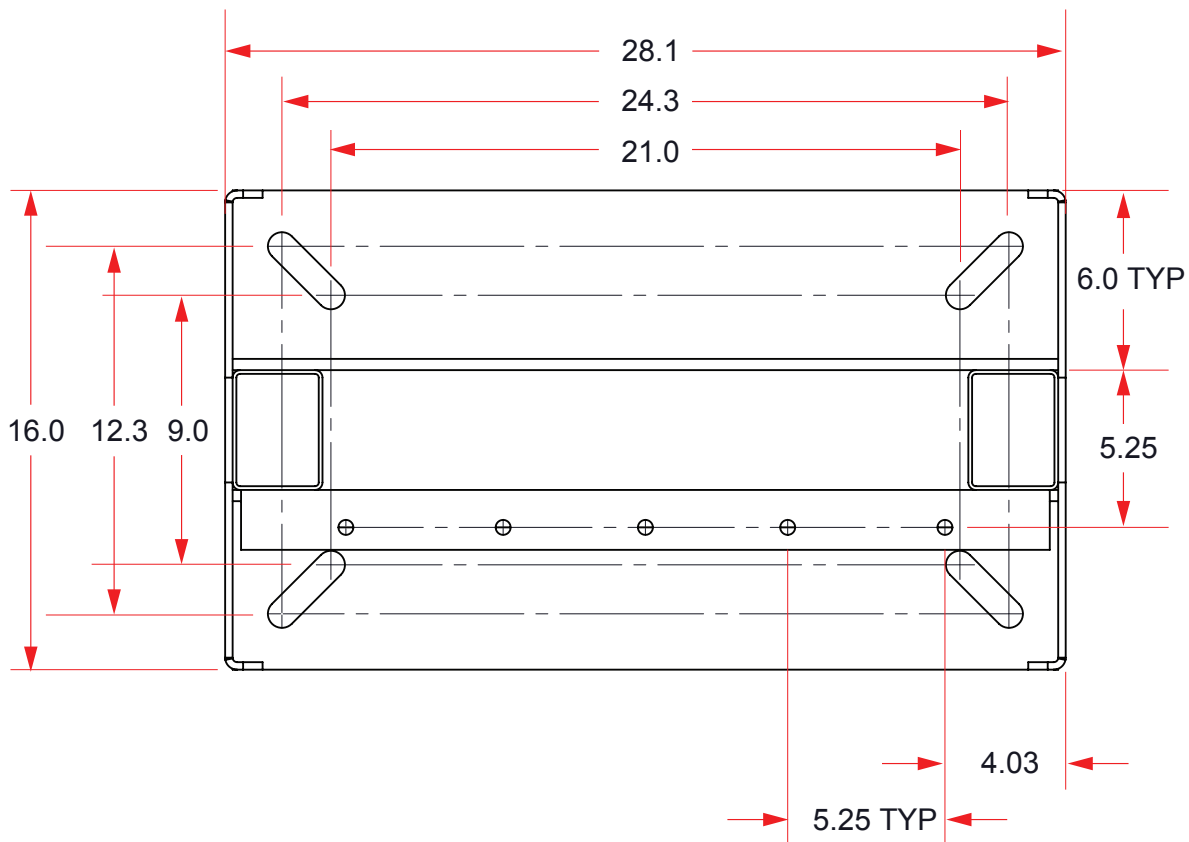

Figure 28: Rack mounting details (top view), welded rack

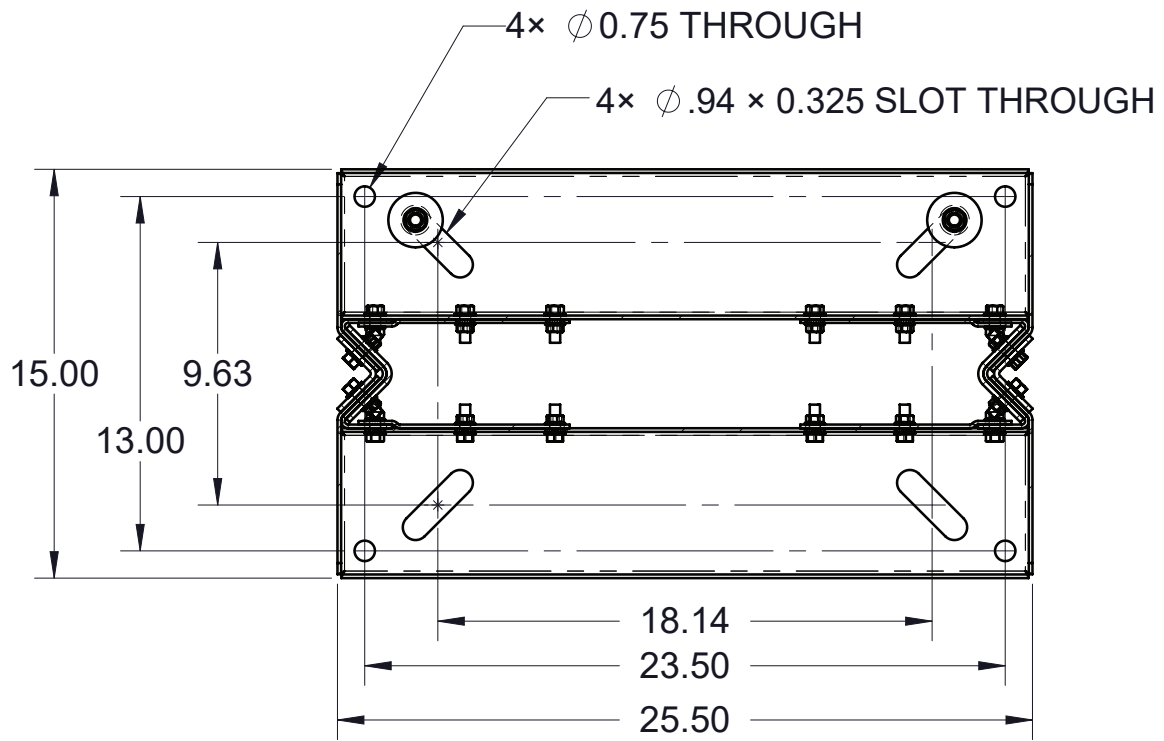

Figure 29: Rack mounting details (top view), bolted rack

7. Wiring

This section provides cabling details and notes on cable sizing for DC applications with respect to the product.



WARNING

Ensure that the power is switched off by switching off rectifier modules and removing battery line fuses, turn off battery circuit breakers before attempting work on the wiring. Use a voltmeter to verify the absence of a voltage. Clearly mark the correct polarity of the battery leads before starting work on DC connections.

7.1 Installation notes

Refer to the installation section for safety precautions and tools required.

7.1.1 Calculating input and output wire size requirements

Although DC power wiring and cabling in telecommunication applications tend to exceed electrical code requirements, mostly due to the voltage drop requirements, all applicable electrical codes take precedence over the guidelines and procedures in the present chapter, wherever applicable.

Wire size is calculated by first determining the appropriate maximum voltage drop requirement. Use the following formula to calculate the circular mil area (CMA) wire size requirement. Determine the size and number of conductors required to satisfy the CMA requirement.

$$\text{CMA} = (\text{A} \times \text{LF} \times \text{K}) / \text{AVD}$$

A = Ultimate drain in amps.

LF = Conductor loop feet.

K = 11.1 constant factor for commercial (TW type) copper wire.

AVD = Allowable voltage drop.

Check again that the ampacity rating of the cable meets the requirement for the installation application. Consult local electrical codes (for example, National Electrical Code® and Canadian Electrical Code) for guidelines. If required, increase the size of the cable to meet the code.

Refer to [Table I](#) for cable size equivalents.

Table I: Cable size equivalents (Imperial to Metric)

American Wire Gauge	Circular mils	Square millimeters	Equivalent metric cable
20 AWG	1020	0.519	1
18 AWG	1624	0.8232	1
16 AWG	2583	1.309	1.5
14 AWG	4107	2.081	2.5
12 AWG	6530	3.309	4
10 AWG	10380	5.261	6
8 AWG	16510	8.368	10
6 AWG	26250	13.30	16
4 AWG	41740	21.15	25
2 AWG	66370	33.63	35
0 AWG (or 1/0)	105600	53.48	50 or 70
00 AWG (or 2/0)	133100	67.42	70
0000 AWG (or 4/0)	211600	107.2	120
313 MCM (or kcmil)	313600	159	150 or 185

American Wire Gauge	Circular mils	Square millimeters	Equivalent metric cable
350 MCM (or kcmil)	350000	177.36	185
373 MCM (or kcmil)	373700	189	185 or 240
500 MCM (or kcmil)	500000	253.36	300
535 MCM (or kcmil)	535300	271	300
750 MCM (or kcmil)	750000	380.00	400
777 MCM (or kcmil)	777700	394	400

7.1.2 Required torque values

[Table J](#) lists the recommended torque values for connection to the power system with the following hardware:

- Clear hole connections (nut and bolt)
- PEM studs
- PEM threaded inserts
- Thread formed connections (in copper busbar)

SAE Grade 5 rated hardware is required for these torque values. Use factory provided hardware. Stainless or other metals have a different torque specification.

Size	Torque value
¼ inch	8.8 ft-lb (11.93 Nm)
⅜ inch	32.5 ft-lb (44.06 Nm)
½ inch	73 ft-lb (98.97 Nm)

7.2 Grounding

Connect the isolated power system battery return bus (BRB) to the building master ground bus (MGB), or floor ground bus (FGB) in a larger building. This acts as a system reference and as a low impedance path to the ground for surges, transients and noise. The MGB or FGB must have a direct low impedance path to the building grounding system.

The cable from the power system to the MGB or FGB must be sized to provide sufficient ampacity to clear the largest fuse or circuit breaker on the power system, excluding the battery protection fuse or circuit breaker. This is the minimum requirement. Other factors including length of cable and special grounding requirements of the load must also be factored in. The insulated cable must be equipped with two-hole crimp type lugs and must not have any tight bends or kinks.

Power system ampacity	Recommended ground reference conductor size
<30A	10 AWG (6 mm ²)
30 to 100A	6 to 2 AWG (16 to 35 mm ²)
100 to 400A	0000 AWG (107 mm ²)
400 to 800A	350 MCM (185 mm ²)
>800A	750 MCM (400 mm ²)

The power system frame must also be connected to the MGB or FGB. This is done for personnel safety and to meet many telecom grounding requirements. Each bay must have its own frame or site ground connection. Refer to the customer connection drawing at the end of this document.

7.2.1 Frame ground

The power plant frame must be connected to the MGB or FGB. This connection is necessary for personnel safety and to meet many telecom grounding requirements.

Use 2 AWG (35 mm²) or 0 AWG (50 mm²) wiring for frame ground.

Remove paint in lug contact area to ensure a good electrical connection.

Connection to overhead trays

The rack upper crossbar ([Figure 29](#)) has three to five $\frac{5}{8}$ inch diameter holes to accommodate threaded rod attachment to the overhead trays.

Five $\frac{5}{8}$ inch diameter holes for connections to the overhead trays

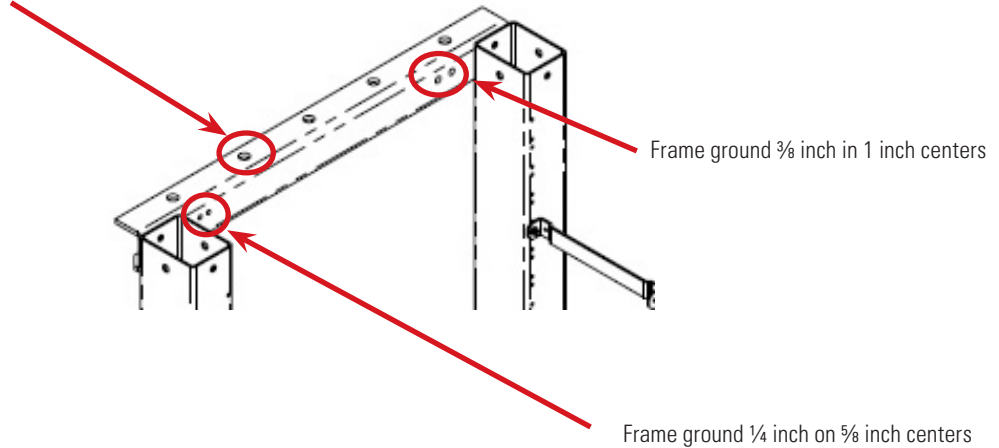

Figure 30: Connecting the frame ground

7.3 Front access system: AC supply wiring

To avoid future accessibility issues, connect the AC circuits to all rectifier shelves at the time of installation



NOTICE

Verify no rectifier modules are installed in the rectifier shelves at this time.

7.3.1 AC input terminal block assembly

To access the AC input terminal block assembly, loosen the two front screws and the two rear screws on the AC terminal block top front cover as shown. Use the top front cover rounded finger openings to lift up and slide out the cover completely.

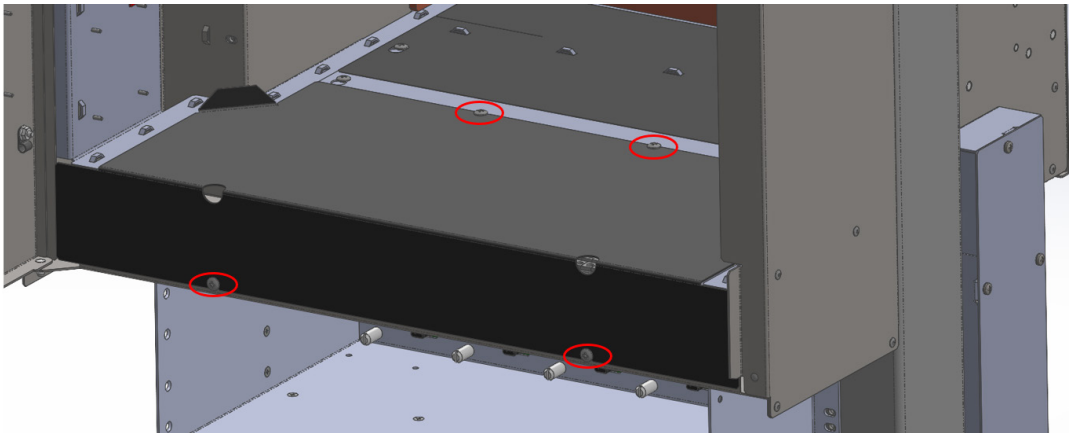

Figure 31: AC input terminal block top front cover

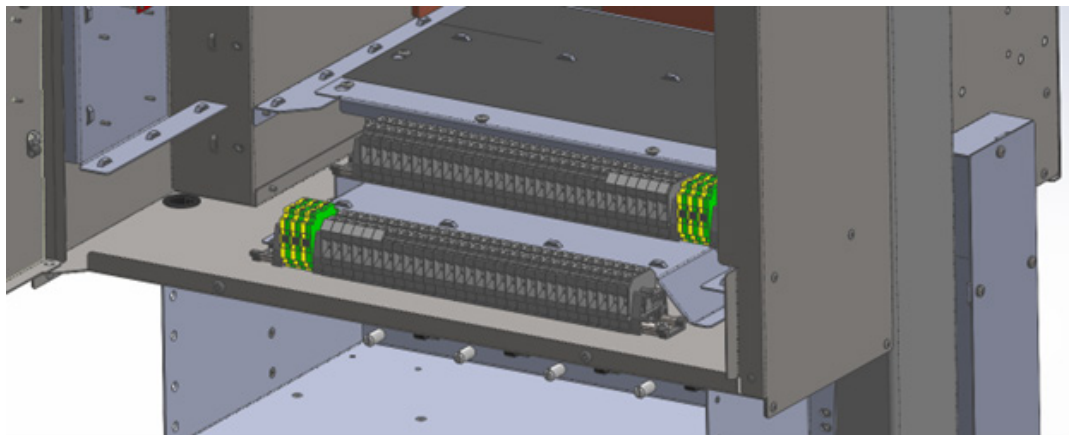

Figure 32: AC input terminal block with top front cover removed (your system may have fewer terminal blocks than is shown)

7.3.2 Top chassis conduit entry plate

Two sizes of conduit knockouts are available on the top chassis conduit entry plate. Select and install the appropriate size conduit fitting and quantity for your application. Refer to conduit size tables in the previous AC wiring front access system section. A grounding conductor must be provided with each conduit run. Check your specific rectifier shelf AC input voltage configuration for wiring requirements in [section 7.5.5](#), which shows the different rectifier shelf terminal block wiring configurations.

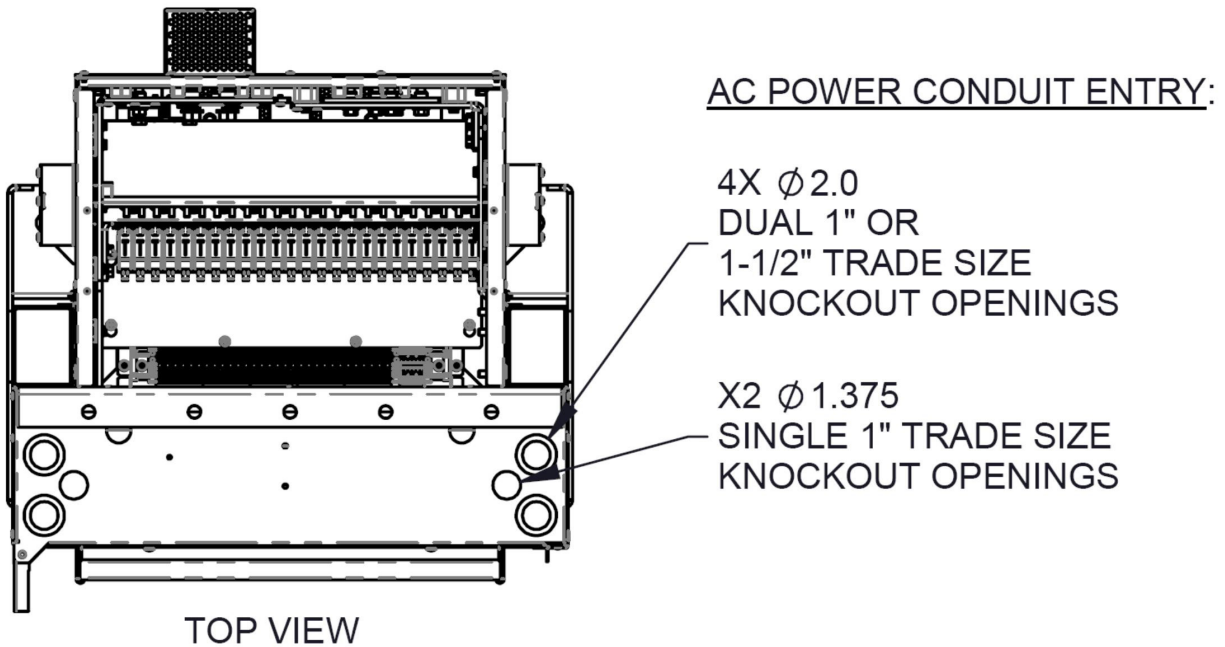

Figure 33: Top chassis conduit entry plate

7.3.3 AC input wire duct and cover

Remove the two AC input inner wire duct covers (on left and right sides) by removing the fasteners that secure each of them in place. Install conduit and fittings as required in the top chassis conduit entry plate.

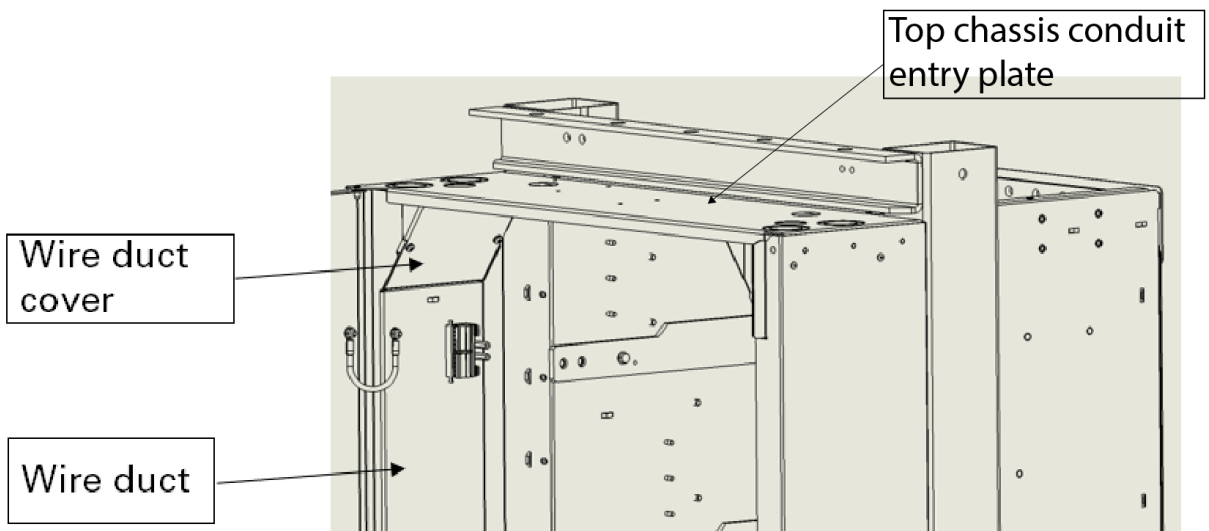

Figure 34: AC input wire ducts and covers

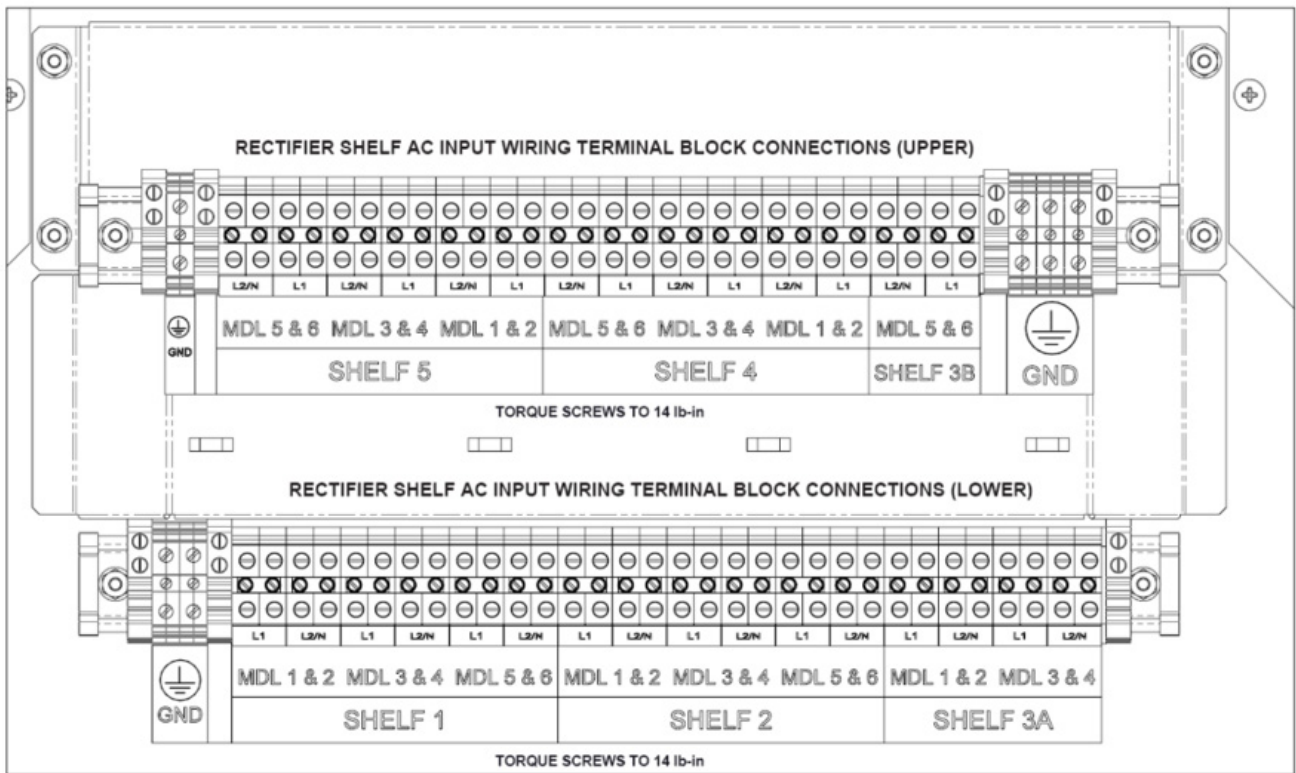

Figure 37: 4.0kW rectifier shelf AC input power wiring terminal block connections for 208 to 240 VAC, dual feed 1-phase option (typical)

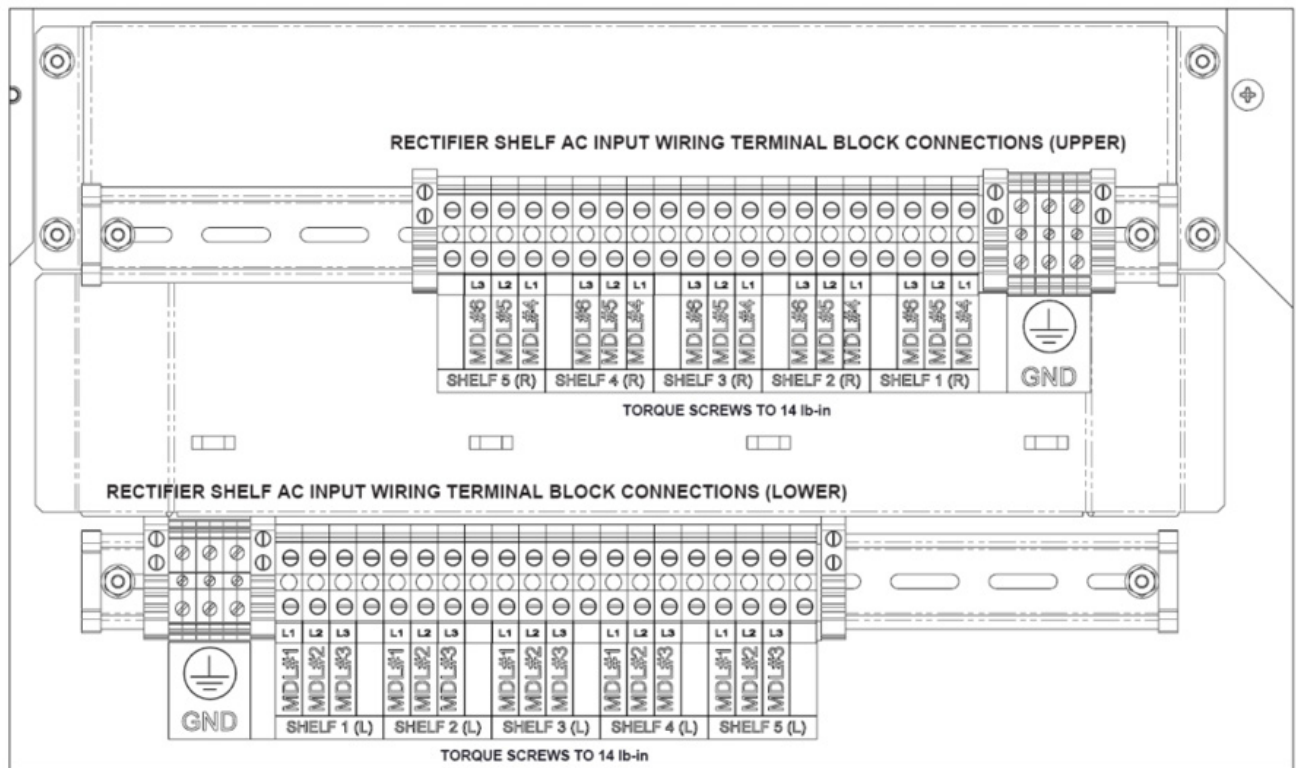

Figure 38: 4.0kW rectifier shelf AC input power wiring terminal block connections for 208 to 240 VAC, 3-phase 3-wire option (typical)

7.4 AC supply for the rectifier modules

To ease future access issues, connect the AC circuits to all rectifier shelves at the time of initial installation.



NOTICE

Verify no rectifier modules are installed in the rectifier shelves at this time.

7.4.1 Standard system: AC wiring for the Cordex® HP 4.0/4.6 kW Rectifier Shelf

The following figure shows the AC connections for one of the rectifier shelves. For other AC connection options (for example, 1-phase), refer to the rectifier shelf user guide that ships with your system.

Terminate flexible or rigid conduit at rectifier shelves; one connection on each side.

AC wire way 1.313 inch diameter hole for 1 inch trade size conduit

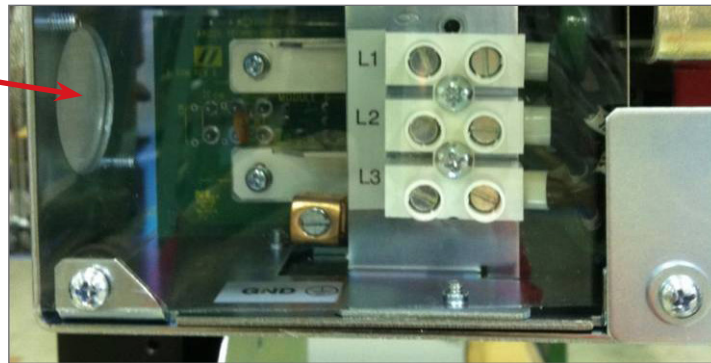

Figure 41: Shelf AC terminal block connection (3-phase, 3-wire shown with rear cover removed)

7.4.2 CAN bus termination for Cordex® HP 4.0/4.6 kW Rectifier Shelves

The CAN bus provides a communication path between the system controller and rectifier modules. In the power system, the CAN bus cabling is daisy chained from the Cordex® HP L-ADIO low voltage smart peripheral, to the top rectifier shelf. The cable is then daisy chained from the top rectifier shelf, to lower rectifier shelves, in sequence, see [Figure 32](#). At the last rectifier shelf, termination is enabled, see [Figure 31](#).

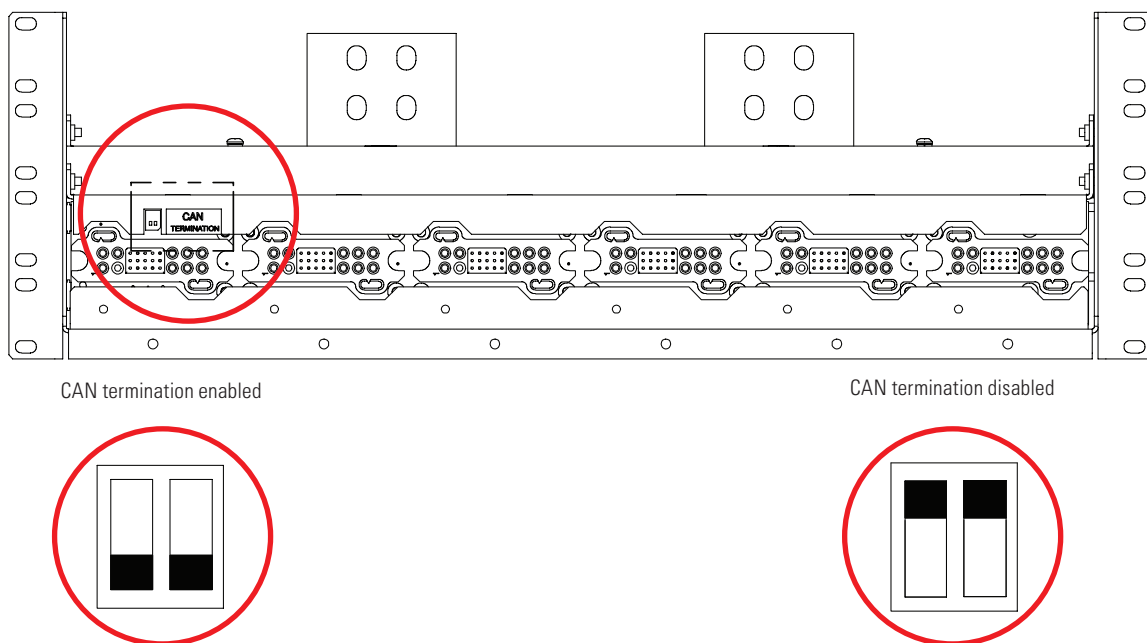

Figure 42: CAN bus termination

7.4.3 CAN bus termination for field power system capacity expansion (interbay busing link kit)



NOTICE

If your system has redundant rectifier modules, it is recommended to power off the left most rectifier module in the bottom shelf of the existing bay during this procedure.

1. Remove the left most rectifier module in the bottom shelf of the existing power system. Refer to the rectifier shelf user guide for the removal and re-insertion procedure.
2. Flip the DIP switches from Termination Enabled to Termination Disabled; see [Figure 31](#).
3. Replace the rectifier module.
4. Connect the CAN bus cable to the CAN OUT connector of the top rectifier shelf of the expansion power system; see [Figure 32](#).

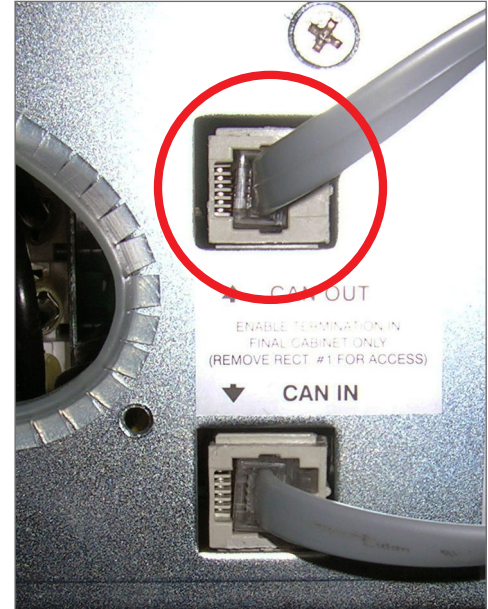

Figure 43: CAN IN and CAN OUT connections

7.5 Standard system: AC wiring for the Cordex® HP 2.4/3.0 kW Rectifier Shelf

7.5.1 AC feeder protection and sizing

To maximize system reliability, each feed should have a dedicated protection feeder breaker located at the AC distribution panel. The feeder breaker can also act as the disconnect device for the connected rectifier modules. Refer to the specifications for Alpha® breaker and wire size recommendations.



ATTENTION

To minimize EMI disturbances, route the AC input wires in flexible or rigid conduit and located as far away as possible from the DC power wires.

AC input connections



WARNING

Use care when removing or replacing the covers for the AC input connections. Never assume that an electrical connection or conductor is not energized.

1. Ensure that all rectifier modules are removed from the shelf.
2. At the rear of the shelf, remove the screw and flip the AC wire way cover down (two places) to access the AC input terminal blocks: each terminal pair corresponds to either two rectifier modules or a single rectifier module as shown in [Figure 33](#).
3. The AC wire way is designed for two customer-supplied, 1 inch trade size conduit fittings for the AC supplies located on each side of the shelf. Attach the conduit fittings to the wire way holes and route the AC wires through them.
4. Secure the appropriate signal wires to the AC input terminal blocks and AC ground terminals. Refer to the customer connection drawing at the end of the document where applicable.
5. Tighten the cable fitting/connector to the AC cable (conduit or similar).
6. Replace the rear covers once all connections have been completed.



NOTICE

Rectifier shelf slots are numbered 1 to 5 from the left front of the shelf.

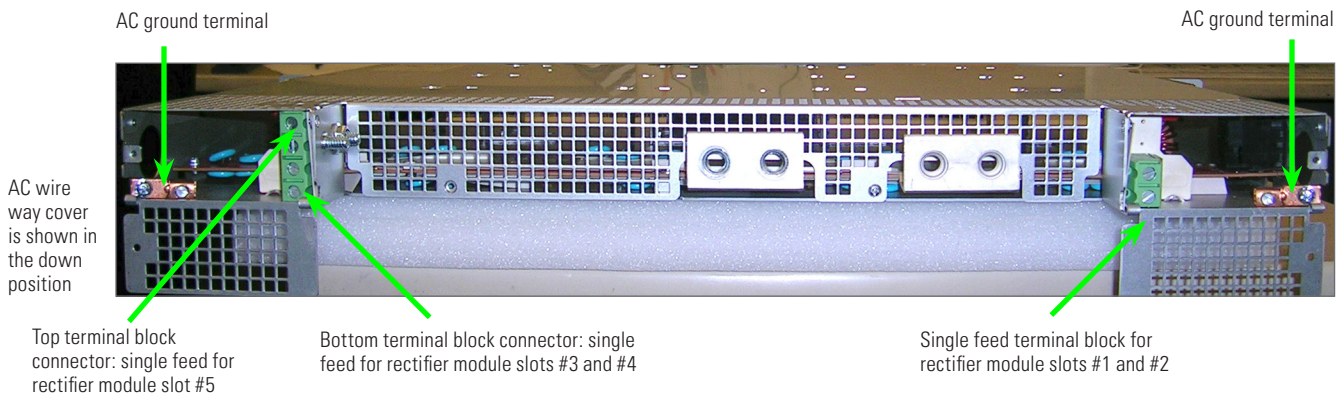

Figure 44: AC input power and ground wire connections for 23-inch shelf

7.5.2 CAN bus termination for Cordex® HP 2.4/3.0kW Rectifier Shelves

Two CAN serial ports (modular jacks with offset latches), are provided for communications with rectifier modules and other CAN enabled equipment. These are located on the left-side of the rectifier shelf as viewed from the front.

1. Daisy chain CAN serial ports from shelf to shelf (CAN OUT of one shelf to CAN IN of another).
2. Insert a terminator (PN: 5450228-001), in the last CAN position at the end of the daisy chain.
3. If using an expansion bay to expand the system, remove the terminator and connect the CAN bus cable to the CAN OUT connector of the top rectifier shelf of the expansion bay.

Figure 45: CAN terminator

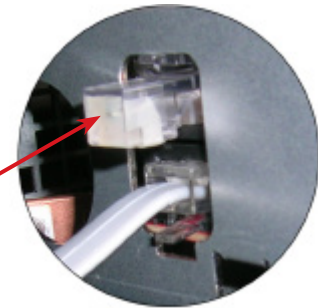

7.6 DC wiring



ATTENTION

Leave cables or busbars disconnected at the battery and verify the output polarity using a voltmeter. Make battery connections only after all other wiring is completed.

DC output wire must be UL approved XHHW or RHH/RHW (for Canadian users, RW90 Type). Control and sense wires must be UL approved Style 1015 (for Canadian users, TEW type).

The common output leg of the rectifier system must be connected to ground, typically at the battery return bus.

7.6.1 External battery bay output connections

Battery cables must be sized for a 0.25 volt drop from the battery to the power system at full load including anticipated growth. The cables must also meet ampacity requirements. Cables terminating directly on the battery posts or connection details must be secured so that there is no stress on the battery posts. Lead plated lugs and lead plated or stainless steel hardware must be used on all terminations at vented batteries to reduce corrosion.

1. Prepare, route, and connect cables from the power system to the battery termination details if battery cables were not pre-wired from the factory.
2. Burnish the terminating points and apply a corrosion-inhibiting agent, such as Sanchem Inc. NO-OX-ID® A-SPECIAL electrical grease, to all battery terminal connections.
3. Do not complete the final live connections to the battery. Leave open and insulate the final connections or remove the battery fuses. Switch off the battery contacts if used.

Refer to the system startup procedure before connecting the batteries online.

7.6.2 Load distribution

Refer to guidelines supplied with the load equipment. Typically, distribution cables are sized to provide a 0.5 volt loop drop at full load and meet the ampacity requirements of the protection fuse or circuit breaker.

7.6.3 Connecting battery temperature probes

1. Locate the battery temperature probes from the Cordex® HP L-ADIO low voltage smart peripheral coiled below the distribution center.
2. Uncoil and connect the temperature probes to a battery termination post negative in each battery tray.

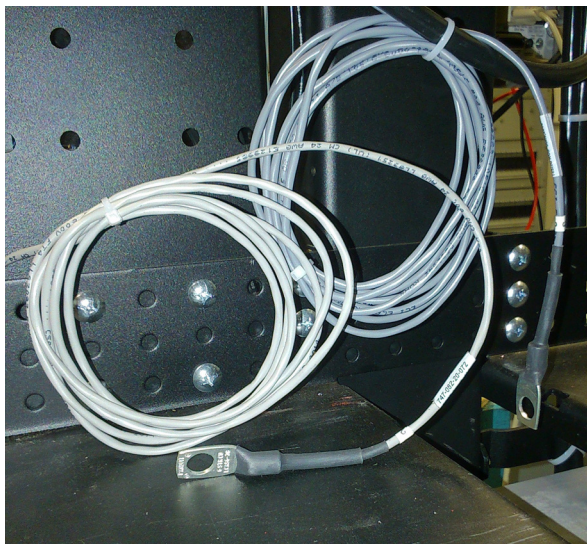

Figure 46: Battery temperature probes



Figure 47: Battery temperature probes, battery bay

7.7 Dual voltage conversion

The staged tier is split into four sections. It is factory configured to supply two voltages: -48VDC on the left section (positions 1 through 12), and $+24\text{VDC}$ on the right three sections (positions 13 to 24). The $+24\text{VDC}$ sections are joined by a link bar (see [Figure 47](#)). This link bar can be relocated to change the number of -48V and $+24\text{V}$ positions available. If $+24\text{VDC}$ is not required, the $+24\text{VDC}$ supply cables can be removed and an extra link bar can be added to turn the entire tier to -48VDC . See the following steps to reconfigure the convertible tier.

1. Turn off or remove the circuit breakers in positions 13 to 16.
2. Loosen the nuts in positions 15 to 18.
3. Remove the link bar that occupies positions 15 to 18.

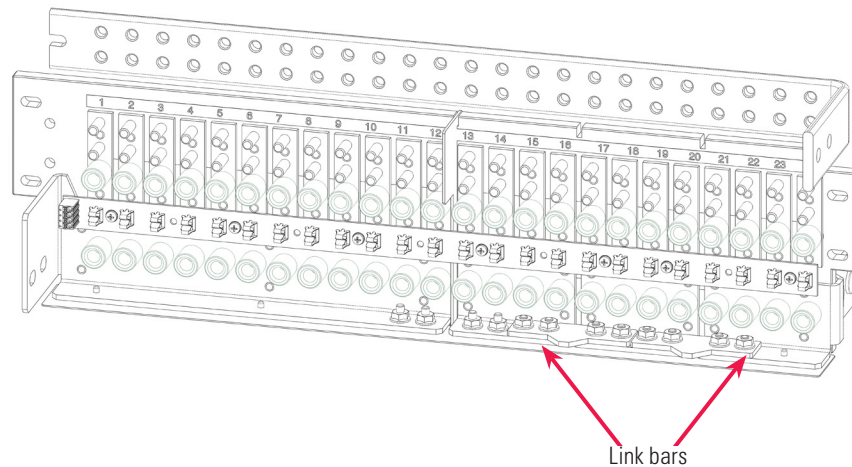

Figure 48: Dual voltage tier, factory configured assembly

4. Tighten the nuts in positions 15 to 18.
5. Loosen the nuts in positions 11 to 14.
6. Remove the voltage divider insulator or marker between positions 12 and 13 and place it between positions 16 and 17.
7. Insert the link bar from step 3 so that it occupies positions 11 to 14.
8. Tighten the nuts onto link bar in positions 11 to 14.
9. Turn on and insert circuit breakers into positions 13 to 16.

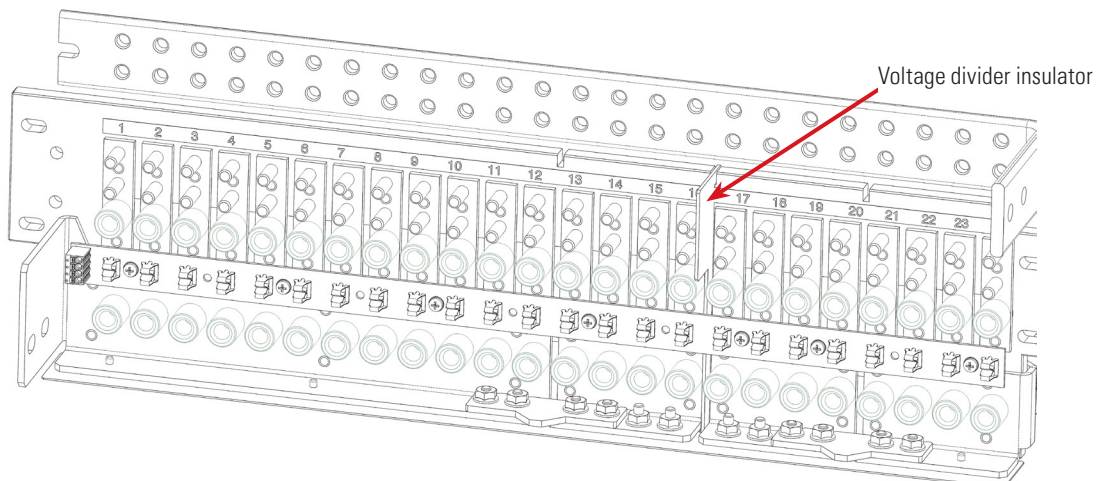

Figure 49: Dual voltage tier converted assembly

7.8 High capacity breaker alarm and shunt wiring

1. Connect the alarm wire (-HOT) from the normally closed (NC) position on the breaker, to one of the available digital inputs on the Cordex® HP L-ADIO smart peripheral.
2. Add a (+ RETURN) jumper from the digital input.
3. Connect the shunt wires black and white to hot (-) and return (+) current input respectively to a nearest Cordex® HP L-ADIO smart peripheral or Cordex® HP 6i-ADIO smart peripheral.

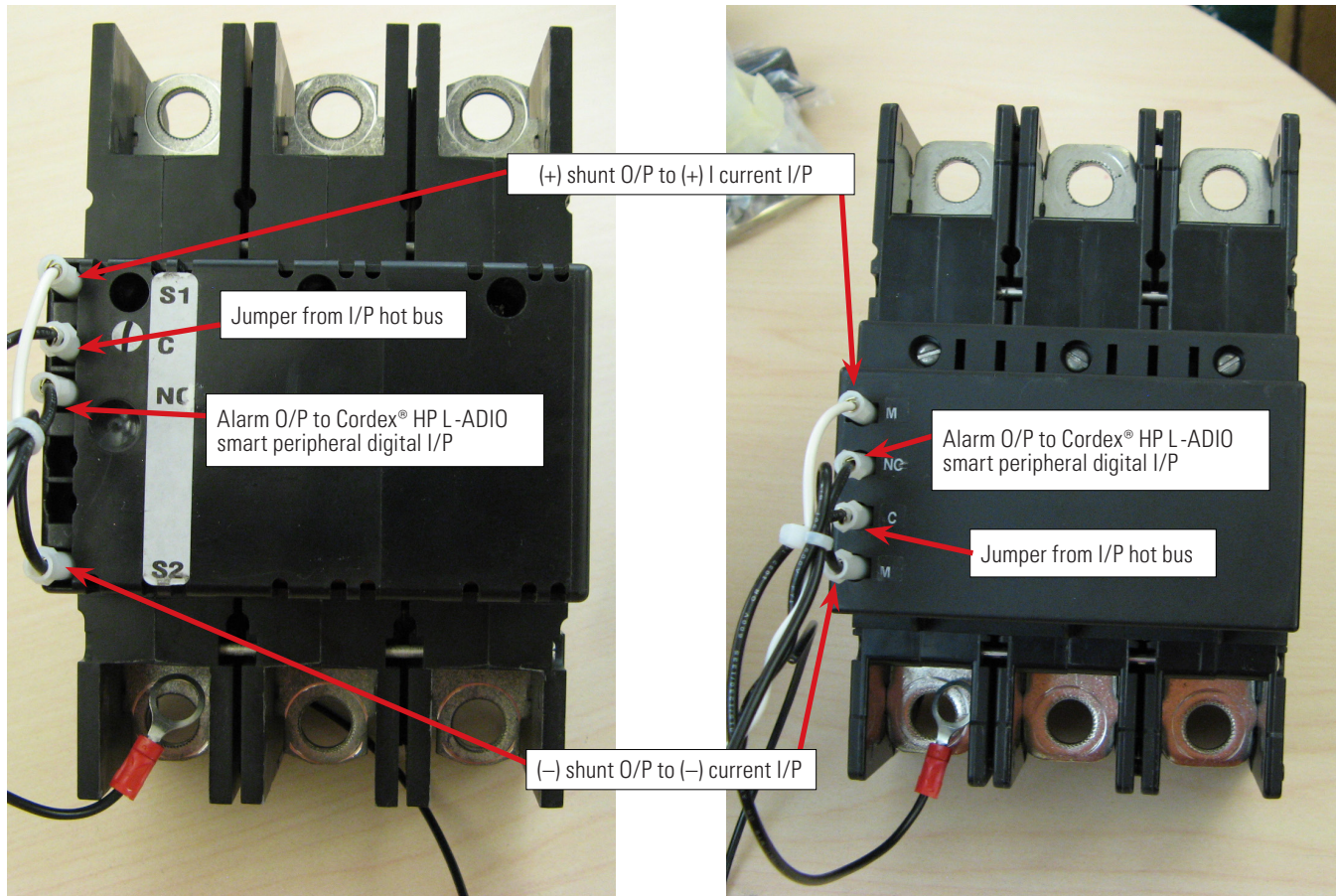

Figure 50: Optional high capacity breaker alarm and shunt wiring

7.9 Signal wiring

1. Use the Form C relay contacts on the Cordex® HP L-ADIO smart peripheral to extend various alarm or control signals to an external site monitor.
2. Use 26 AWG (0.14 mm²) or larger wire.
3. Bundle signal wires together and route through the top hole openings of the distribution chassis using a plastic bushing to protect wiring as needed.

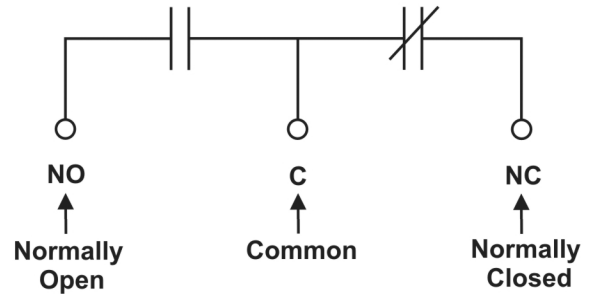

Figure 51: Relay connections, not energized state

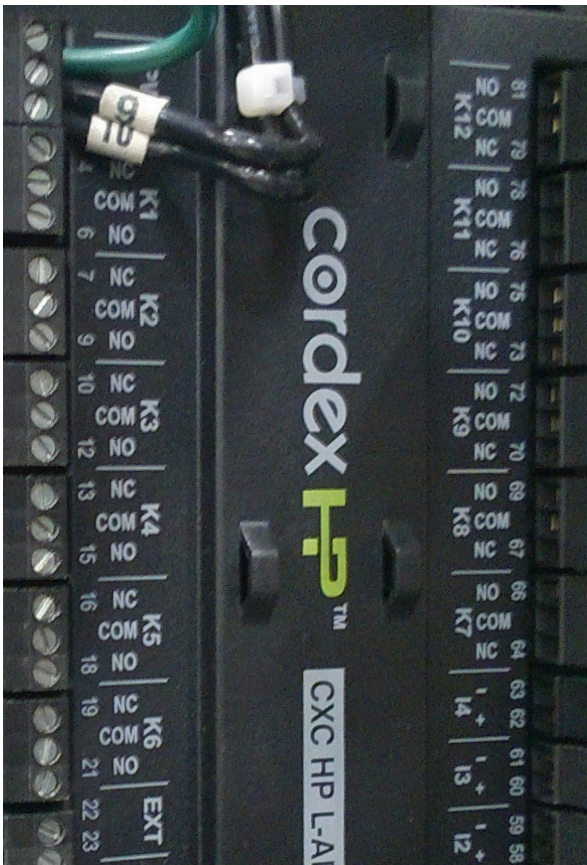

Figure 52: Alarm relay pinouts

Table L: Relay assignments

Channel description	Factory default designation
Relay K1 to K5	LVD or not used
Relay K6 to K8	Not used
Relay K9	AC MAINS HIGH/LOW alarm
Relay K10	SYSTEM MINOR alarm
Relay K11	SYSTEM MAJOR alarm
Relay K12	SYSTEM CRITICAL alarm

7.9.1 Relays

Relays can be programmed to be energized or not energized during an alarm condition. See the system controller software manual for programming. Relays can be reassigned in the **Relays** table. From the system controller's main **Dashboard**, go to **Modules**. In the **CAN Modules** table, select the module and select **Go To**.

For more information refer to the ADIO maintenance section of the system controller software manual.

7.9.2 Analog inputs



WARNING

Ensure that the correct polarity is used for all input cable terminations.

The analog input channels are used to monitor various types of electrical signals. Some of the analog channels are reserved for specific signals, while others are designated as general-purpose inputs, which accommodate various types of analog signals. The input cables should be bundled together and routed through the entry hole openings on the distribution chassis as required.

Default configurations and terminal numbers described below have been summarized in the drawings located at the end of this document.



ATTENTION

To reduce risk of fire, use only 26 AWG (0.14 mm²) or larger wire.

7.9.3 Digital inputs

The digital input channels are used to monitor various alarm and control signals. All input channels are voltage activated and accept a bipolar (negative or positive) DC signal directly.

7.9.4 Connection method

Typical Cordex® systems use the reset with Hot and trigger with Ground (common) connection. The digital input is wired in such a way that Hot is wired directly into one of the input terminals. For example, positive input for +24 volt systems. The other input terminal is wired to the Ground (common) of the system through a dry contact relay usually located on the equipment requiring monitoring. This method (Figure 52) allows the digital input to receive or not receive a Ground signal on an alarm.

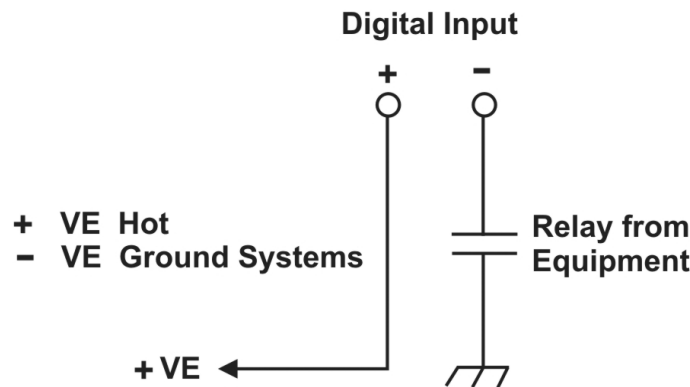

Figure 53: Digital input connection method

7.9.5 Programming the digital input

The digital input channels can be programmed for “active high” or “active low.” Active high indicates “alarm on the presence of a ground signal” and active low indicates “alarm on the removal of a ground signal.” See the system controller software manual for detailed instruction on programming.

Table M: Voltage level definitions for digital inputs		
Voltage range (VDC)	Voltage level (VDC) Considered as “0” (Off)	Voltage level (VDC) Considered as “1” (On)
-60 to +60V (system voltage setting)	-1 to +1V	(-60 to -5V) or (+5 to +60V)

8. System startup

After completing the system installation and power system wiring, perform the following startup and test procedure to ensure proper operation.

1. Visually inspect the installation thoroughly.
2. Verify:
 - AC input power is off.
 - Batteries are disconnected.
 - All circuit breakers are off and no fuses are installed if any loads are connected.
 - All power modules are removed from the shelves.
3. Triple-check the polarity of all connections.
4. Install one rectifier module into the front left-most position using the side of the shelf as a guide.
 - For a Cordex® HP 2.4/3.0kW rectifier module:**
 - Place the rectifier module in the shelf.
 - Lift the handle and slide the module into the rear connector inside the shelf.
 - Apply pressure on the module front panel to engage the rear connector in the shelf receptacle.
 - Flip the handle down to lock the module into place.
 - For a Cordex® HP 4.0/4.6kW rectifier module:**
 - Slide the module into the rear connector inside the shelf.
 - Apply pressure on the module handle to engage the rear connector in the shelf receptacle.
 - Tighten the screw on the bottom of the faceplate to secure the module in the shelf.
5. Verify that the AC input voltage is correct and that the circuit breaker switch for the corresponding feeder circuit breaker is ON. The power module green LED will illuminate after a preset start delay.
6. Test the functionality of various module alarms and controls using the system controller's LCD panel or web interface.
7. Verify the correct battery polarity using a voltmeter. Ensure that no cells or batteries are reversed.
8. Connect the batteries to the output of the system.
9. Install the remaining power modules.
10. Configure the battery parameters according to the battery manufacturers recommendations. See the system controller software manual for detailed instructions on how to configure the batteries.
11. From the **Power System > System Functions > Battery Maintenance > Equalize** menu of the system controller, set the float and equalize voltage to the levels specified by the battery manufacturer.
12. Use the system controller to test the functionality of various module alarms and controls especially the battery circuit breaker alarm test. Verify alarms are transmitted to the site monitor.
13. Perform a load test with the system using a resistive load box.
14. Enable the temperature compensation feature in the **Power System > System Functions > Temperature Compensation** menu. Program the settings for slope and breakpoints (upper and lower) with respect to the specific batteries used.

8.1 Factory ranges and default values

The following table shows the rectifier module settings, ranges, and default values. Changes are made through the system controller interface.

Table N: Rectifier module factory ranges and default values

Setting	Range (minimum to maximum)	Default value
Float (FL) Voltage	47.5 to 58.2V	54V
Equalize (EQ) Voltage	49.8 to 60.2V	55V
Battery Test (BT) Voltage	44 to 52V	46V
Overvoltage Protection (OVP) ¹	63V	63V
Current Limit (CL)	23 to 100%	100%
Power Limit (PL)	0 to 100%	100%
Module Start Delay	0 to 250 s	1 s
System Start Delay	0 to 600 s	0 s
Low Voltage Alarm (LVA)	42 to 52V	44V
High Voltage Alarm (HVA)	52 to 63V	55.5V
EQ Timeout	1 to 2399 h	30 h
BT Timeout	1 to 250 h	8 h
Softstart Ramp-rate	Normal/Fast	Normal
CL/PL Alarm	Enable/Disable	Enable
Remote Shutdown	Enable/Disable	Enable
Ramp Test	Enable/Disable	Enable

¹The overvoltage protection value cannot be set below the present system FL/EQ/BT voltage setting or the safe mode voltage of 51.4V.

9. Maintenance

Although very little maintenance is required with Cordex® systems, routine checks and adjustments are recommended to ensure optimum system performance. Qualified service personnel should perform this work.

The following table lists a few maintenance procedures for this system. These procedures should be performed at least once a year.



WARNING

Use extreme care when working inside the unit while the system is energized. Do not make contact with live components or parts.



ATTENTION

Circuit cards, including semiconductor devices, can be damaged by static electricity. Always wear a grounded wrist strap when handling or installing circuit cards.



ATTENTION

Ensure redundant modules or batteries are used to eliminate the threat of service interruptions while performing maintenance on the system's alarms and control settings.

Table O: Sample maintenance log

Procedure	Date completed
Inspect all system connections. Re-torque if necessary.	
Verify alarm and control settings.	
Verify alarm relay operation.	
Clean ventilation openings of the rectifier modules and converter modules.	

10. Troubleshooting

Shelves and modules are designed for simple installation and reliable, trouble-free operation.

In most cases the modules will recover from minor alarms and faults automatically. However under certain conditions the modules may need remote control. And under very rare cases the module may need a manual reset (remove and reinsert the module). In the unlikely event of a module failure, it may need replacement.

A shelf can accommodate up to four or five modules depending on the model and shelf. The modules have various LED status indicators that provide information about the system.

When the shelf system is used in conjunction with a system controller, detailed system information and status can be easily obtained. Additional information can be obtained via the web interface using the Ethernet port.

The following tables provide a quick reference of the various LEDs and the corresponding states.

10.1 Cordex® HP Rectifier Module LEDs

Table P: Cordex® HP rectifier module LED states

LED name	Color	State	Meaning
Alarm	Red	Off	Indicates no failure or fault in the module.
		Solid	Indicates the output has shutdown to protect property or personnel.
		Flashing	Indicates a communication failure persisting for five minutes. Indicates the locate module command is active.
AC	Green	Off	Indicates output is in an off state.
		Solid	Indicates output is driven.
		Flashing	Indicates the locate module command is active.
DC	Green	Off	Indicates a failure or fault with input.
		Solid	Indicates that input is functioning correctly.
		Flashing	Indicates the locate module command is active.

10.2 Cordex® HP System Controller LEDs

Table Q: Cordex® HP system controller LED states

LED name	Color	State	Meaning
Major/critical alarm (bell icon)	Red	Off	Indicates no active alarms.
		Solid	Indicates one or more major/critical alarms. There can be minor alarms as well.
		Flashing	All LEDs cycle on initial startup.
Minor alarm (caution icon)	Yellow	Off	Indicates no active alarms
		Solid	Indicates one or more minor alarms.
		Flashing	All LEDs cycle on initial startup.

OK (OK icon)	Green	Off	N/A
		Solid	Indicates that there are no alarms.
		Flashing	All LEDs cycle on initial startup.

10.3 Cordex® HP L-ADIO Low Voltage Smart Peripheral LEDs

Table R: Cordex® HP L-ADIO low voltage smart peripheral LED states

LED name	Color	State	Meaning
LVD	Yellow	Off	Indicates the LVD override feature is disabled.
		Solid	Indicates the LVD override button has been selected and the feature is enabled.
		Flashing	N/A
Power	Blue	Off	Indicates no power to the device.
		Solid	Indicates power is present.
		Flashing	N/A
COMMS	Green	Off	Indicates no communication with the system controller.
		Solid	Indicates the peripheral has been acquired by the system controller.
		Flashing	The LED flashes in response to a module locate command from the system controller.

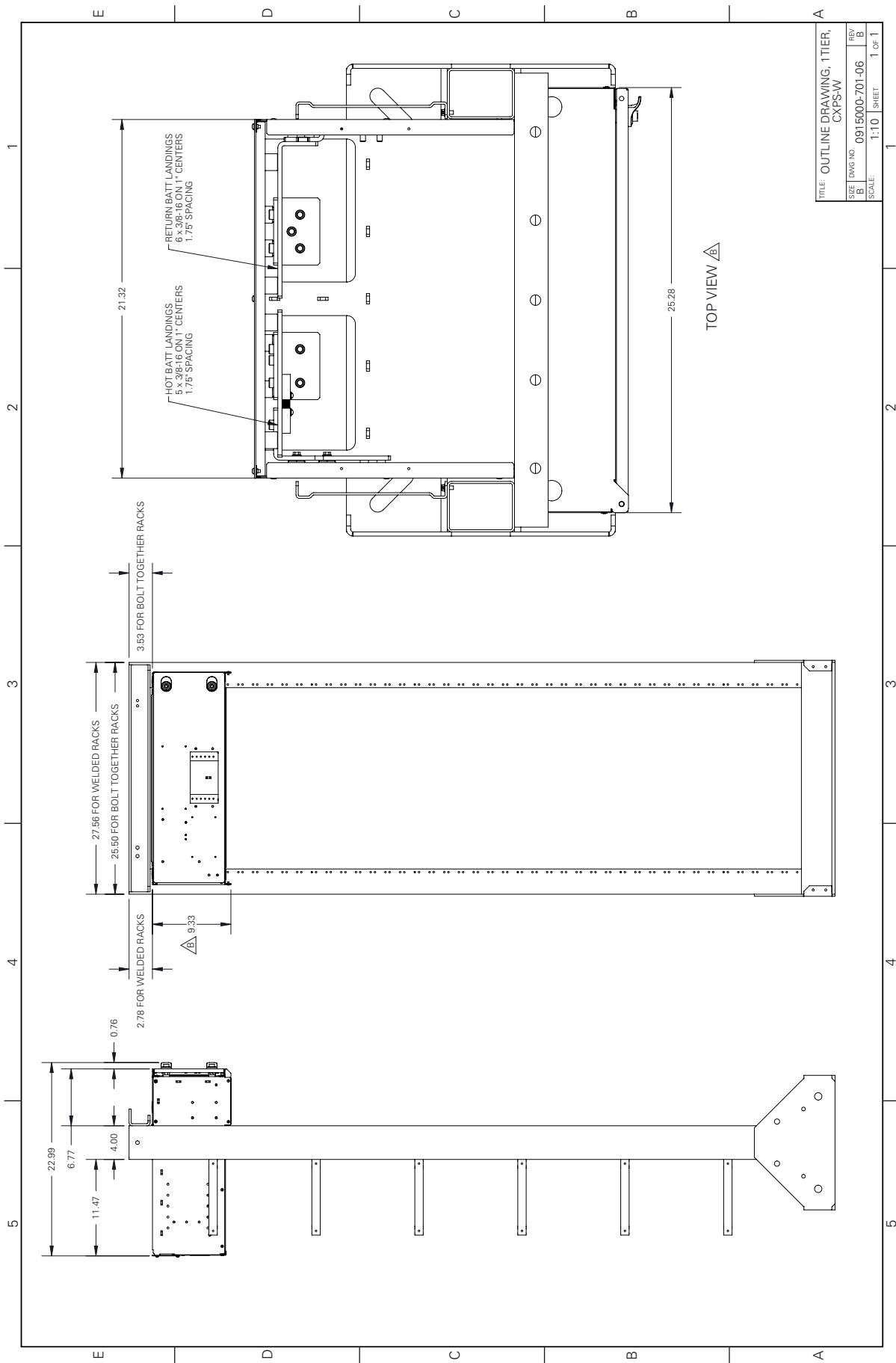

TITLE: OUTLINE DRAWING, 1TIER, CXPS-W	
SIZE: B	DWG NO.: 0915000-701-06
SCALE: 1:10	SHEET: 1 OF 1

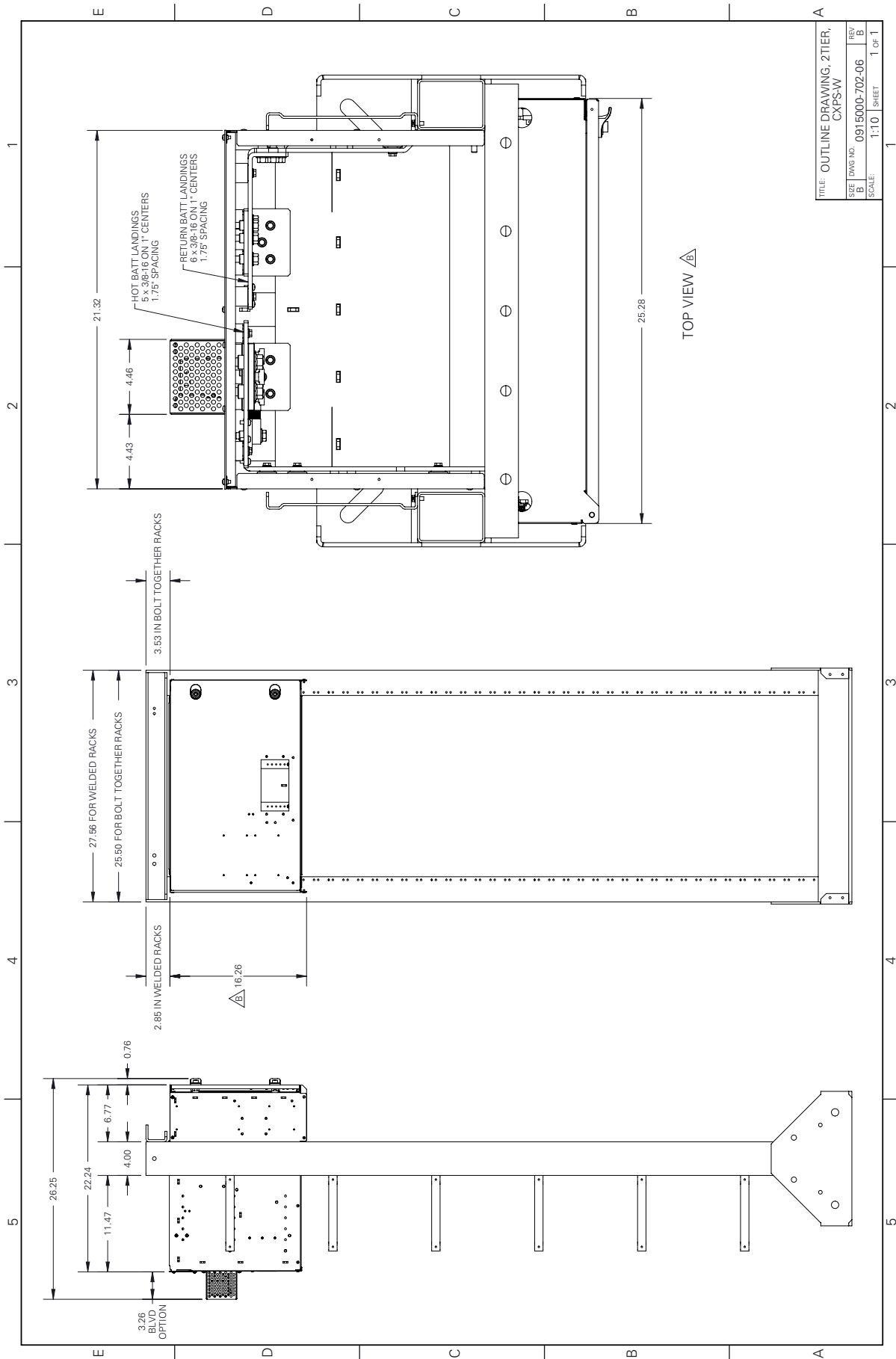

TITLE: OUTLINE DRAWING, 2TIER, CXPS-W		REV: B	1 OF 1
SIZE: B	DWG NO: 0915000-702-06	SCALE: 1:10	SHEET: 1

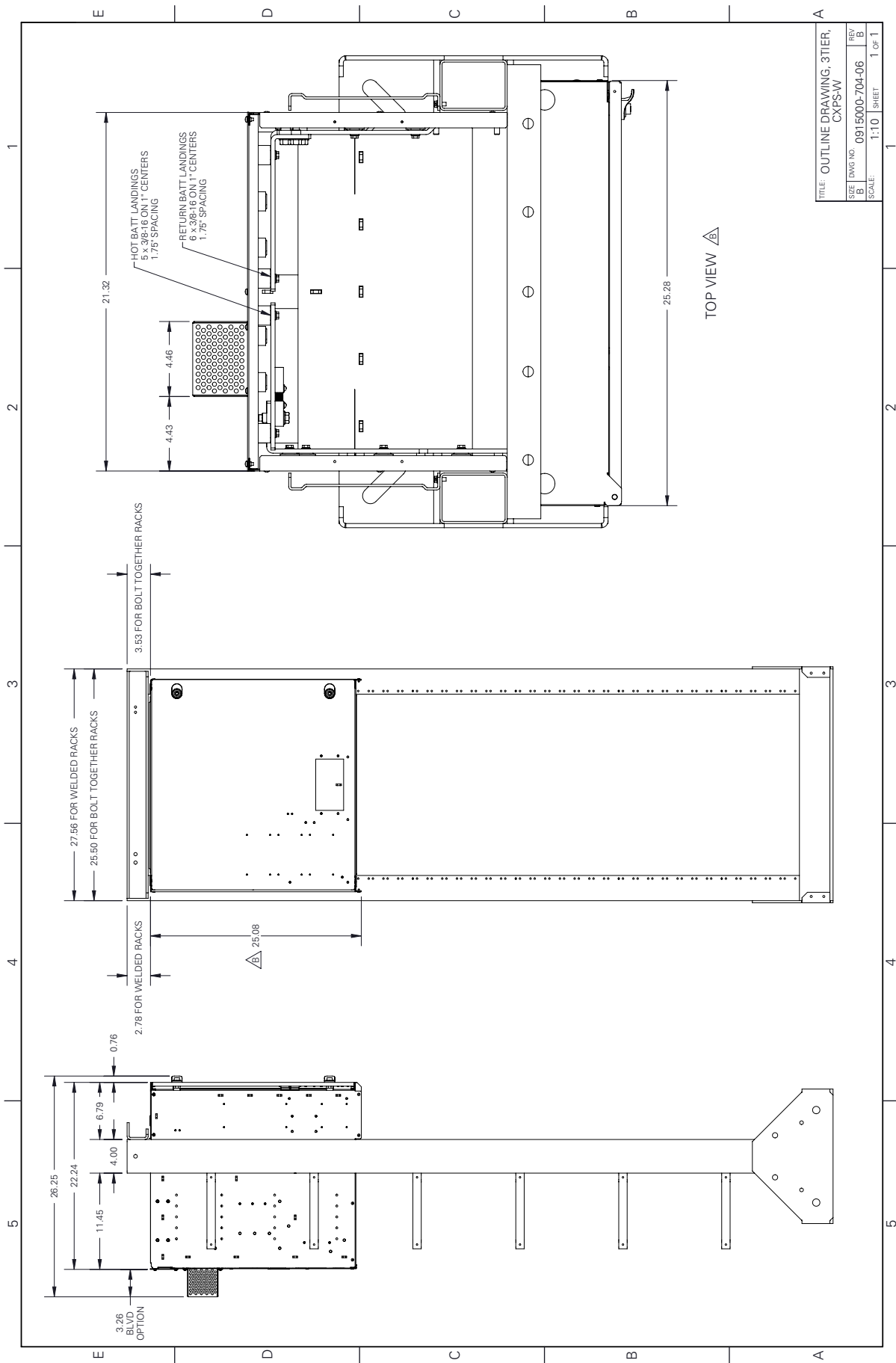

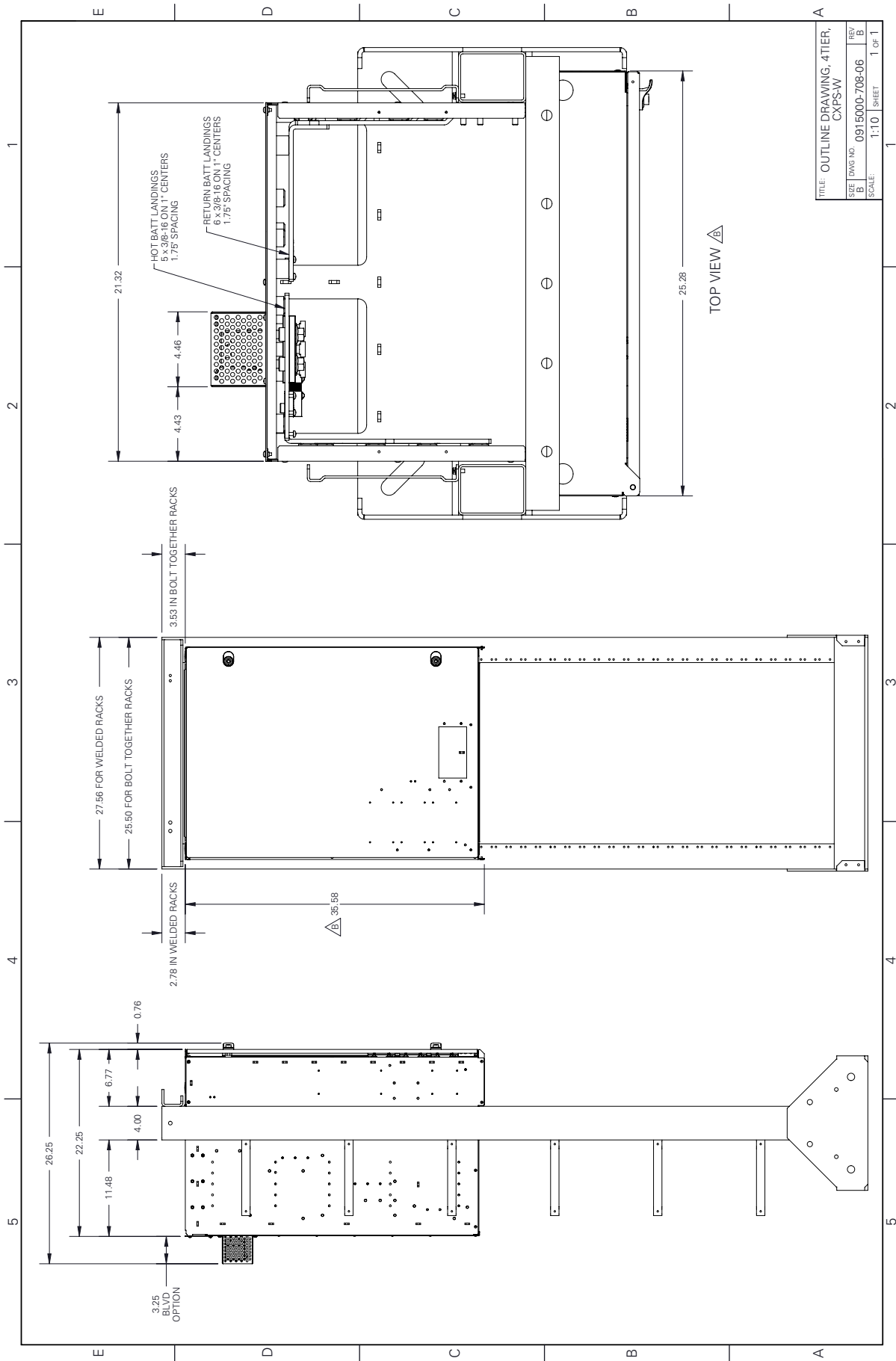

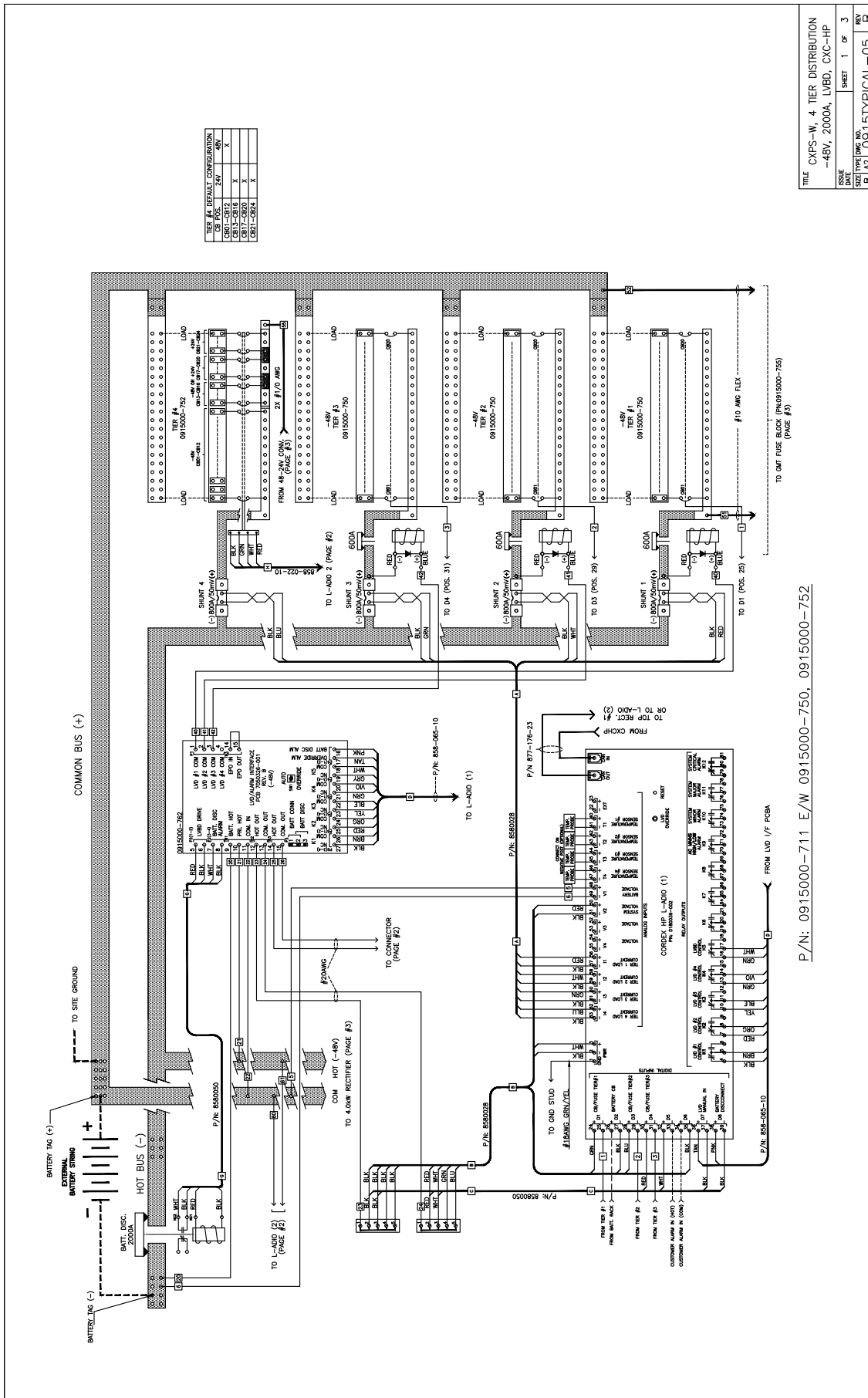

TITLE CXPS-W, 4 TIER DISTRIBUTION
-48V, 2000A, LVBD, CYC-HP
ISSUE SHEET 1 OF 3
SIZE TYPE DWG. NO. 0915TYPICAL-05
B A2 B

P/N: 0915000-711 E/W 0915000-750, 0915000-752

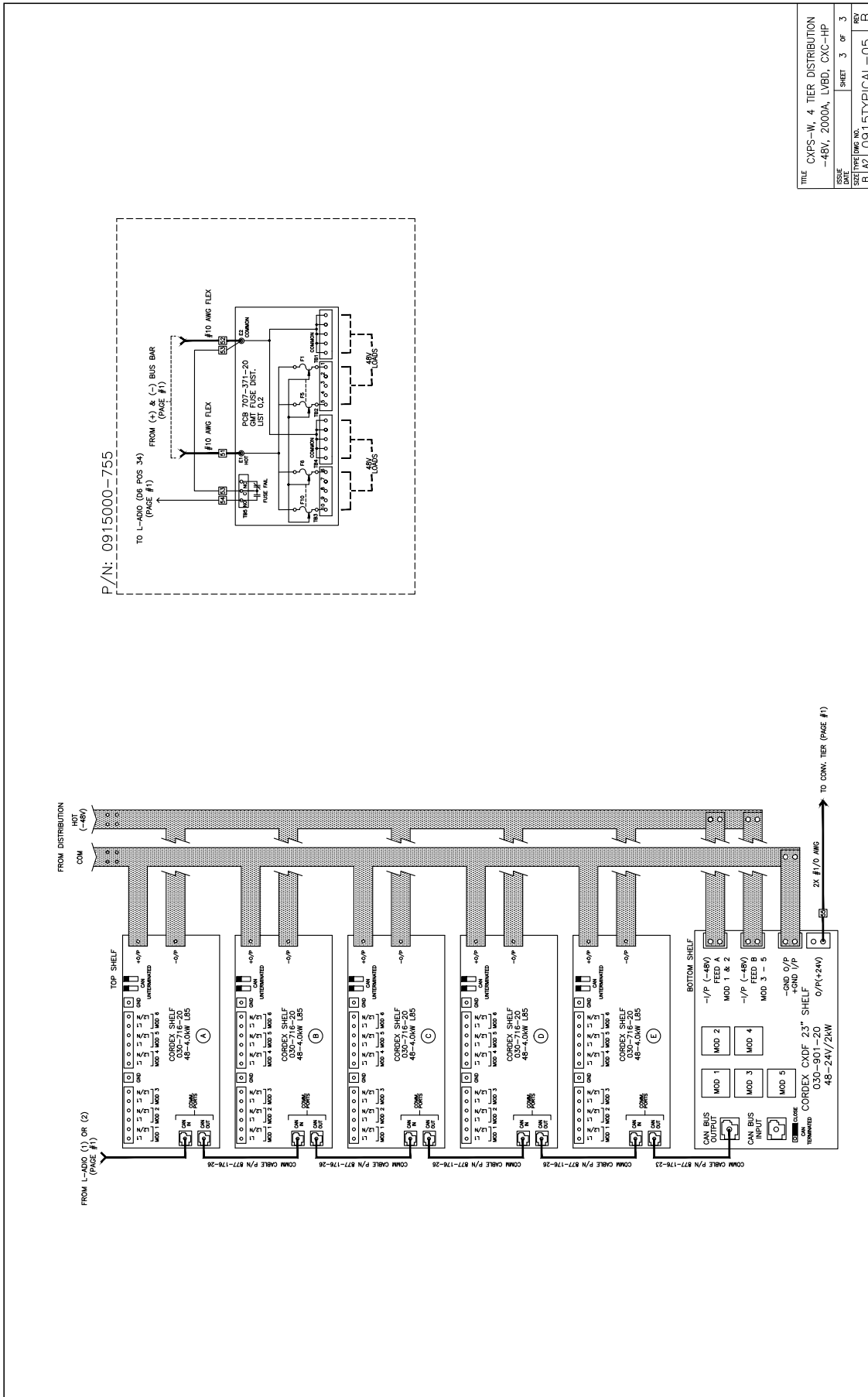

P/N: 0915000-755

TITLE	CXPS-W, 4 TIER DISTRIBUTION	SHEET	3	OF	3
ISSUE	-48V, 2000A, LVBD, CXC-HP	SIZE	TYPE	DATE	REV
B	A2	091515TYPICAL-05			B



Alpha Technologies Ltd. | 7700 Riverfront Gate, Burnaby, BC V5J 5M4 Canada
Toll Free North America: +1 800-667-8743 | Outside North America +1 604-436-5547 | Technical Support +1 888-462-7487
For more information visit our website at: www.enersys.com

© 2025 Alpha Technologies Ltd., an EnerSys company. All Rights Reserved. Trademarks and logos are the property of Alpha Technologies Ltd. and its affiliates except for CEC®, CSA®, IEC®, NEC®, OSHA®, National Electrical Code®, UL®, NO-OX-ID®, Kydex®, and Scotch-Brite®, which are not the property of EnerSys. Subject to revisions without prior notice. E. & O.E.